

A HISTORY OF AQUARIUM INVENTIONS

The First 100 Years

By Albert J. Klee

Combination
Aquarium, Elevator
and Fountain: 1880

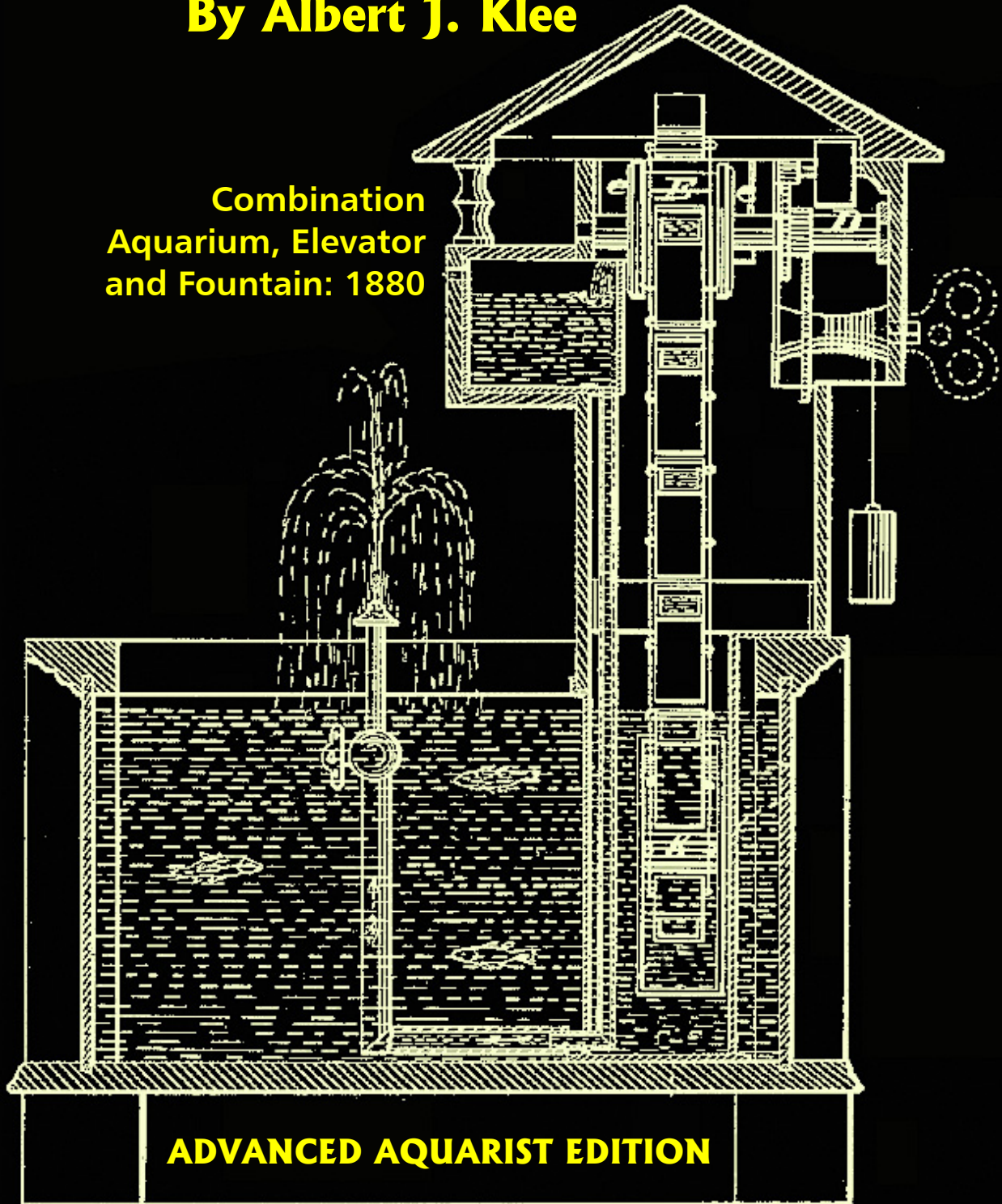

ADVANCED AQUARIST EDITION

Dedicated to those unsung innovators whose names are forgotten but whose spirit of imagination lives with us in the advancement of the aquarium hobby.



James Ambrose Cutting, (1814-1867), who in 1861 was awarded the fourth U.S. aquarium patent.

Copyright@ 2007 and 2018 by Albert J. Klee. Layout and cover design by Albert J. Klee. All rights reserved under International and Pan-American Copyright Conventions. Except for brief quotes used as part of a review, no part of this publication may be reproduced, stored in a retrieval system, or transmitted in any form or by any means, electronic, mechanical, photocopying, recording, or otherwise, without the prior written permission of the copyright owner.

AJK Publications
Milford, Ohio

“Go little book and since there is much great diversity in English and our writing is so young, I pray to God that none may mangle thee, or wrench thy metre by default of tongue; and wheresoever thou be read, I beg of God that thou be understood!”

Geoffrey Chaucer, *Troilus and Criseyde*

A HISTORY OF AQUARIUM INVENTIONS – THE FIRST 100 YEARS, 1858-1958

By Albert J. Klee, Ph.D.

This history of aquarium inventions fills a gap in our knowledge of the early aquarium scene in this country by providing a look into the development of aquarium equipment. Our knowledge about the hobby in the 1800's, for example, is limited because this period predates aquarium societies, aquarium periodicals, and even most aquarium books. The periodical literature of the day – and much can be said of the books, as well - was sparse with regard to aquarium hardware and when it did occur, dealt mainly with starting an aquarium, not with the details of what was available at the time and certainly not with the personalities of the day. Without this history of invention we would not know, for example, about George Gunther of New York City, a prolific creator of items for the hobby who was clever and innovative, some of whose ideas were far ahead of their time.

Unfortunately, we do not know the fate of these inventions during their lifetime, whether they were actually manufactured and sold, and if so, if they met with commercial success. Equipment improves or is replaced over time. An invention may have been successful in its day but like most commodities, it becomes obsolete and is forgotten. It is not reasonable, therefore, to scoff at something that may have been useful in the past merely because we fail to place it in perspective today.

This venture has afforded me much pleasure – a smile here or there at the more fanciful of these patents and a fascination with the imagination reflected in others. I hope the reader will enjoy learning about them as much as I did.

HOW TO NAVIGATE THROUGH THIS BOOK

I started this venture quite by accident after discovering an early patent on an automatic fish feeding device. This started me thinking about other hobby inventions and ultimately led to a systematic search of U.S. Patent Office documents that pertained to the

aquarium hobby. Most utility patents are accompanied by a great deal of descriptive material and so at the beginning of each patent I have distilled each of them into a brief paragraph and, at times, even a single sentence. This is usually followed by my own evaluation of the worth of the patent. For those who desire more detail, I also supply the inventor's complete description.

To assist those who may wish to examine these patents in greater detail and to make the text for each patent easier to find, each patent entry starts with its Figure number, the inventors name for the patent and

CONTENTS	
INTRODUCTION.....	2
THE EARLY YEARS:	
THE DECADE OF 1858-1868.....	6
POST CIVIL WAR:	
THE DECADE OF 1869-1878.....	11
EDISON INVENTS THE ELECTRIC LIGHT BULB:	
THE DECADE OF 1879-1888.....	16
THE WESTERN INDIAN WARS COME TO AN END:	
THE DECADE OF 1889-1898.....	22
THE PRESIDENCY OF THEODORE ROOSEVELT:	
THE DECADE OF 1899-1908.....	33
WORLD WAR I:	
THE DECADE OF 1909-1918.....	45
PROHIBITION:	
THE DECADE OF 1919-1928.....	56
THE GREAT DEPRESSION:	
THE DECADE OF 1929-1938.....	77
WORLD WAR II:	
THE DECADE OF 1939-1948.....	120
THE HOBBY IN HIGH GEAR ONCE AGAIN: THE DECADE OF 1949-1958.....	133
CONCLUSION.....	202
INDEX.....	203

the patent number, all in square brackets and bold-faced; for example, [Figure 192, *Aquarium Heating*, Number 2805313].

This Advanced Aquarist Edition is much longer than the first. For one thing, it contains all the original figures in each patent, not just those that get the idea across. It also contains a brief explanation of each figure in every patent. In general, readers can easily understand how the patent works just by reading my explanations and referring to the figures. However, unlike Design patents (both will be described shortly) Utility patents are usually complicated and many cannot be understood just by examining the figures in the patent. Therefore, this edition provides the text of most Utility Patents and for those who are more interested in the details of some more complicated patents, they can read my rewrite of the text of the patent that follows my remarks and evaluations.

INTRODUCTION

“The lunatic, the lovers, and the poet, are of imagination all compact,” Shakespeare tells us in *A Midsummer Night’s Dream*. To this we might add one more to the list, the innovative aquarist. In the aquarium world the next best thing to sliced bread is an idea that takes the aquarium world by storm. The aquarium hobby had its start in this country shortly before the issuance of the first aquarium patent was granted. This book examines all of the patents awarded by the United States Patent Office between 1858 and 1958 that described concepts for tanks, accessories and gadgets. Some were well thought out and useful for their time, others formed the basis for articles used in today’s hobby, and some that if actually manufactured wouldn’t have worked or else were just plain silly.

One ought to keep in mind that the development of an aquarium device did not necessarily start from scratch. In fact, many of these had their inception in a piece of equipment originally developed for other applications and later modified for use in the aquarium. The forerunners of aquarium filters, for example, frequently were purifiers for drinking water, and the antecedents of aquarium heaters often were de-

vices built for boilers. One patent for an aquarium heater actually had its origin in a foot warmer!

One might reasonably expect that the inventors whose work we shall describe lived mainly in those cities noted for their early aquarium activity, such as New York City, Chicago, and Philadelphia, and, of the 231 patents described in this book, 31 are from New York City, 17 from Chicago, 17 from Philadelphia, and 10 from Brooklyn. Since Brooklyn became part of New York City in 1898, New York City with its grand total of 41 is clearly the winner over the period covered by this book. Although these cities make up almost one third of the patents, the hometowns of some of the others seem highly unlikely places to find innovators of the aquarium world.

THE TWO TYPES OF PATENTS

United States patents (the term “patent” originates from the Latin word *patere* which means “to lay open,” i.e. make available for public inspection) relevant to the aquarium hobby are of two types:

(1) **Utility Patents.** These are issued for the invention of a new and useful process, machine, manufacture or composition of matter, or a new and useful improvement. It generally permits its owner to exclude others from making, using, or selling the invention for a period of up to twenty years from the date of patent application filing (for some of the earlier patents discussed in this book the period was only 14 years), subject to the payment of maintenance fees. The utility patents described in this book average about 4 pages, and both the text and the drawings are usually presented in quite a bit of detail.

(2) **Design Patents.** Of the 231 patents described here, 82 are design patents, identified by the letter “D” preceding the number. These are issued for a new, original or ornamental design for an article of manufacture. They permit its owner to exclude others from making, using, or selling the design for a period of fourteen years from the date of patent grant, and are not subject to the payment of maintenance fees. In the context of this book they generally

describe some sort of decorative aquarium (but not always) and typically consist of two pages, one containing a drawing of the design and the other a description that is not a description at all. This use of the term “description” with respect to design patents is very misleading since, in effect, all that it really says is, “the drawing is the patent.” On occasion this is not enough to determine what the invention is or what it is designed to do. A case in point is the design patent assigned to Louis Feldman of New York City in 1951 and shown in Figure 1. The name of the patent is “Aquarium Unit,” and the description reads, “...a new, original and ornamental Design for an Aquarium Unit...” However, what is this invention? Is it an aquarium? If so, where are the fish housed and what are the holes for? Or is it simply something to be inserted into an aquarium as an ornament? By sheer chance I discovered that it was a device used for collecting sediment in an aquarium (see Figure 177 on page 133)!

UTILITY PATENTS IN DETAIL

Utility patents typical have four sections: (1) An introduction where the inventor explains what the patent is intended to accomplish, (2) A list of all the figures in the patent with a brief description of what they portray, (3) The main body of the patent where the inventor describes in detail the construction and operation of the invention, and (4) A detailed list of the claims made by the inventor for the patent. Only the first three are of any interest to aquarists since in any utility patent there are things that are described that are original with the inventor and things that are not. If an inventor did not make a list of specific claims, a patent could be voided on the basis that it included things already known and used in practice.

TABLE I			
Number of Patents per Decade			
1858-1868	6	1909-1918	16
1869-1878	6	1919-1928	31
1879-1888	6	1929-1938	74
1889-1898	10	1939-1948	13
1899-1908	13	1949-1958	56

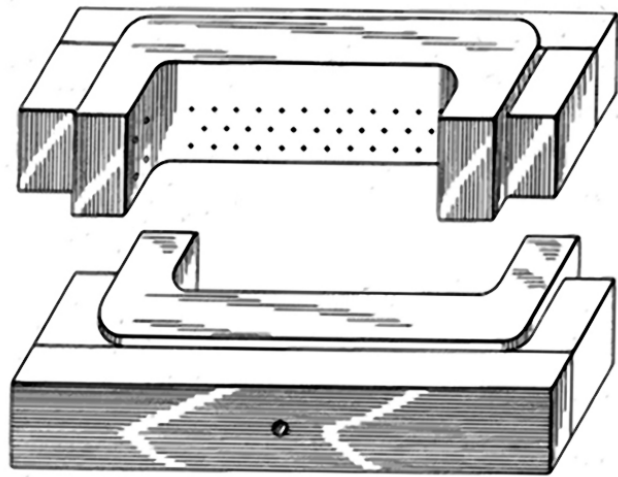

Figure 1. Described in the 1951 Design Patent as an “Aquarium Unit,” but what is it really?

Utility patents are legal documents and thus item (3) where construction and operation are discussed is rife with “legalese” language and often difficult to understand.

The biggest problem, however, is with run-on sentences. A run-on sentence occurs when two or more independent clauses are not joined correctly. There are two types: **fused sentences** and **comma splices**. A **fused sentence** occurs when independent clauses run together with no marks of punctuation or coordinating conjunctions to separate them. An example: *My professor read my paper she said it was excellent.* A **comma splice** occurs when two or more independent clauses are joined only by a comma. An example: *My cat meowed angrily, I knew she wanted food.* The latter is especially prevalent in utility patents and their sentences sometimes have so many independent clauses and commas that independent clauses near the beginning of the sentence are lost to the reader.

Another problem is in the identification of items in a figure. These are usually indicated by a number (**10**), a letter (**B**), a combination of both (**10a**) or a combination of both plus one of more apostrophes (**10b'** or **10b''**). These may or may not be in bold face or italics but bold face is fairly common so I use it to make it easier to refer to something in a figure. All this is well and good but patent writers go overboard

with these devices and consequently clutter up their text and make it tedious to follow. An example: ***10** refers to an aquarium; the aquarium **10** has a cover...* The second **10** here is not needed; it has already been defined and just annoys the reader.

A third problem is needless legalese, such as using the word “said” throughout the description. Example: *The aquarium was placed on a stand, the **said** stand being made of metal.* Sometimes the problem is the use of words not immediately comfortable in meaning to the average aquarist. Example: *The lamp was **disposed** on a table.* The word is used correctly here but most aquarists would expect other words, such as *The lamp was placed on a table.* Other problems are words that are common only in a patent attorney’s lexicon, such as frustoconical and frustopyramidal, meaning truncated cone and truncated pyramid, respectively. The terms and their meanings in Table I may prove helpful in deciphering the arcane language of patent claims:

In this edition I always include all the figures displayed in the patent, and in the text I usually include the list of all the figures in the patent with a brief description of what they portray (unless there are one or two figures that are self-explanatory) and the main body of the patent where the inventor describes in detail the construction and operation of the invention. However, if the accompanying diagrams are sufficient to explain the invention for aquarists, the main body is not included in the entry for that patent. If the text of a patent is lengthy because of detail descriptions of construction (for example, see Figure 191 where the explanatory text consists mainly of descriptions of electrical connections among wires; in this case I decided that the figures and their descriptions were enough to get an idea of the invention) and if the patent is not particularly noteworthy (read “Rube Goldberg”) I either omit it in its entirety or else just provide the inventor’s statement of what the patent was intended to accomplish.

When I edit the text of a patent it is with the aim of simplification and clarity. A quick way for readers to examine the contents of a patent themselves is to use Google Patents (<https://patents.google.com>). Enter

the patent name by preceding it with the letters “US” such as US1620006 and USD76252.

THE PATENT YEARS THAT ARE EXAMINED

This book covers the years from 1858, the date of issuance of the first U.S. aquarium-related patent, to 1958, a period of 100 years (this is actually 101 years but the rounded appearance of 1858-1958 on the title page seemed to me better proportioned than 1858-1957). It spans the period of three major conflicts: the Civil War, World War I and World War II. This also includes the start of the Industrial Revolution in this country to its post-World War II dominance throughout the world. Table II shows the number of aquarium patents issued in each decade of the period covered here. The first three decades started slowly and then accelerated in the next three. During the 1919-1928 decade the number of patents tripled, but it was the depression decade of 1929-1938 that witnessed a tremendous rise in the number of aquarium-related patents granted. The number understandably fell dramatically during the decade containing World War II, but the last decade discussed in this book showed that the patent activity after World War II underwent a rapid recovery.

In the period discussed in this book, an average of 2.3 aquarium-related patents per year was issued; in the period 1974 to 2003, the average was 88 patents per year. The curious who wish to take up where this book leaves off will have to examine almost 3000 patents, a task I do not envy!

Lastly, in an age before standardized spelling, Shakespeare often wrote a word several times in a different way. In a similar vein, the reader is alerted that the place names in this book are those specified in the patents and may no longer be spelled the same today, e.g., Mont Clair (New Jersey) instead of the present-day Montclair, and Leipsic (Germany) instead of Leipzig.

TABLE I: COMMON TERMS USED IN PATENTS

comprised (used to mean consist of or made up of) “The aquarium comprised a tank having a front wall panel, a side wall panel, a rear wall panel and a side wall panel.”

contiguous (used to indicate elements are touching) “Each slide-preventing stop has an upper end surface that is contiguous to one side edge of the upper end surface.”

device for (interpreted as “means for”) “It is a device for use in blood vessels and tracts in the body.”

disposed (used to indicate a part is positioned in a particular place) “A snap-action spring member is disposed in a cut portion formed in the outer lid.”

further including (used in dependent claims to add additional parts) “... said lid unit further including a generally L-shaped spring member.”

heretofore (used to refer back to something previously recited) “There have heretofore been strong user demands that such an indication should be provided on the top of the lid.”

indicium (singular for indices; used to recite something that a human can recognize, such as a mark or a sound) “... so as to provide a field gradient operative to provide an indicium of the linear position of the shuttle.”

means for (used to claim something broadly in terms of its function, rather than specific hardware) “It is an additional object of the invention to provide a compact means for pumping a medicament.”

member (used to refer to a mechanical part when no other word is available) “... attached at one end to a drive member and at the other end to a fixed point on the base of the pump.”

pivotably (used to indicate that a part is mounted and rotatable) “The blade is pivotably carried at one of its ends around a support shaft.” *

plurality (used to introduce more than one of an element) “... a ROM memory having a plurality of reference potential transmission lines.”

providing (used to recite a part in a method claim) “Oxide-nitride-oxide layers are formed above the channel area and between the bit lines for providing isolation between overlying polysilicon word lines.”

said (used to refer to a previously recited part by exactly the same word) “... said memory cell having a first region and a second region with a channel there between and having a gate above said channel.”

slidably (used to indicate that two parts slide with respect to each other) “The charging roller bearing is slidably fitted in a guide groove.” *

so that (used to restrict a part to a defined function) “The cup holders are usually provided with annular grooves or vertical flutes so that the holder is only in contact with the cup.”

substantially (used to fudge a specific recitation) “The side plate which has the hole is also provided with a toner filling opening substantially shaped like a right triangle.”

such that (used to restrict a part to a defined function) “These grooves or flutes provide a structural integrity to the cup holders such that they must be packaged in substantially the same form as they will be used.”

thereby (used to specify a result or connection between an element and what it does) “Said sleeping bag is supported by said carrying straps and carried thereby on one’s back.”

thereof (used as a pronoun to avoid repeating a part name) “Said back wall each being padded and being of equal width, being joined at the sides and the bottom thereof.”

urging (used to indicate that force is exacted upon a part) “By pressing the rod against the urging of the spring, the link members straighten out.”

whereby (used to introduce a function or result at the end of a claim) “Whereby the handle portion attaches to the handle of the device by the securing mechanisms.”

wherein (used in a dependent claim to recite an element (part) more specifically) “A portable printing device as claimed in claim 13, wherein the shutter member includes ...”

* **Note:** There are many other words that use this adjectival form in patents. Example: “Formed at the center of the bottom member was a depression that was threaded and removably seated therein...” For the most part, I have kept them in the descriptions rather than re-writing them.



THE EARLY YEARS: THE DECADE OF 1858-1868

[Figure 2, *Improvement in the Construction of Aquaria*, Number 21719] The earliest American patent was awarded in 1858 to John Chilcott and James Scrimgeour of Brooklyn, New York for a method of making a water-tight seal in the vertical joints in an aquarium.

Figure 1 is an elevation of the corner portion of one end of an aquarium so constructed. Fig. 2 is a top or bird's-eye view of the same. Fig. 3 is a vertical diagonal section through the corner of the said aquarium at the line 1 - 2 of Fig. 2. Fig. 4 is a horizontal section of the same at the line 3 - 4 of Fig. 3. Fig. 5 is a vertical section through the corner portion at the line 5 - 6 of Fig. 2.

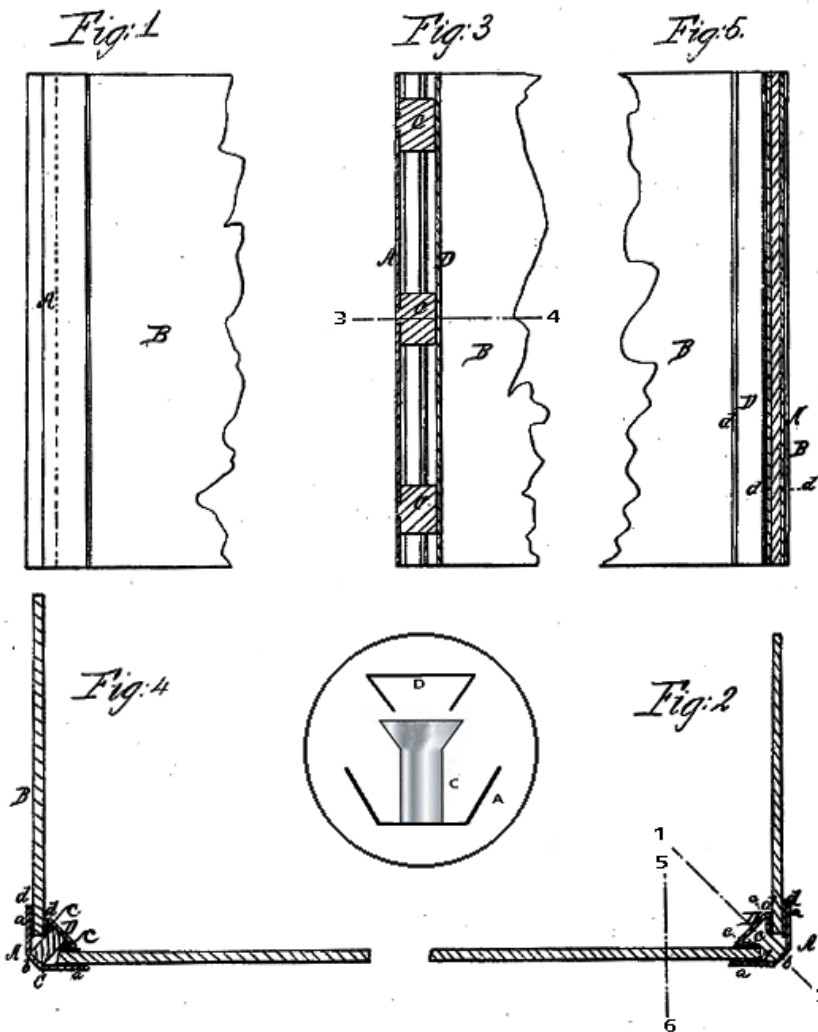

Figure 2: J. Chilcott and Jas. Scrimgeour's aquarium construction design, 1858.

The metal plates A, forming the exteriors of the corners of the aquarium, had metallic dovetailed tenons set at equal distances apart and secured with "rivets or other suitable means." These tenons were slid into a plate D. The drawings are not quite clear so in the circle I have shown a cross section of the tenon, plate A and plate D.

The invention consisted in confining the ends of the side glass plates of the aquarium between the angular marginal surfaces of annular metallic plates (A and D in the figures), between which and the glass plates flat strips of India-rubber ("or other elastic or yielding packing material") were placed. The angular plates and ends of the glass plates were arranged in relation to each other as to form a well or space between them for the reception of cement ("wax and rosin or other suitable material"), which was poured in a heated and liquid state and allowed to cool and solidify, thus producing a water-tight joint at the corners of the aquarium. The bottom of the glass cage was placed into a

grooved board (“wooden or metal”) into which the heated cement could be poured, thus sealing the bottom of the tank. As was typical of the aquaria of the time, there was no top frame. Although this is an effective way to seal the vertical joints, the major weakness was in the strength of the seal between the glass cage and the base. However, the cost of machining the tenons and fastening them to Plates **A** would be high. The tenons would have to be identical in length since Plates **B** would have to be slid down over them. The inventors supplied no information as to how the components were assembled. It would have been difficult, for example, to keep the packing on the glass in place when inserting it in Plates **A** and **B**.

[**Figure 3, Improvement in Aquaria, Number 22019**] Also awarded in the same year, this time to another Brooklyn inventor, Elijah D. Davis, was quite different as it was designed to make an aquarium seem larger than it actually was.

Figure 1 is a transverse vertical section, and Fig. 2 is a front elevation. **A** is the bottom, **B** the ends and **C** the front plate of the aquarium, all constructed in the ordinary manner, except that the breadth of the aquarium is less than usual. **D** is a plate of ordinary silvered glass. **E** is a sheet of any suitable material to protect the silvering and increase the strength of the back. The back **E/D** is much higher than the front **C**.

For ornamental effect Davis gave a curved or wavy outline to the upper edges both of **D** and **C**, but the general proportions adopted were about as follows: Length of aquarium, two feet; height of ends **B**, seventeen inches; height of front **C**, fourteen inches; height of back **D**, twenty inches. These dimensions allowed the effect of the invention to be very finely produced. To the eye of the spectator located in any plane between about forty and fifty degrees inclination above the center of the aquarium, more than one reflected image appeared of the objects in the water. Thus the breadth of the aquarium would appear to be increased to three or four times its actual size. The rays of light strike from an object within the aquarium to the eye of a spectator about forty-five degrees above in the manner shown by the dashed lines, **m n o p**. In the line **m** the fish **F** is seen directly. In the line **n** its image is seen reflected from **D**. In the line **o** is seen its image twice reflected, first by the front **G** and next by the back **D**. In the line **p** is seen its image three times reflected, first by **D**, then by **C**, and finally again by **D**,

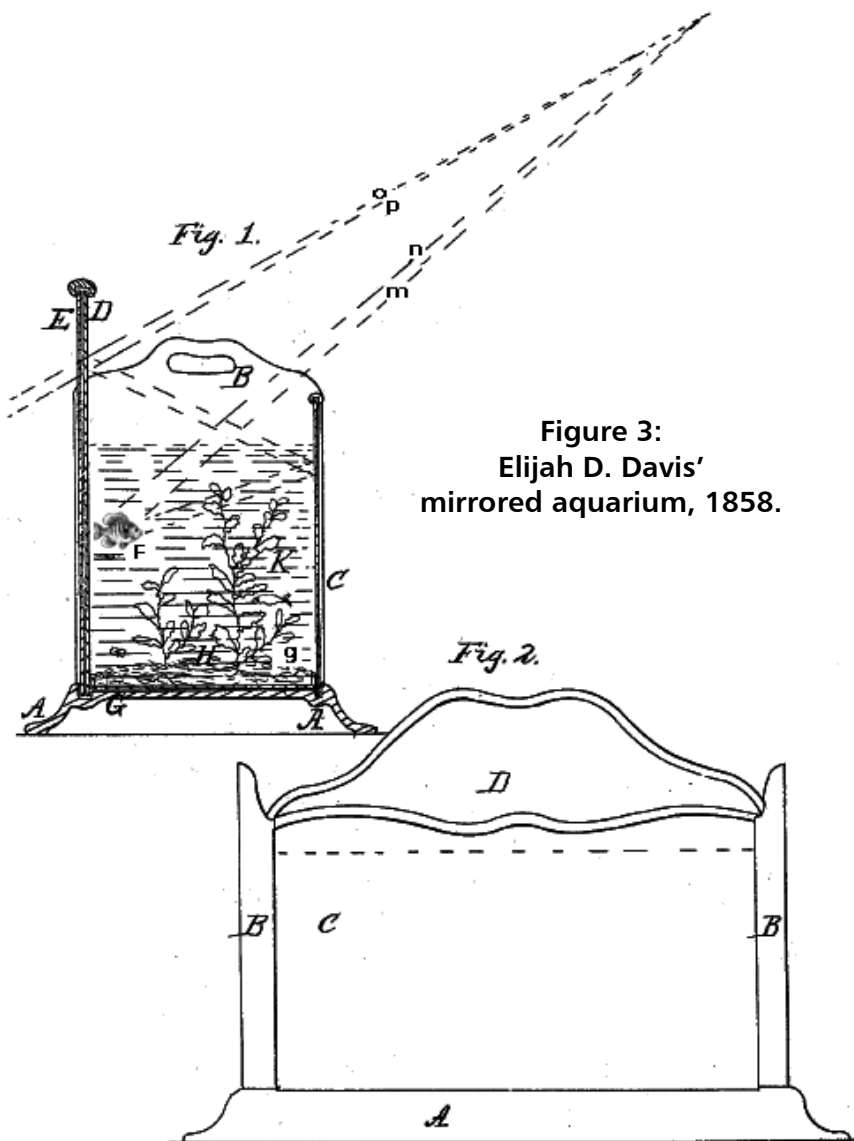

Figure 3:
Elijah D. Davis'
mirrored aquarium, 1858.

as represented. Under these circumstances so strong is the reflection offered by the front **C** to light coming to it from the rear that but little if any difference is perceptible to the unpracticed eye between the strength of the images once and twice reflected, or in other words, of images **n** and **o**. This effect is produced only in certain positions of the eye since as the spectator walks backwards from the aquarium, all the images which depend on the reflective power of **C** vanish suddenly at a certain point. It seems to me that this is lot of expense for an experience - like holograms - that last but a short time.

Davis also incorporated a false bottom in his tank so that the plants and gravel could be lifted out without disturbing the plants.

[Figure 4, *Improvement in Aquaria*, Number 31040] The third U.S. patent was an aquarium de-

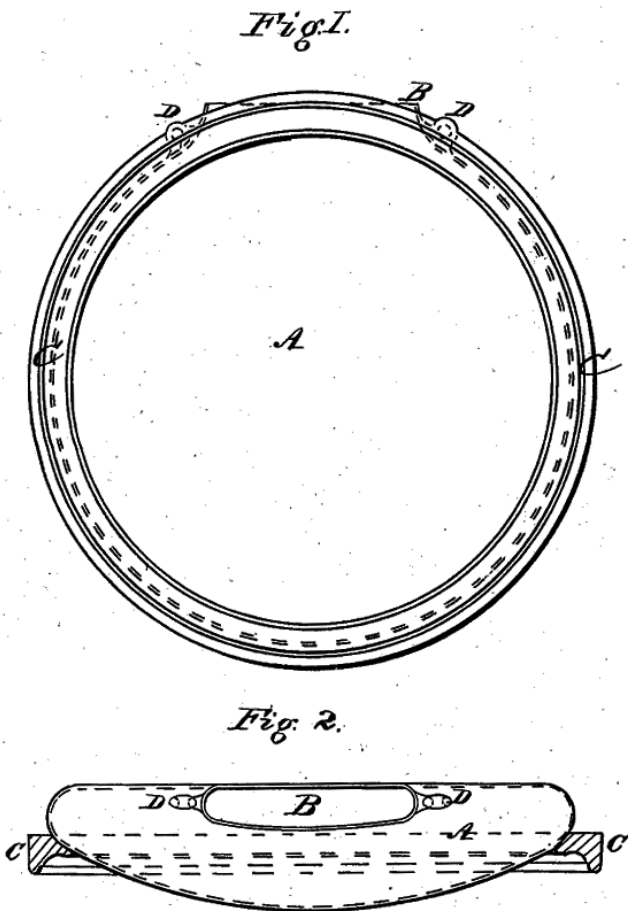

Figure 4: Herrmann Schlarbaum's wall aquarium, 1858.

signed to be mounted on a wall and was granted in 1861 to Herrmann Schlarbaum of New York City. Since it is such an early patent, for historical reasons it is worthwhile to quote from his application: "At the present moment aquaria are very expensive, besides being rather clumsy, liable to leaks and accidents, and cannot easily find a place in the parlor, in consequence of which an extra stand or table must be consigned to them, often required for more needful things." In Schlarbaum's diagram, **A** is a flat, oval, or round vessel blown of clear glass placed in a suitable picture frame **C** and **B** is the opening in the top of the aquarium. Two screw eyes **D** were attached to the glass tank next to the opening so that the aquarium could be fastened to the wall. Schlarbaum commented that larger aquaria may be made by having the back and sides of china, earthenware or even cast-iron, with plate-glass put tight in the front. The depth of these glass vessels requires them to be only sufficient to admit the turning round of the animals, and need consequently not project more than eight or nine inches. Nonetheless, such an aquarium would be extremely limited in the choice of fish and plants, in addition to being especially difficult to maintain.

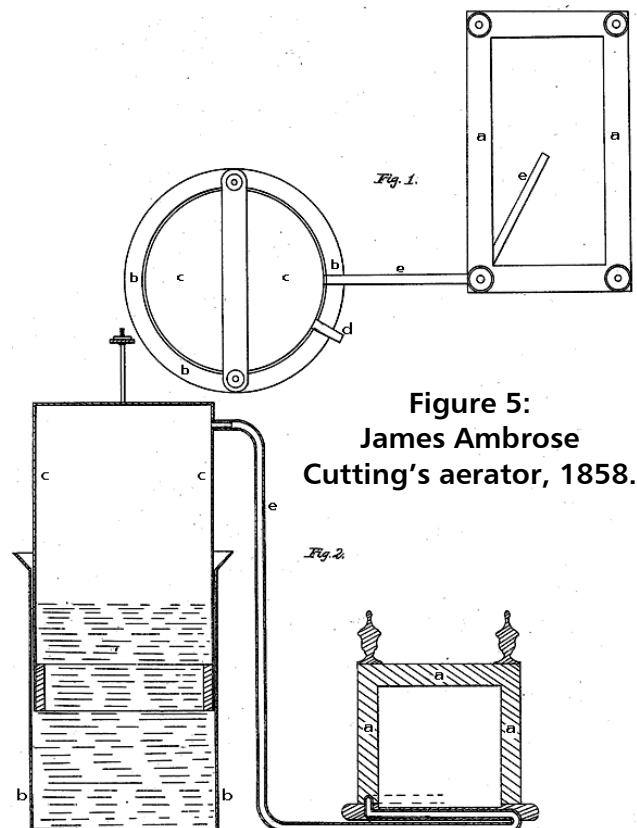

Figure 5: James Ambrose Cutting's aerator, 1858.

The next wall aquarium patent would not appear until close to the end of the Nineteenth Century.

[**Figure 5, *Improvement in Aquaria, Number 31657***] This patent was awarded two months later in 1861 to a famous name in the history of the aquarium hobby, James Ambrose Cutting of Boston. This was an aerator made of glass and rubber tubing. The principle was similar to the gasometer or old-fashioned gas storage tanks of some years ago. The principle of Cutting's aerator can be explained as follows. Suppose, for example, that you invert a tumbler over a pot of water. The air inside is, of course, trapped, but if a hole were drilled in the end of the tumbler and a piece of tubing inserted to lead the air off into an aquarium, gravity would force the air out of the tumbler through the hose to the aquarium.



Figure 6:
George T. Palmer's combination aquarium
and herbarium, 1864.

In the drawings, **a** represented a tank or aquarium for containing fishes, aquatic plants, etc., and wholly or partially filled with water. **b** is a stationary cylinder or other shaped receptacle, partially filled with water, within which was inserted another cylinder or vessel **c** so as to be free to play up and down therein. The inner cylinder, **c**, was supplied with air by means of a pump, bellows or otherwise through an aperture, **d** located near its top, until it received the desired supply when the aperture **d** was closed. Then the cylinder **c** was allowed to descend gradually by its own weight, and thus compressed the air contained in it between its top and the surface of the outer receptacle, **b**. The inner vessel, **c**, being connected by means of a flexible pipe **e** with the aquarium **a** would thus constantly force a supply of air into the tank **a** until it had wholly descended and could again be charged with air as before, using an air pump connected via **d**.

In addition to its employment at Cutting's *Aquarial Gardens* in Boston, this method for aeration was also adopted for use by Henry D. Butler at Barnum's American Museum in New York City.

[**Figure 6, *Design for an Aquarium on Fish Tank, Number D1988***] This patent was assigned in 1864 to George T. Palmer of Brooklyn, New York. This was a combination of a flat-sided oval aquarium on top of a herbarium pedestal, the bottom part of a fish tank forming part of the pedestal. This particular patent was almost lost since the text, which was not in print but rather written by hand, is faint and almost impossible to read; I had to use a special program to decipher it. However, as a design patent, the text does not supply much additional useful information.

[**Figure 7, *Improvement in Globes for Fishes, Number 46801***] We'll complete this first decade of patents by examining the sixth one, awarded to Alfred Ivers of New York City in 1865. As Ivers stated: "The object of this invention is to supply water to the receptacle for fishes, and allow the same to pass away from the bottom after the water rises to a given height or to cause the water to flow away over the top and outside of the vessel." How much of an aesthetic effect was produced by water running over

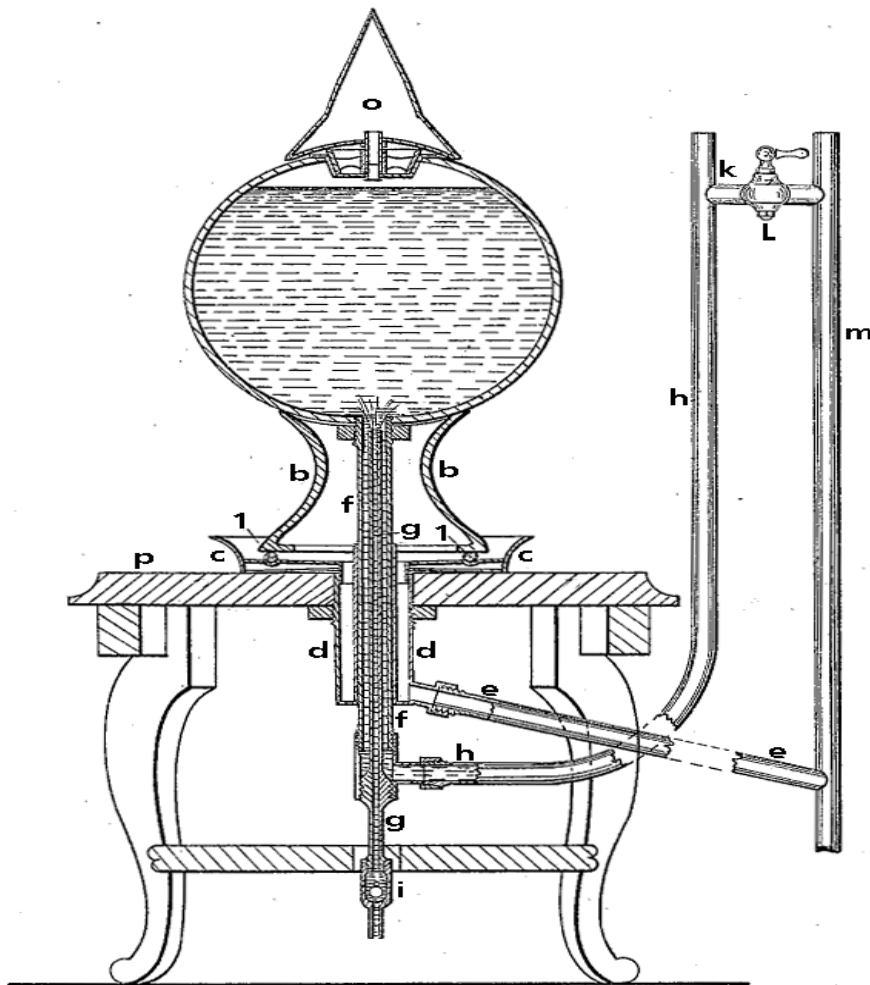

**Figure 7: Alfred Ivers's
flowing water fish globe, 1865.**

the outside of a fish bowl, however, is anyone's guess. A plus was that the only air getting to the aquarium would be that from this overflow. Since the device was never pictured in any aquarium book or mentioned in any article, we can safely assume that Ivers' innovation was not a best seller and we award to Ivers the award for the first "Rube Goldberg" aquarium patent of record.

In the drawing, **a** represented a globe or other receptacle for fishes set upon a base, **h**, which could be of glass and hollow, containing a colored fluid or painted inside, or be of any desired ornamental character. **c** is a pan in which this base **b** stood, being supported by small blocks **1/1**, of India-rubber or other material so as to allow a space between the pan and the bottom of the base. This pan **c** connected at the middle with a pipe **d** from the lower portion of which

a pipe **e** led away to a sewer or other discharge point for the water.

Up through the pipe **d** was another pipe **f** that connected with the lower parts of the globe **a**, and within this pipe **f** was the supply water-pipe **g** that passed up a greater or less distance toward or into the globe. These pipes were fitted with suitable couplings and connections of any convenient character. Pipe **d** shows an interior sleeve rising above the pan **c** to pass the pipe **f**. The lower end of the supply-pipe **g** was formed with a coupling and a ball-valve at **i** to control the flow of water into the globe.

From the lower portion of the pipe **f** was a pipe, **h**, leading off through the floor or in any other convenient manner to a closet or other place where the pipe could conveniently be carried up higher than the level of the globe, as at **k** where a cock, **l** was provided to the pipe **m** that connected with the sewer or discharge pipe **e**. When the cock **l** was open, **h** acted as a standpipe to the globe and thus the water in the globe could never exceed the level **k**. The water would pass in through the supply pipe **g** and run out through the pipe **f**, thence up the pipe **h** and escape by the cock **l** to the pipe **m**. If this cock was closed, the water would rise in the globe until it overflowed and ran down the outside into the pan **c**, thence by the pipes **d** and **e** to the sewer. Thus, either way a supply of fresh water was maintained and no harm could result from an overflow. Finally, an ornament could be placed over the globe, as at **o**, supported by a metallic or a glass bridge across the orifice of the globe. The ornament **o** could be of hollow glass, painted or filled with colored liquid. This apparatus was placed on a table **p** or supported in any convenient manner.



THE EARLY YEARS: THE DECADE OF 1869-1878

[Figure 8, *Combined Aquarium, Bird-Cage and Flower-Stand, Number 164074*] The idea of combining a birdcage with an aquarium started with Leonhard Thurneysser around 1572 and surfaced again when Gilbert White described a variation in 1782 and Shirley Hibberd pictured another in 1856, but the first such patent in the United States was

granted in 1875 to James Chase of Rochester, New York who combined an aquarium with a birdcage and a flower stand. The aquarium was square in cross section with a rectangular birdcage running through its center. Flowerpots were situated at each corner (in the drawing one of the flowerpots has been removed), and a fifth one was suspended in a basket that overhung the whole works.

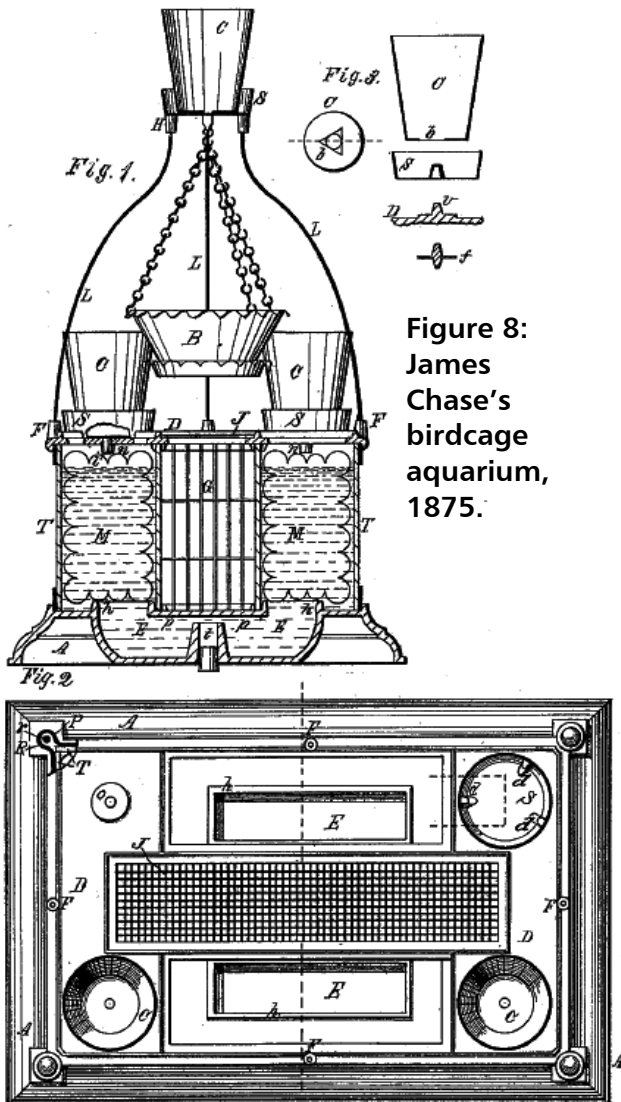

Figure 8:
James
Chase's
birdcage
aquarium,
1875.

Figure 1 is a transverse vertical section on the dotted line x in Fig. 2, a portion of cap **D** and one saucer being broken away to show the central pivot *i* of the latter and its connection with the cap. Fig. 2 is a top view, the hanging basket and upper crock and saucer and two of the lower crocks and one saucer being removed. Fig. 3 shows modifications in the construction of the crock and saucer and the method of attaching them to the cap **D** and to each other.

[Figure 9, *Aquarium, Number 192595*] Another birdcage design was patented in 1877 by Matthew Palen and Daniel Sexton of San Bernadino, California. This model was the height of ingenuity. The ends of an arch with a square cross section faced with glass were placed in two pans filled with water. All this was placed over the birdcage. An air pump was then attached to a one-way valve at the top of the arch and evacuated the air, allowing it to fill with water. The fish then were able to swim from the pans into the arch where they could be viewed simultaneously.

Figure 1 was a perspective view. Fig. 2 was a sectional view, showing the combination with a birdcage. **A A** represented two tanks, reservoirs or vessels of an aquarium that could be located at any desired distance apart. **C** was an arched or siphon-shaped chamber, the opposite sides of which were

made of glass and the ends of which were open. This arched or siphon-shaped chamber was arranged so that it connected the two tanks **A A** in the manner of a bridge, and it was supported so that each of its open ends terminated inside of one of the tanks. In the top of this arched or semicircular chamber was placed a valve **d** at the highest point that provided a means for attaching an air-pump **E** over it so that when sufficient water was admitted into the tanks or reservoirs **A A** to cover the ends of the curved chamber, the air in the chamber could be exhausted through the valve **d** by means of the pump **E**. The atmospheric pressure upon the water in the tanks **A A** would force it up into and fill the curved chamber. The pump could then be removed and a perfect semicircular column of water would be maintained in the arch into and through which the fish could pass from one tank or reservoir to the other, thus producing a peculiar and interesting effect.

This same device could be used in a single tank, the only necessity being that the open ends of the curved

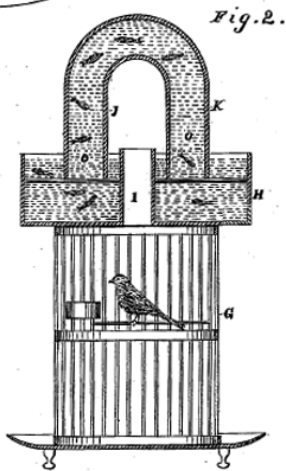
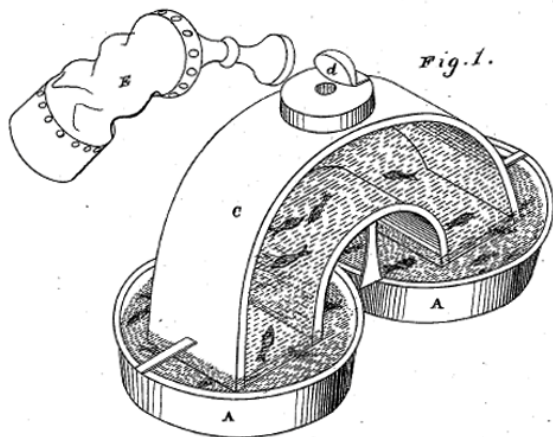

Figure 9:
Matthew Palen
and Daniel Sexton's birdcage
aquarium, 1877.

or other shaped chamber be submerged below the surface of the water in the tank. This column of water would be thus maintained for a long time, and, where fresh water was continually supplied to either tank, a circulation would be established through the arched chamber that would keep it fresh.

Another adaptation of the invention was shown at Fig. 2, in which was represented a very unique combination of this principle with a bird cage, as follows: **G** was a bird cage, upon which was constructed a tank or vessel, **H**. **I** was a central opening which leads up from the bird cage through the center of the pan or vessel **H**. The walls of this central opening were as high as the outside walls or rim of the pan or vessel. Over this central opening was placed a bell-shaped glass or receiver **J** that was somewhat larger in diameter than the opening **I**, and which was supported at such a height from the bottom of the pan or vessel **H** that the water would rise above its lower edge. Outside of this receiver was placed another receiver, **K** of larger diameter that was similarly supported, so that the space **O** between the two would form a bell-shaped chamber while the interior of the smaller receiver **J** communicated through the passage **I** with the bird cage.

Before filling the pan or reservoir **H** with water, one end of an elastic or other tube was placed in the space between the two receivers so that it would terminate at the highest part of the space. The opposite end of the tube was connected with an air pump outside of the receivers so that when the pan **H** had been filled until the water stood above the lower edges of the receiver the air could be exhausted from the bell-shaped chamber and the water raised by atmospheric pressure to fill the space **O** between the two receivers. The tube could then be withdrawn. The fish in the vessel or tank **H** could then pass up into the space **O** between the two receivers and swim around at pleasure, while the birds in the cage could rise through the passage **I** into the inside receiver, thus giving the appearance of birds playing with the fish as the water would not rise above the walls of the opening **I**.

Because of the difficulty of sealing an arch of this sort in those days, if such a device had been built I imagine that the canary would have also had a built-in bird-

bath. This concept of a “fish bridge,” however, would appear again in the 1930’s.

[Figure 10, *Improvement in Fountains and Aquariums*, Number 143456] A patent that combined aeration with cleaning was awarded to Jonathan Moore of Brooklyn, New York in 1873. **A** was the basin of the fountain and **B** the water-supply pipe, the nozzle of which was not represented. **C** was the overflow pipe, extending up through the bottom of the basin concentric to the water supply pipe **B**. Its upper end was open and adjusted at the level below which the water in the basin was never to be allowed to sink. **D** was an exterior casing, having a partial cover, **D'** and openings around the base within the bowl, as indicated by **d d**. **E** was a flared support, the place of which could be supplied in practice by any ornamental stand.

The water received through the pipe **B** from an elevated reservoir or other source fell into the basin **A** and mingled with the mass there already stored. The constant accession from this source was balanced by a corresponding escape of water from the bottom of the basin **A** by its flowing inward through the passages **d** into the chamber **D**, whence it escaped by flowing over into the interior of the large pipe **C**, which formed an opening concentrically around the jet-pipe **B**. Below the base of the fountain the large pipe **C** and the smaller pipe **B** could separate and extend in different directions, as convenience dictated.

The water in a fountain-basin of this character was sure to be properly aerated. Fish are more likely to die in ordinary fountains and aquariums from an accumulation of stagnant water and filth in the bottom than from any other cause. This invention provided for a constant change of the water down to the extreme bottom of the fountain. The concentric position of the pipes **B** and **C** simplified the construction of the fountains by necessitating only one aperture therein. The basin could be of any suitable form to serve as a fountain or aquarium and could also be of any material desired.

[Figure 11, *Fountain Aquarium and Flower Pot Stands*, Number 147849] During this period, two patents were issued that involved fountains. The first went to Thomas Leslie of Brooklyn in 1874 (Brooklyn

early on supplied many aquarium inventors) and was a combination of fountain, aquariums and flower pots (seven flower pots are shown in the figure).

Figure 1 was a plan view of the stand and Figure 2 was a vertical section. **A** represented the cone-shaped stand which according to size and place where used was intended to be made of either cast metal or sheet metal. For the purpose of making supports or shelves for the flower pots or boxes **C**, the cone as shown at **D**, Fig. 2 was diminished in area, so as to leave a ledge projecting outward therefrom to form a support for one side of the flower pot or vase, while the opposite side of the pot or vase was supported by a flange **E** on the upper edge of the outer wall **F** of the water troughs or basins **G**. Each of these basins were so proportioned in diameter as to receive the overflow of water from the one next above, while the basin at the base of the cone finally received the surplus water that by means of a pipe **I** was carried off to the central waste water pipe **J**. In connection also with this waste water pipe were conduit pipes **K** from the sides of the several basins. The object of these pipes was to allow the basins to be cleaned when required, which was effected by opening the screw-caps **L** within the basins. At the point **M** was a small basin with a perforated lip or flange that was intended to cause the overflow of water from it to fall somewhat in a sheet down the upper face of the cone to the uppermost basin and flowerpot stand. For the purpose of supplying the water, a pipe **H** was carried up through the waste water pipe and out at the apex of the cone, which was capped with a sprinkler **P** having a suitable cock **E** in its stem to cut off or regulate the flow of water through it.

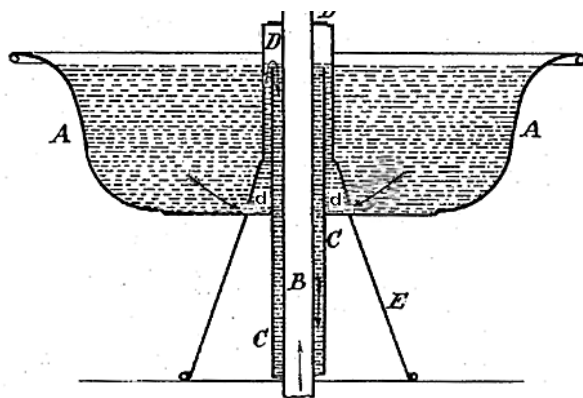

Figure 10: Jonathan Moore's aerating and cleaning device, 1873.

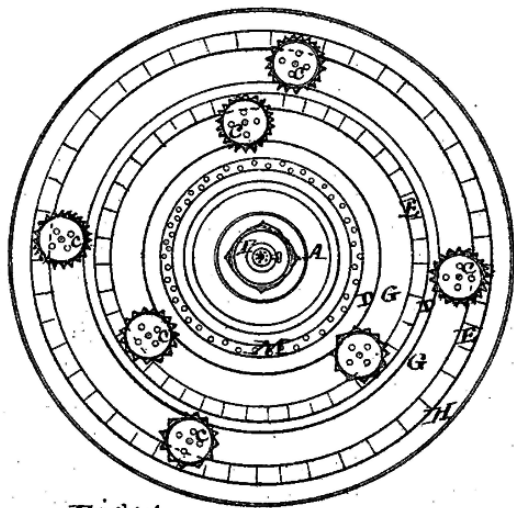

Fig. 1.

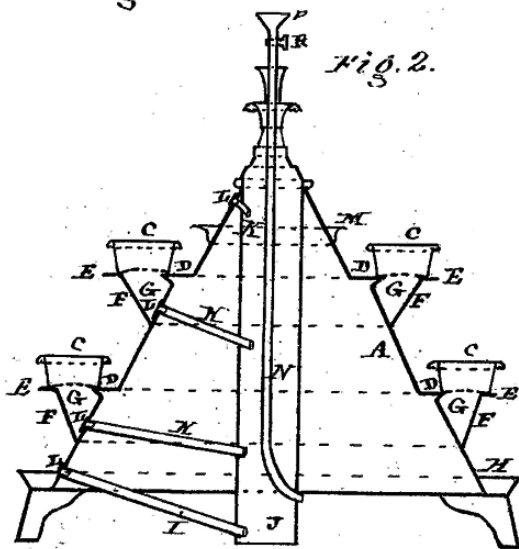

Figure 11. Thomas Leslie's fountain aquarium, 1874.

[Figure 12, *Combined Aquarium, Fountain and Flower-Stand*, Number 188941] The second patent awarded to Alphonse Peltier and Matthew Hoerning of Williamsburg, New York in 1877. This also was a combination aquarium and flower stand. Figure I is an elevation view, partly in section, of our combined fountain, flower stand and aquarium. Figure II is a top view and Figure III is a sectional view on line x x in Figure I.

The operation of the fountain was as follows: The reservoir E was filled with water through tube K until the float L was forced up against the lower end of the tube. Water was then poured into the tank N nearly up to the top. The water would consequently run through

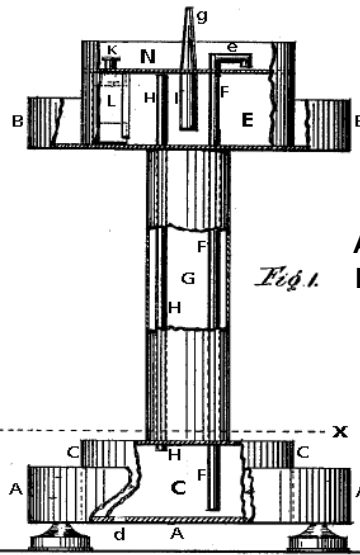

Fig. II

Fig. III

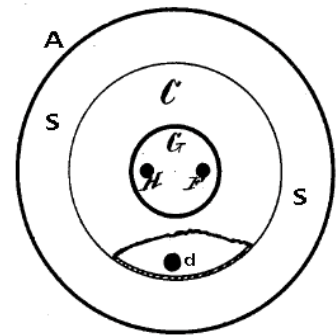
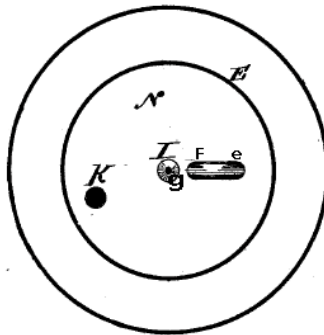

Figure 12. Alphonse Peltier and Matthew Hoerning's fountain Aquarium, 1877.

tube F into the reservoir G and expel the air from it through tube H into the reservoir E, where the thus compressed air pressing on the top of the water in the reservoir caused the water to be elevated through tube I and nozzle g into the tank N and producing the fountain effect. After a certain time the fountain would cease to flow and the water in reservoir G then had to be removed through the opening d and the process was started over again. This was, of course, time-consuming and the fountain could not have run for very long and we therefore award Peltier and Hoerning the award for the second Rube Goldberg patent.

[Figure 13, *Improvement in Aquariums*, Number 165639] The last patent of this period was far ahead of its time. This was the brainchild of Jerome Wenmackers of Philadelphia who in 1875 invented the first walk-through aquarium. Figure 1 is a front view; Fig. 2 is a transverse sectional view and Fig. 3 a plan view of the aquarium.

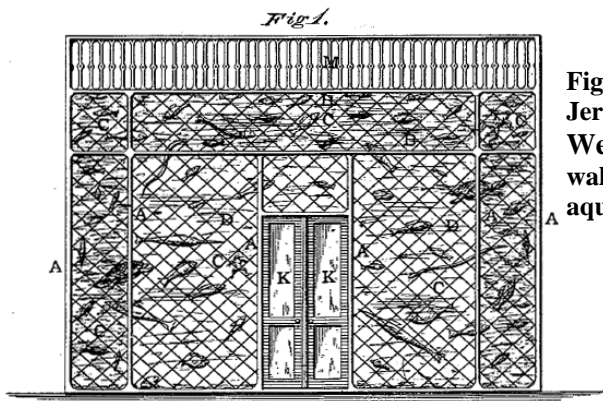

Figure 13:
Jerome
Wenmacker's
walk-through
aquarium, 1875.

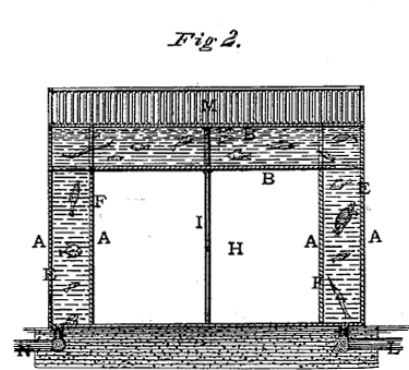

Fig. 2.

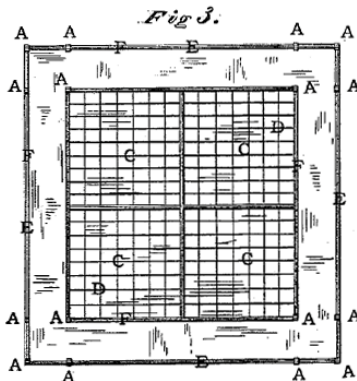

Fig. 3.

The object was to construct an aquarium in such a manner that there would be a space within surrounded by the water and the fish into which space visitors could observe the fish. It consisted in constructing an entire outer as well as inner wall of iron frames and glass plates, between which walls the water and fish were contained, the whole forming a double wall about an inner saloon accessible by doors through the double wall. A balustrade could surround the top, which with a suitable covering would make an additional area for visitors and at the same time would protect the fish and keep the water clear.

The glass was relieved from the weight of the water by means of a metallic network covering the outer surface of the glass, which network was at once highly ornamental, relieving the glass from the inside strain, and protecting it from outside injury. In the figures **A** represented the upright posts and **B** the horizontal girders of the frame of the aquarium. These posts and girders were made of metal and were rabbeted in the usual manner to receive the plates of glass **C** that formed the walls of the receptacle for the water and the fish. The glass was bedded in India-rubber or other pliable substance and leaded in the usual manner. To

relieve the glass from the strain, which in large aquaria had been very disastrous, the rabbet of the frame was placed first before putting in the glass. A metallic network **D**, which was on the outside surface of the glass, relieved the glass from strain by reason of the pressure of the water.

The outer wall **E** and inner wall **F** were constructed in the same manner, one within another, as shown in Fig. 3, forming the double wall of the saloon **H**. Within the saloon **H** were standards **I** supporting the top, which was also double and contained water and fish. The saloon **H** was surrounded on all sides with the double wall containing water and fish, and the bottom also was in like manner constructed. The doors **K** in either side passed through the double walls, and were for entry from the saloon **H**. Surrounding the top was a balustrade **M** and as the glass was covered by the netting **D**, visitors could visit the top of the aquarium also. To renew the hollow walls with water, the inlet-pipe **L** and outlet pipe **N** from some suitable reservoir was used. The bottom and foundation were made of stone and cement and constructed solid, or it could be formed for the reception of fish and covered with glass and the netting **D**. In the winter the water could be removed from the hollow walls and its place supplied with vegetation, forming a beautiful herbarium.

Since the metal mesh also covered the top of the building, Wenmackers suggested that people could also walk on the top and view the fish below their feet. The idea was untenable at the time since the weight of the water was such that the metallic network could not relieve the stress upon the glass. In short, a person would literally be risking life and limb by venturing into its interior (or, for that matter, walking on its roof), assuming that the structure would still be standing once it was filled with water. Nonetheless, the walk-through aquarium was finally implemented successfully towards the end of the Twentieth Century when the technology of high strength plastics became available.



EDISON INVENTS THE ELECTRIC LIGHT BULB: THE DECADE OF 1879-1888

[Figure 14, *Combined Aquarium and Maritime Theater, Number 324508*] Wenmackers also created the much more elaborate and practical public aquarium design shown in his 1885 patent. This invention was intended to combine the useful and instructive features of an aquarium with the entertaining features of a maritime theater, in which historical and nautical plays could be performed. The invention consisted of a combined aquarium and maritime theater in which was arranged a maritime stage in front of a permanent stage and between it and the auditorium, the maritime stage being formed by a tank of sufficient depth and width, the ends of which were connected by a U-shaped channel that extended below the galleries. The maritime stage was supplied with water from the different tanks of the aquaria, and separated by partition walls from the latter. The bottom of the water tank and connecting channel was made in part of transparent glass panels, which formed the ceiling for the story below so that the fish in the tank and connecting channel could be observed from below.

Figure 1 represents a vertical transverse section through the aquarium and maritime theater on line *z z*, Fig. 2, and Figs. 2 and 3 are horizontal sections of the same, respectively, on lines *x x* and *y y*, Fig. 1. The first story was devoted to purposes of refreshment and contained, besides the vestibule and halls, a large room used for a restaurant, kitchen, winter garden and other accessories. The second and third floors were used for the theater, the aquarium proper being located on the second floor where a number of tanks, *A A*, were arranged, which received direct light through the windows of the building during the day so that the fish and other objects of interest could be readily observed in the tanks. The tanks were supplied with salt water in any suitable manner, which water is then discharge *d* into a large tank, *B*, that extended across the full width of the building, and that was located intermediately between a permanent stage, *C*, and the auditorium *D*.

A proper space *E* for the orchestra was arranged close to the tank *B*, which was provided with in-

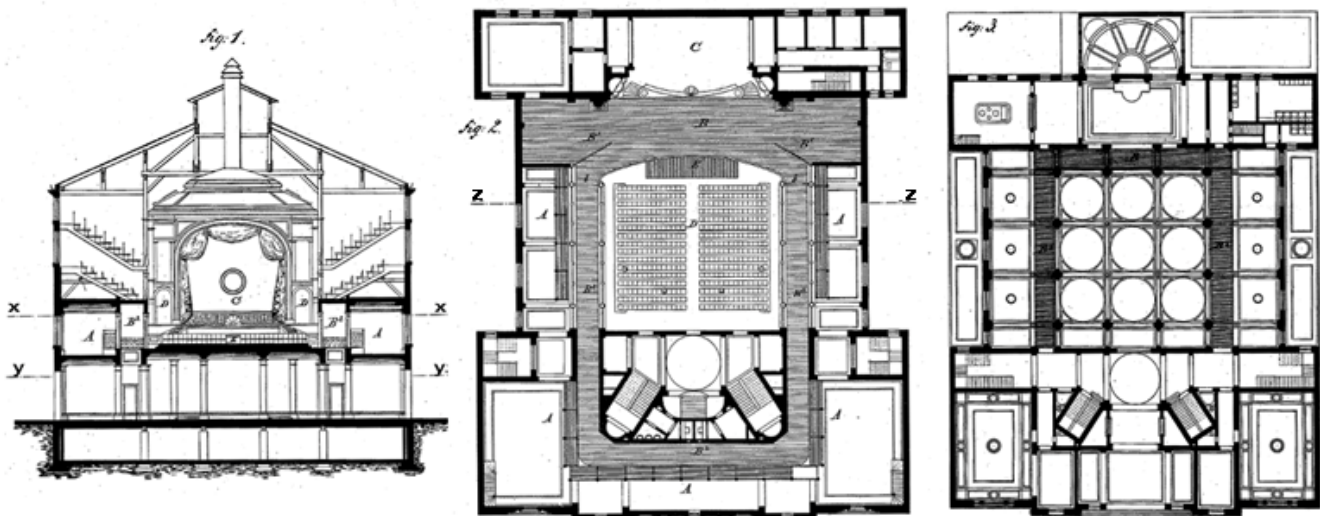

Figure 14: Jerome Wenmackers' aquarium and maritime theater, 1885.

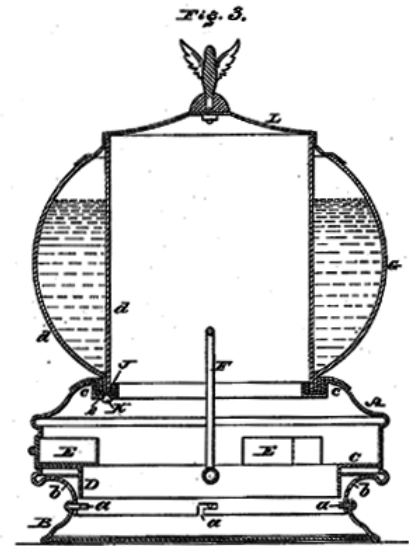
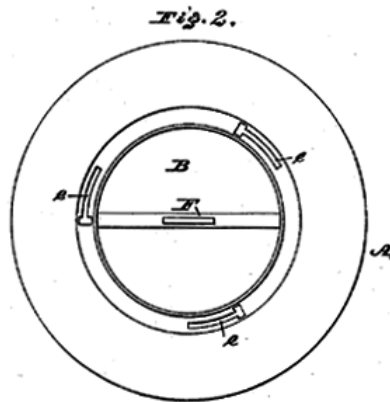
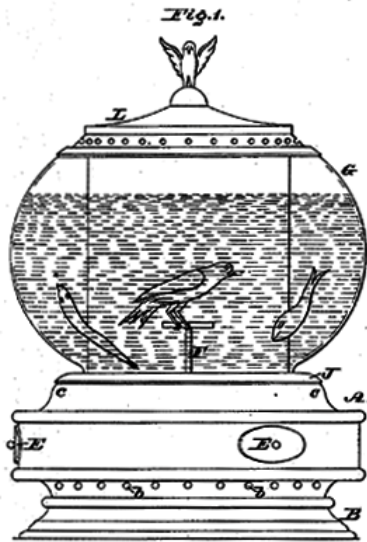

Figure 15:
August Ledig's
birdcage aquarium, 1884..

clined wings **B'** in front of the proscenium, said wings extending into the tank **B** and serving to hide the corners of the tank from view. A U-shaped connecting channel, **B²**, extended below the galleries and immediately adjoining the series of aquarium tanks **A**, from one side to the other side of the tank **B**, as shown in Fig. 2, the channel being closed by partitions at both sides, so that it could be seen from the orchestra seats and galleries nor from the rooms in which the aquarium tanks were located. The tank **B** in front of the stage **C** and its connecting channel **B²** formed a so-called "maritime stage" which served the double purpose of a tank for the larger kinds of fish and as a water stage for displaying vessels of all kinds, so that nautical spectacular plays could be performed in connection with the permanent stage **C**.

The connecting channel **B²** admitted vessels to pass from one side of the maritime stage **B** to the other side, as required for the purposes of the performance. The bottom of the tank **B** and of the connecting channel **B²** was made of thick panels of glass, which were tightly secured against leakage and which formed at the same time the ceiling for the first story, so that persons sitting in the restaurant below could see the water and observe the fish in the tank, as the space above the same was sufficiently lighted up during the day and night. The proper pipe connection between the aquarium tanks and the main tank **B** and connecting-channel **B²** could be made in any approved manner. To reduce the danger of accidents

arising from leakage and flooding of the main tank **B**, the same could be shut off from the channel **B²** by hinged or sliding transverse partitions **b b**, which were also placed in position whenever the cleaning of the tank or channel was necessary. The available space in the building not occupied by the aquarium tanks **A** and stages **B** and **C** were utilized for the display of various scientific objects, so that the entire structure furnished attractions for children and grown people, as it combined instruction with amusement. This was an ambitious proposal indeed, although I am not sure that I would like to be one of the first restaurant customers with so much water over my head!

[Figure 15, *Aquarium*, Number 296853] Another birdcage aquarium patent surfaced during this period, the much simpler design issued in 1884 to August Ledig of Philadelphia. The invention consisted of a combined birdcage and aquarium whereby a bird may appear to be living within the water. Figure 1 is a side elevation of the birdcage and aquarium, Fig. 2 is a top view of the base portion and Fig. 3 is a central vertical section of Fig. 1.

When the aquarium required renewal with water, cleansing, etc. or if access to the bird was desired, the globe was removed and the body of the cage was substituted, the lugs **K** being fitted in the wide parts of the slots **e**. The body was then turned so that the heads of lugs engaged under the narrow parts of the

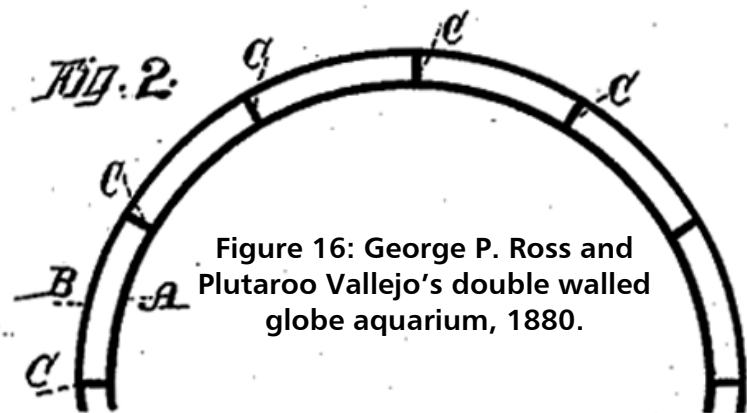
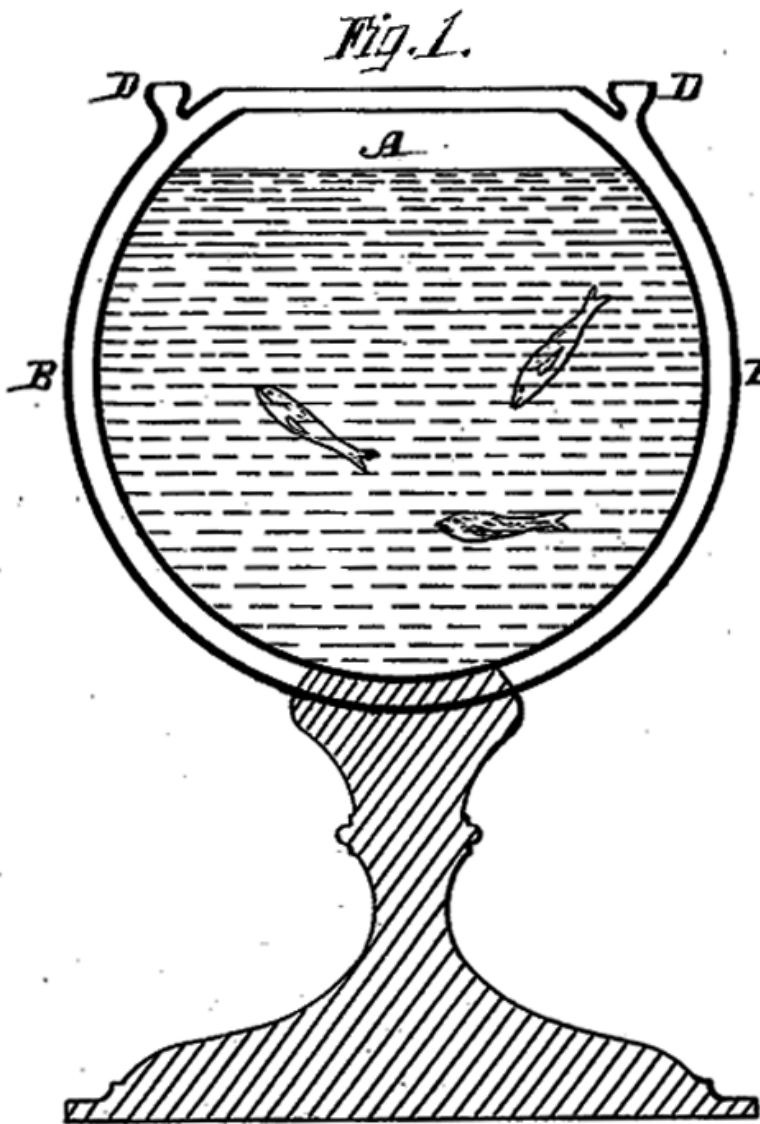

Figure 16: George P. Ross and Plutaroo Vallejo's double walled globe aquarium, 1880.

slots and the body and base were connected, the body covering the bird as in ordinary bird cages. When the aquarium was removed, the perch F and

open top of the base were exposed, allowing the bird to fly away but to prevent this, the upper portion H of the birdcage was used and applied to the base A, securing it by the lugs K that entered the slots e of the base. Half of the portion H of the cage in Fig. 2 is shown to illustrate the location of the base and how the cage aligned in position with the aquarium. This was the last birdcage within an aquarium patent and good riddance. Under such close confinement it clearly was inhumane for the birds.

[Figure 16, *Double-Walled Glass Fish-Globe, Number 233435*] Two globe-type aquariums were patented during this period. The first was a double-walled aquarium by George P. Ross and Plutaroo Vallejo of Bristol, Nevada in 1880. This invention consisted of a doubled-walled aquarium having an intervening space or spaces, within which various colored fluids could be placed so as to give an unusual or attractive appearance to the contents of the globe or vessel. Figure 1 is a view of a globe and Fig. 2 is a section.

A is a globular or other shaped vessel filled with water and containing ornamental fish. Outside this globe was formed a second inclosing-globe B that could be connected to or supported from the inner globe at any desired distance from a half-inch upward. In some cases this exterior space could be subdivided by vertical partitions C so that if desired, differently-colored liquids could be placed in each compartment or the whole space surrounding the inner globe could be continuous so that a single color surrounded the interior compartment.

At the top of this exterior compartment a nozzle or nozzles D were formed to receive the colored liquid that was to be used, made in any ornamental form desired. By this construction the globes

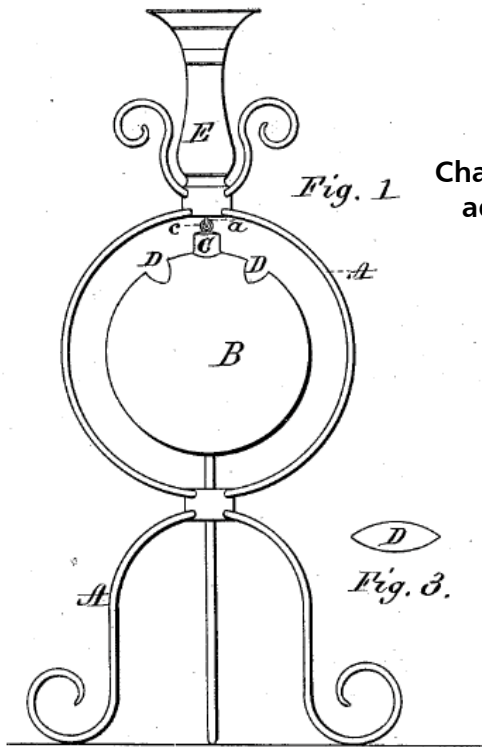
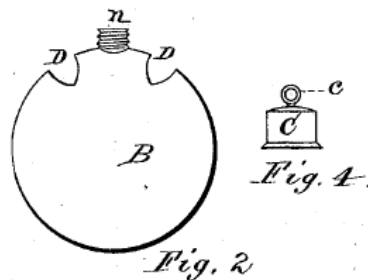

Figure 17:
Charles N. Orpen's globe
aquarium and stand,
1882.



thimble **C** is an eye **c** by which the globe **B** could be suspended from the hook **a** in the stand **A**. Upon each side of the thimble the upper portion of the globe was provided with the oval openings **D** so that a current of air was maintained upon the surface of the water in the globe. Through these openings the globe could be filled with water and fish or water plants introduced. The upper portion of the stand **A** could, if desired, be provided with a vase or receptacle **E** for flowers.

[Figure 18, *Elevator and Fountain*, Number 225646] The first real novelty aquarium was patented in 1880 by Amzi A. Sanford of Mont Clair, New Jersey.

could be tinted any desirable color, perhaps to correspond with or contrast with the tint of the room in which the fish are to be kept. In any event, the fish or other contents of the globe or vessel will be tinged with the color used by being seen through it. If vertical partitions were employed and a number of colors placed around the globe, the moving fish will take up the colors alternately through which they were seen. This would be a useful invention if the colored liquid colored only the fish (as with a Gro-Lux lamp). As it is, this invention is a terrible idea.

[Figure 17, *Aquarium*, Number 256240] A more practical aquarium but rather ornate one was that of Charles N. Orpen of New York City in 1882. Figure 1 is a view of the fish globe and stand, Fig. 2 is a view of the globe, Fig. 3 is a view of the slot or opening in the globe and Fig. 4 is a view of the thimble used in connection with the globe.

A shows a tripod framework made of any suitable material and provided in its upper part with a hook **a** from which the globe **B** was suspended. The globe was usually made with a projecting threaded nipple **n** to which the thimble **C** was screwed or otherwise held in any convenient way. In the upper part of

This was a combination aquarium, elevator and fountain but in reality the principle was rather simple. The elevator was powered by the same sort of weights found in a cuckoo clock, and moved an endless chain of buckets that picked up water from the aquarium and dropped it into a tank at the top. The water then flowed back down into the aquarium via gravity through a pipe that was bent back at two right angles, leading to a nozzle that spurted the water upwards. The difference in height between that of tank at the top and the aquarium was sufficient to provide enough pressure to form the fountain spray. The elevator was enclosed in an attractive miniature building that hid the mechanism. Figure 1 is a sectional view of an aquarium and Fig. 2 is a side view of the casing and well of the elevating and discharging devices. Fig. 3 is a section on line **x x** in Fig. 1 and Fig. 4 illustrates the blank from which a bucket of the elevating device was formed.

The letter **A** indicated the aquarium, the usual rectangular box with glass walls or of any other form desired. The letter **B** indicated a casing made of wood, and from the lower part of which extended downward was a well **C** formed of tin. In the upper part of the casing was journaled a shaft **D** carrying a drum **E**

provided with flanges *e*. From the lower part of the casing projected an arm *F* inwardly. This arm carried at its inner end a flat guide *h* which was braced by a short arm *h'* secured to the front wall of the casing. In guide *h* slid an elongated plate *G*, provided with two rows of perforations *g* that were adapted to be brought into coincidence with perforations *f* in the guide, held by suitable pins passing through the coincident perforations. At its lower end the plate *G* carried a casing *I* in which was mounted a drum *K*. The letter *L* indicated a chain of buckets passing around the drums *E* and *K*.

The casing *I* carrying the lower drum stood in the well *C* that stood upon the bottom of the aquarium. It had in its wall openings *c* through which the water could enter. The shaft *D* was connected with clockwork *M* operated by a suitable weight *m* or by a spring. When the shaft was rotated by this clockwork, the chain of buckets *L* traveled on the drums *E* and *K* after the manner of a chain-pump, raising the water from the aquarium and discharging it into a box or trough *N* from which it flowed into a tank *O* located in the upper front portion of the casing. There was a pipe *P* leading downward from within the casing and well to the bottom of the aquarium. It was bent outward through an aperture in the well and connected with a bent pipe *Q* leading upward and

terminating above the surface of the water in the aquarium, or above the waterline and terminating in a nozzle *R*. The pipe *Q* was provided with a stopcock so that the flow of water could be cut off when desired.

The character of the device could be changed from the jet to a waterfall aerator by cutting off the flow of water through the pipe *Q* by means of its stop-cock and closing the valve *s* in the tank *O* at the mouth of the pipe *P*. The water which flowed into the tank *O* would then rise in the tank and flow through the elongated slot *t* in its front wall and through the coincident slot in the wall of the casing, falling in a sheet in the tank and keeping the water agitated and consequently aerated. Instead of the clockwork for driving the shaft *D*, any other suitable motive power could be used. The casing may be very greatly varied as, for instance, it could be made in a simulation of a pile of rocks, a dolphin or other animal or fish having the slot *t* in the tank coinciding with its mouth. If I had a choice of antique aquaria, this is the one I would most like to have in my collection.

[Figure 19, *Aquarium, Number 295218*] Hanging aquaria over one's head like the Sword of Damocles seems to have been a popular pastime in the Victorian era and in 1884 Fortunato Zanetti of Bryon, Texas

Figure 18:
Amzi A. Sandford's
combination
aquarium,
elevator and
fountain, 1880.

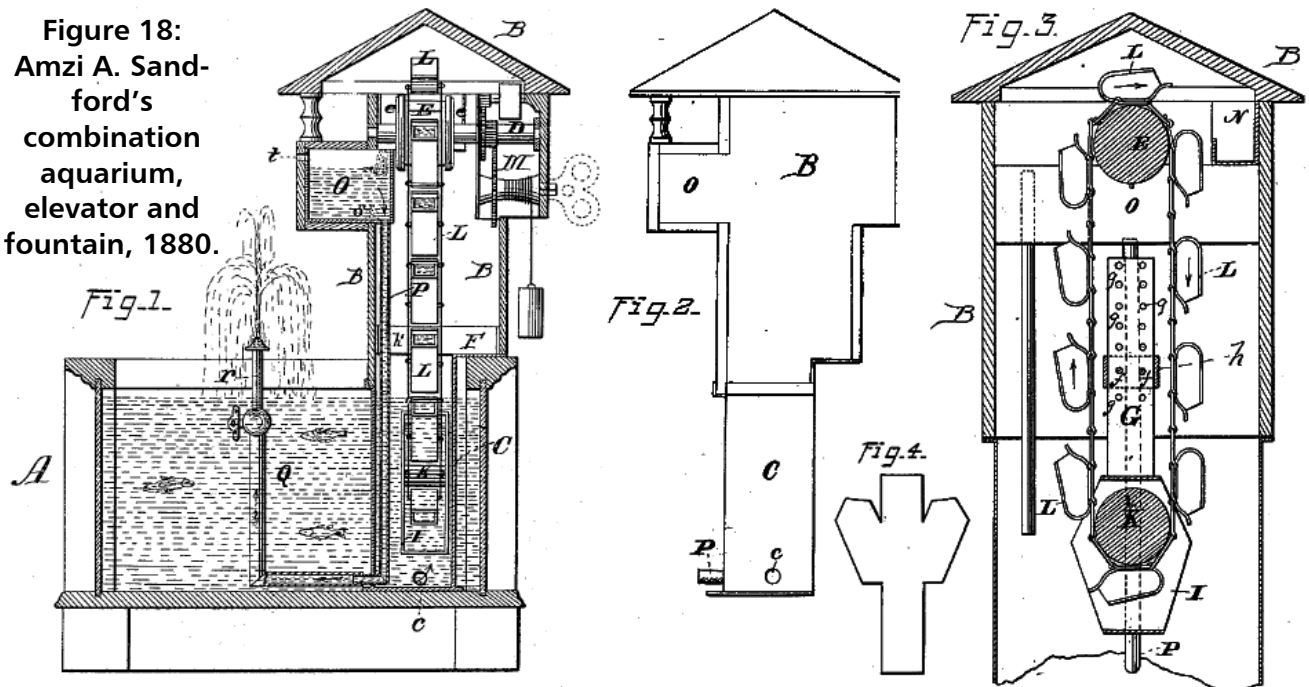

patented one. One of the interesting features of this model was the plug at the bottom that served as a drain. Zanetti envisioned colored ceramic ornaments at the top of these plugs and he illustrated four of them, a rabbit, a fisherman, a bird and a monkey. Figure 1 is a perspective view of the improved aquarium, Fig. 2 is a vertical sectional view, Fig. 3 is a perspective view of the plug or stopper detached and Fig. 4 is a perspective view showing a modification.

A in the figures designated a suitable jar or vase made of white glass in any suitable ornamental shape and supported upon three or more feet of any desired configuration. The upper edge of the jar or vase A was provided with three thickened or reinforced enlargements C C that were perforated, as at D, to receive hooks E at the ends of chains F by which the device could be suspended either indoors or out. The center of the bottom between the legs which were designated by letters B B, was thickened or reinforced as shown at G, and provided with a conical perforation or aperture H through which the water could be drained off for renewal. For the perforation H, a plug or stopper I was provided that was ground to fit nicely in the perforation. This plug, made of colored glass, porcelain, majolica or any other ornamental material contrasting with the white glass of which the vase or jar was made, had an enlarged head J which was molded or formed so as to form an interior ornament for the aquarium. This could represent a man or woman, animal, plant, rock, house or castle or, in fact, any desired ornamental object which was supported by the plug I inside the vase or jar.

In the modification shown in

Fig. 4, the vase or jar was supported upon a single foot K, making it necessary to locate the perforation for the stopper near the side instead of centrally in the bottom. In other respects the construction was the same as described above.

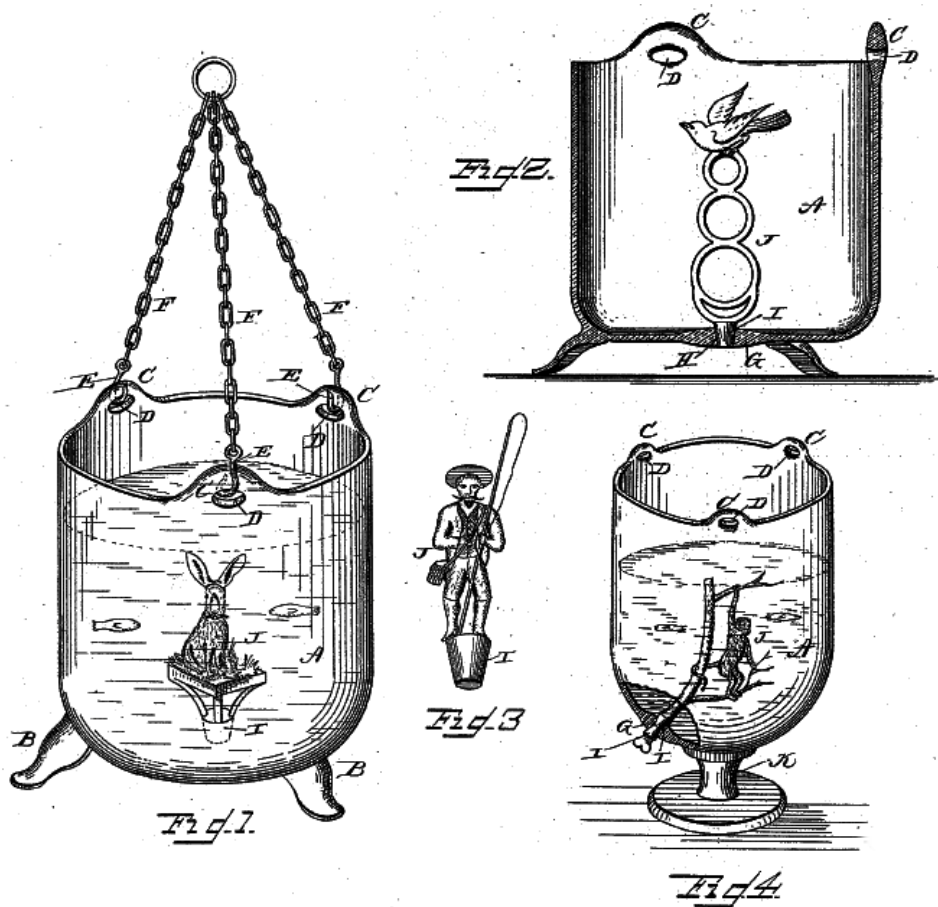

Figure 19: Fortonato Zanetti's hanging aquarium, 1884..



THE WESTERN INDIAN WARS COME TO AN END: THE DECADE OF 1889-1898

[Figure 20, *Fish Globe*, Number 415506] Patents for wall and hanging aquariums were also granted during this period. In 1899 a hanging model designed by George Gunther of New York City incorporated a method to remove sediment from the tank without disturbing the fish. The hanging globe was double-walled, opened to each other by a hole at the

bottom where sediment collected. When cleaning time arrived, the hanging tank was taken down and placed onto a special holder in a pan. When water was added to the globe, it forced the dirty water into the outer wall where it overflowed through two drainage holes, taking the sediment with it. The dirty water spilled over into the pan as shown. Figure 1 represents a vertical central section of the fish globe, showing it suspended by means of hanger chains; Figs. 2 and 3 are modified constructions of the globe provided, respectively, with a stand and with a basin for receiving the overflow from the globe and Fig. 4 is a horizontal sectional view of the fish-globe.

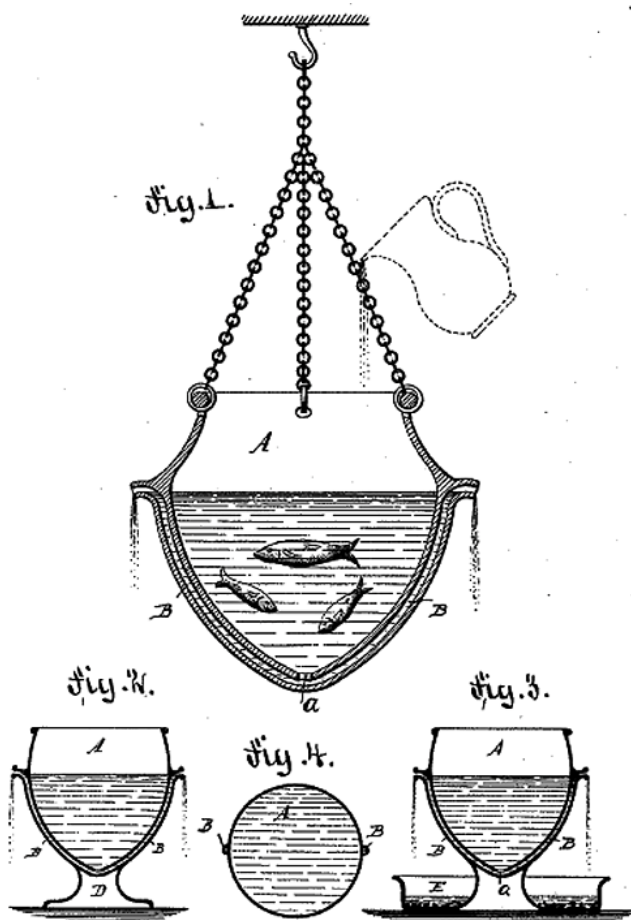
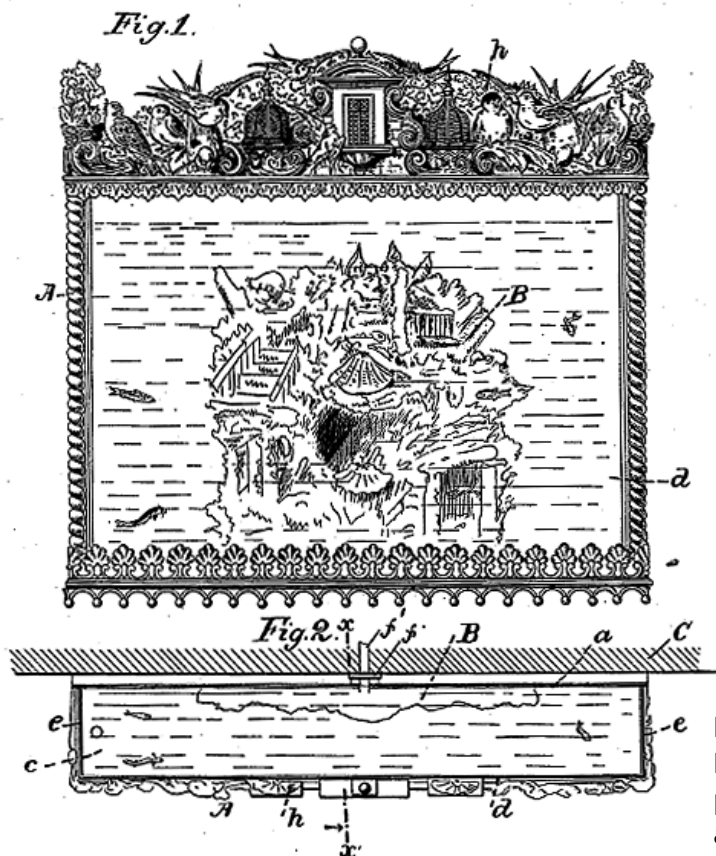

Figure 20: George Gunther's hanging aquarium, 1869.

A represented a fish globe that was provided at the lowest part of its bottom with an aperture **a** that communicated with one or more outlet channels or passages **B B** that extended from the aperture **a** along the outside of the globe in upward direction, the lower edge of the discharge apertures at the upper ends of the channels **B B** being on a level with the level of the water in the globe. The channels **B** were from one-quarter to one-half an inch in diameter and formed integrally with the body of the globe **A**. The sediment settled at the bottom of the globe and passed through the aperture **a** and was conducted through the channel or channels **B B** in an upward direction and discharged through the openings at its upper ends. The water in the globe could be changed by pouring it in from a pitcher, as indicated in dotted lines in Fig. 1, the stale water being discharged with the sediments through the outlet openings of the channels **B B**. This had the advantage that the fish were not at all disturbed and did not require to be handled or taken out of the globe.

The globe A was suspended by means of hanger-chains from a suitable support, as shown in Fig. 1 or supported on a stand D as shown in Fig. 2, in which latter case a receptacle or catch basin E for the overflow of water and sediment was arranged as shown in Fig. 3 so that the latter could be collected and utilized as a fertilizer for aquatic plants, ferns, etc.

[Figure 21, *Picture Aquarium*, Number 475404] A picture frame wall aquarium was the subject of Ernst Lochman's 1892 design. Although from Gohlis-Leipsc Germany, as with all inventions in this book by foreigners this was an American patent. The frame was rather ornate, as was the insert consisting of stones and shells fastened to the rear of the aquarium. However, this patent was an exception for the time since it wasn't until the early 1930's that patents for wall aquariums arrived anew on the scene. Lochman specified that the aquarium be made of iron or brass, a poor choice of materials because of rust and toxicity problems, respectively. Figure 1 represents a front view of the picture aquarium, Fig. 2 is a plan view showing it attached to a wall and Fig. 3 is a vertical section in the plane x x, Fig. 2.



In practice, the width of the tank was made very small compared with its height and length so that the fish were compelled to swim with their sides toward the front and could always be seen in full from the front. The tank was secured to the wall C in any usual manner; for instance, by means of the eye f on the tank and a nail or hook f' driven into the wall where the aquarium served as a wall decoration. If desired, the top of the front and side walls could be supplied with an ornamental cornice h. A suitable outlet pipe in the bottom closed by a cock g could be provided for drawing off the water without disturbing the tank.

[Figure 22, *Aquarium*, Number 534052] In 1895, Louis Ruhe of New York City described a method of constructing an aquarium similar to that of Chilcott and Scrimgeour's 1858 design. His invention involved a system where the base portion and side plates could be detached from each other so as to be shipped in a so-called "knock-down" position, the parts being readily connected again when the aquarium was to be reassembled for use. Figure 1 is a perspective view of the aquarium. Fig. 2 is a horizontal section and Figs. 3 and 4 are respectively a horizontal and vertical section on an enlarged scale on lines 3 3 and 4 4 in Fig. 1, taken respectively through the side plates and bottom of the aquarium.

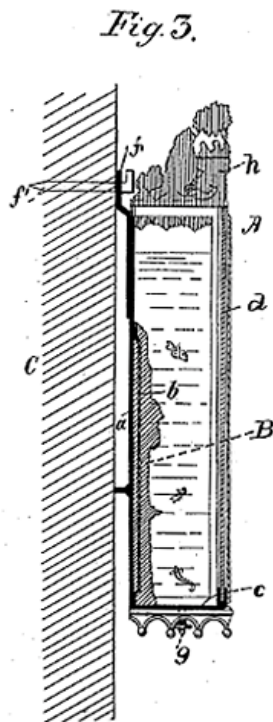

Figure 21: Ernst Lochman's picture frame aquarium, 1892.

A represents the base or bottom of the aquarium, which was formed of metal or other suitable material and supported on feet a. The glass side-plates C were connected with the base A and with each other by means of metallic angle-strips D E that were applied to the

meeting-edges of the side walls and base and of the side plates. The side plates **C** were made of glass of a suitable thickness, the angle-strips being folded and made of a corresponding size and bent at their folded edges in an outward direction, while the outwardly-extending portions or flanges **E'** formed by folding the strips were bent at an angle of approximately forty-five degrees to the main portions of the strips. The outwardly-extending flanges of the angle-strips of the side plates were connected with each other by means of bolts **e e** while the main portions **E²** of the angle-strips were provided at one of more points with eyes **e'** that were connected by means of bolts **e²** passing tightly through holes drilled through the glass side-plates so that the angle-strips were rigidly connected with each other and with the side-plates as shown in detail in Fig. 3. The bottom strips **D** were also doubled and attached by means composed of

main portions **D'** and flange portions **D²** which extended at right angles to the main portions, while bolts **d** passed through the main portions **D'** and the side plates and bolts **d'** passed through the flanges **D²** and the base **A**, as shown in Fig. 4.

For the purpose of producing the tight connection of the angle-strips **D E** with the base **A** and side plates **C** of the aquarium, elastic packing stripes **f'** were interposed between the outwardly-extending flange portions of the angle-strips **E** and similar elastic strips **f'** between the main portions of the same and the side plates, while washers were arranged at the points where the bolts passed through the side plates of the aquarium. Similar packing strips **f²** were interposed between the main portions **D'** of bottom-strips **D** and the glass plates, and between the flanges of the bottom strips and the base **A** as shown in Fig. 4. The tight-fitting of the different parts was achieved by the packing-strips. The water-tight connection of the base with the bottom-strips and of the side-plates with the corner-strips was obtained when the individual parts of the aquarium were secured together, while the bolt connection of the parts permitted the ready detaching of the parts so as to pack them into a comparatively small space for shipment. An exterior flange and two interior flanges were positioned at each corner and elastic packing strips were placed between the flanges and the glass. The assembly was held together by bolts drilled through both the flanges and the glass. The major differences in this design was that, in addition to the packing material not being heated, the flanges were made so that the aquarium could be easily disassembled for transportation and shipped in a "knock-down" position. Another improvement was that the flanges used on the bottom were securely fastened to the bottom using similar bolts.

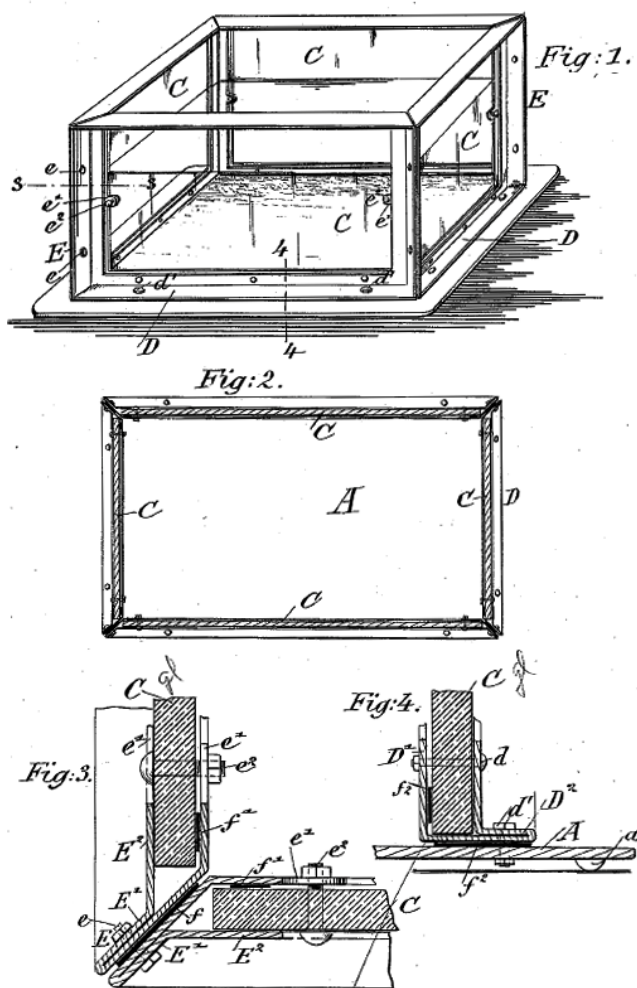

Figure 22: Louis Ruhe's aquarium construction, 1895.

[Figure 23, Aquarium, Number 460809] There were five inventions issued between 1891 and 1895 that concerned keeping the aquarium clean, all based upon the principle of removing the water at the bottom of the tank where the sediment accumulated. All of these patents were awarded to George Gunther who had patented the hanging aquarium mentioned previously. However, since his hanging aquarium

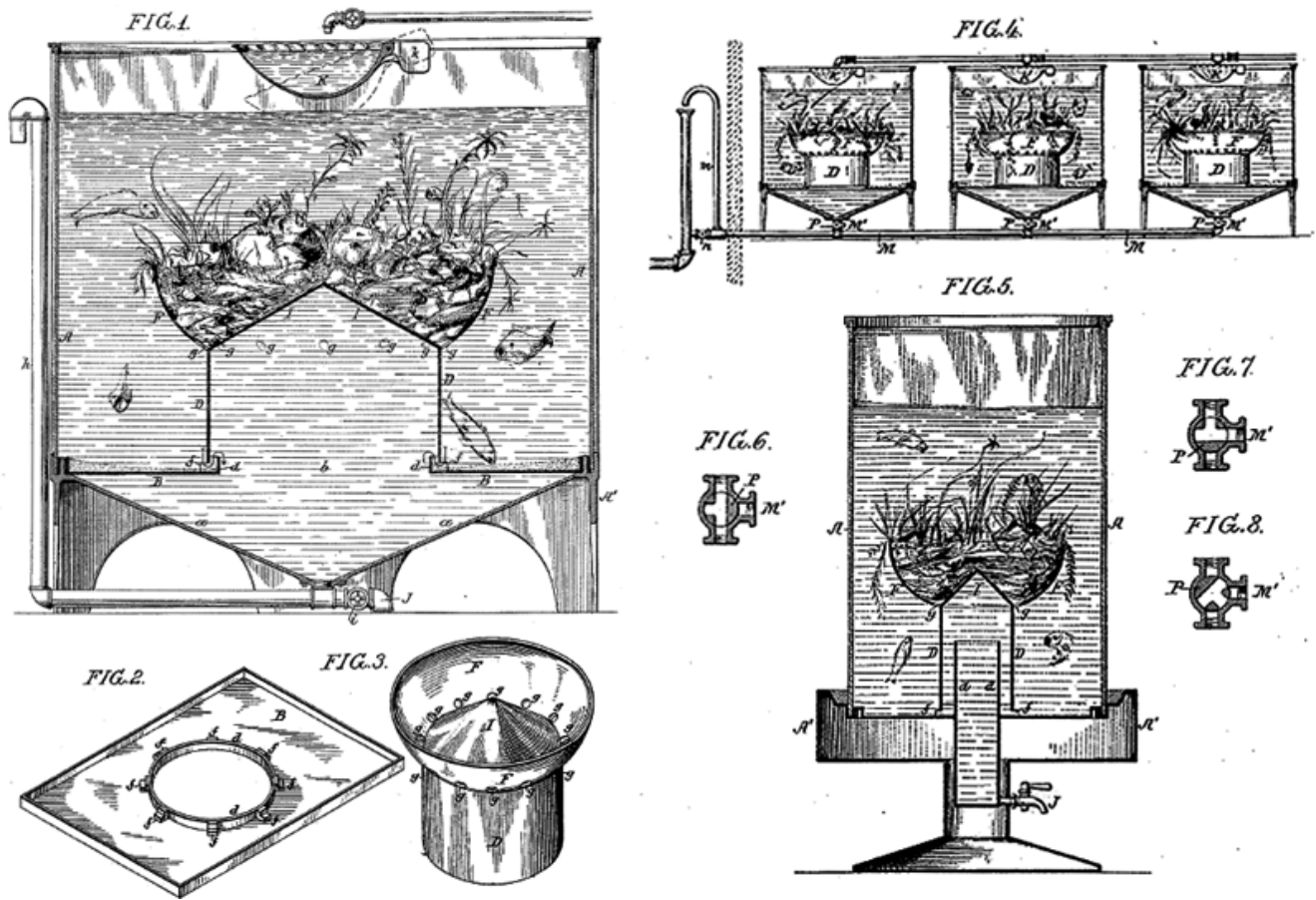

Figure 23: George Gunther's self-cleaning aquarium, 1891.

had important cleaning aspects, it might be said that aquarium cleanliness was at the heart of all of Gunther's inventions.

His first patent in this set was his design of 1891. The bottom of this tank was conical, the fish being excluded by a horizontal plate into which was placed a cylinder containing a pan with an inverted cone (the inverted cone and pan was for the placement of rockworks and plants). Sediment dropped to the horizontal plate where it passed through openings in the cylinder and then into the cone. When water was introduced at the top of the tank, the dirty water in the cone was forced out into a drainpipe. Figure 1 is a sectional view of the aquarium; Figs. 2 and 3 are detached perspective views on a smaller scale of parts of the aquarium; Fig. 4 is a view showing a series of aquariums combined and connected in accordance with the invention; Fig. 5 is a view of another form of aquarium embodying the invention and Figs. 6, 7 and 8 are detached views of the valves used in con-

nection with the series of aquariums.

In Fig. 1, **A** represented the casing of the aquarium tank, the upper portion of which was composed in whole or in part of glass. In the base **A'** of the tank was a central depression **a**, tapering to a contracted outlet at the bottom, and this depression was covered by a tray **B**, which had a central opening **b** surrounded by a wall or flange **d**. Outside of this flange **d** were a series of projecting step-like lugs **f** on which rested the cylindrical base or support **D** of a bowl or basin **F** in the bottom of which, adjacent to the cylindrical support, was a series of openings **g**. Within the basin or bowl **F** was a central conical projection or mound **I**, and around this mound and within the bowl were placed stones, rocks and aquatic plants, while in the tray **B** was a supply of sand.

The aquarium thus presented to the fish confined in it the same conditions which in their free state they would enjoy in a pool having rocky sides and a peb-

bly and sandy bottom. Hence the fish could be kept in good condition in captivity for an indefinite period, the constant changing of the water in the aquarium being effected by providing the tank with an overflow pipe **h**, communicating with the contracted outlet in the bottom of the tapering depression **a** in the base of the tank, this construction providing for a discharge of the water from the bottom of the tank as fast as fresh water was added, and a flow of water providing for the automatic cleansing of the tank in the manner of his hanging aquarium design of November 19, 1889 (Figure 20, Number 415506).

In no part of the tank did the water remain stagnant, for as the water flowed from the contracted outlet in the bottom of the tank there was a flow from the sides of the tank across the sand in the tray **B** and toward and under the lower edge of the cylindrical support **D** for the bowl **F**, the water rising inside of this cylindrical support and passing over the flange **d** and down through the central opening of the tray. Water at the same time flowed downward from the bowl through the openings **g** in the bottom, so that not only were the contents of the bowl kept clean, but fish sediment was also prevented from accumulating on the sand in the tray **B**.

The outlet at the bottom of the tank was provided with a discharge branch **J** having a suitable valve **i** on opening which the water could be drained or partially drained from the tank when desired, this flow also serving to cleanse the tank. Any sedimentary deposits upon the tapered bottom of the tank that were of such a character as to resist the mild cleansing flow caused by the overflow pipe would be dislodged and removed by the much more violent flow which resulted when the valve in the drain pipe was opened.

As in many cases the flow of water available for supplying the tank was not sufficient to cause such force in the overflow as to provide even a mild cleansing current through the tank, in the upper portion of the tank was mounted a pivoted receptacle **K** having a counterweight **h** of such character that it would almost but not quite counterbalance the weight of the receptacle and its load of water, so that when the receptacle was filled its weight would preponderate

and it would tip to discharge its contents into the tank and then resume its normal position. The discharge of this comparatively large volume of water into the tank would cause such an overflow for a short time as to insure the desired cleansing current through the tank. Where a series of aquariums was used, they were connected by means of a common pipe **M** having overflow **m** and drainage outlet so that all of the tanks could discharge through this single overflow or could be drained through this single pipe.

[Figure 24, *Fish Tank or Aquarium, Number 460810*] Combining plants and aquaria was also a fertile ground for ideas. In this same year Gunther patented an idea for an aquarium that had a removable back that contained pockets for plants. His design was a bit more complicated than his previous one, however, in that behind the plant wall was a space that communicated with a V-shaped chamber at the back of the tank. The chamber had a drainpipe that led to a collecting vessel at the front of the aquarium. When new water was added to the tank, the older water flowed under the plant wall to the top of the tank and spilled over into the V-shaped chamber. The V-shape served to concentrate the sediment that then was discharged to the front collecting vessel. Figure 1 is a perspective view of one form of an aquarium illustrating the invention. Fig. 2 is a transverse section of the same, Fig. 3 is a rear view on a somewhat smaller scale, Fig. 4 is a perspective view of another form of aquarium embodying the invention and Fig. 5 is a transverse section of the same.

The aquarium was of quadrangular form and had in its front portion a plate **B** of glass so as to permit free inspection of the contents of the vessel. On the rear wall **a** of the vessel a pocket **D** was formed that tapered from top to bottom, being widest at the top and narrowest at the bottom where it communicated with a contracted discharge passage **b** leading through the bottom of the vessel to an outlet nozzle **d** at the front. The rear wall **a** of the vessel was discontinued some distance below the top so as to provide an overflow communicating with the chamber or passage within the rear pocket **D**, the tapering of this pocket serving to concentrate the volume of overflow as it descend-

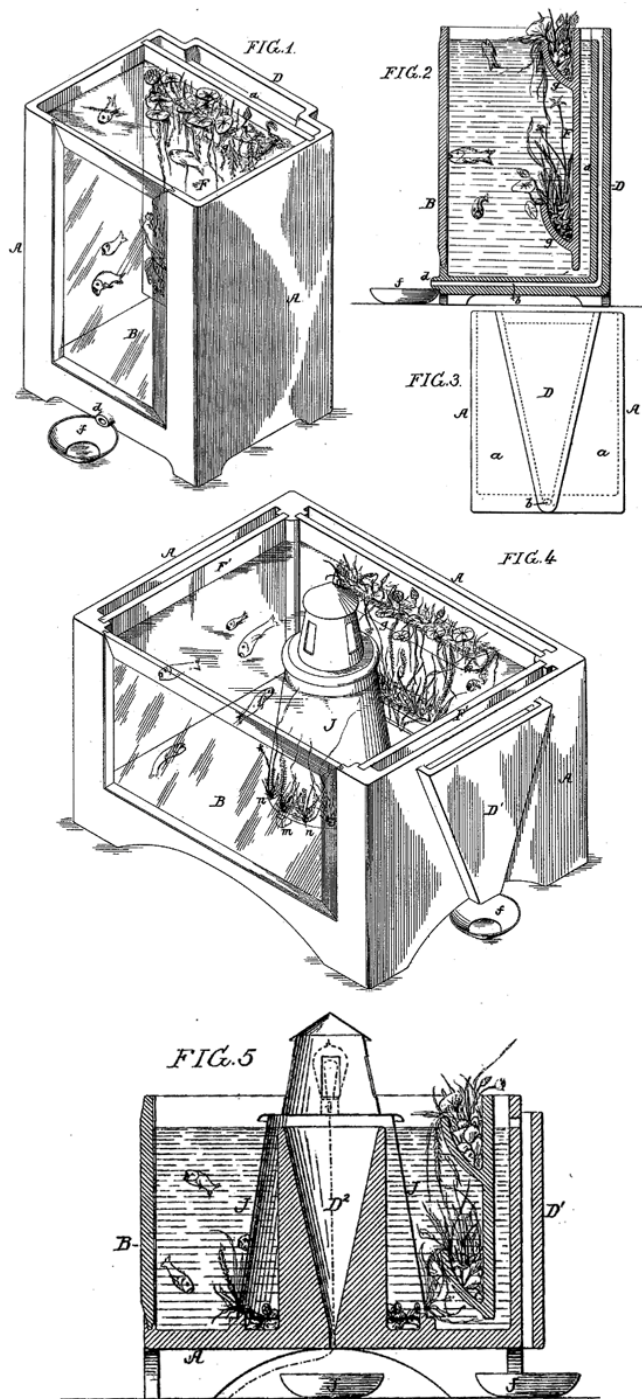

Figure 24: George Gunther's sediment collector and plant rack aquarium, 1891.

ed so that even if the volume of the overflow was but slight it would by the time it reached the bottom of the pocket and the discharge passage **b** fill the latter and will have acquired such velocity of flow as to effectually prevent the collection of sediment in the passage. Moreover, the contraction of the passage **b**

permitted the discharge of the overflow into a receptacle of small dimensions and prevented the slopping or drip that would result if the outlet passage was of extended area and the flow through the same was sluggish.

Some little distance in advance of the back wall **a** of the vessel the sides of the latter were grooved for the reception of the edges of a slab or plate **F** that extended from the top of the vessel or from a point above the overflow line down to a point close to the bottom of the vessel. Hence water in seeking the overflow had to pass beneath this slab, which practically formed a false back for the vessel. The discharge current was therefore always from the bottom of the vessel and tended to carry up with it sediment that may have collected on the bottom.

On the face of the slab **F** were pockets or receptacles **g** that were intended for stones and aquatic plants, the lower receptacle having the plants that usually grow at the bottoms of streams or ponds, while the upper receptacle carried the plants which usually grow at or near the surface. The vessel **A** could conveniently be formed of glass or earthenware in one piece. The front glass **B** and false wall **F** could be readily slipped into place so that the vessel provided an attractive form of aquarium that could be constructed more cheaply than the built-up aquariums sometimes employed in those days.

In Figs. 4 and 5 is shown another form the aquarium having false walls **F'** at the back and at both sides and having discharge pockets **D'** at the back and at both sides, the overflow openings being formed in the outer walls of the vessel some distance below the top of the same, the tapering form of the discharge pocket being preserved for the reasons given previously. In this case there was also a central discharge or overflow in the form of a cylinder rising from the bottom of the vessel and tapered internally with a contracted outlet at the bottom. This central overflow was hidden from view by a surrounding structure **J** that was in the patent in the form of a lighthouse, but which represented any structure of an ornamental character. This outer casing could, if desired, have in the upper portion an electric lamp as shown by dot-

ted lines in Fig. 5, the wires from the lamp extending down through the central overflow passage.

[Figure 25, *Fish-Tank or Aquarium, Number 475082*] Another of Gunther's self-cleaning aquariums, patented in 1892, involved using water to generate a specific flow pattern that would drive the sediment to troughs where it would build up and be removed. Figure 1 is a sectional perspective view of a portion of an aquarium and Fig. 2 is a transverse section. Fig. 3 is a sectional view of a modified form of the aquarium and Fig. 4 is an enlarged section of part of the aquarium shown in Figs. 1 and 2.

In Figs. 1 and 2, **A** represented the foundation of the aquarium and **B** the containing structure mounted thereon and having its walls composed of sheets or plates of glass, the bottom of the tank having sloping sides and a narrow flat bottom from which near the center rise two low ribs or flanges **a** that in connection with tiles or slabs **b** resting on support blocks **d** raised above the tops of these ribs, form a central discharge passage **f** communicating with a discharge pipe **g**, extending through an arched vault formed in the foundation.

Along each side of the tank close to the bottom extended a pipe **D** that was perforated on its inner side so that water under pressure admitted to the pipe was discharged downwardly along the sloping bottom of the tank and toward the inlets into the discharge-passage **f** so as to wash the fish slime or sediment into the passage and prevent it from accumulating on the bottom of the tank. To provide for the withdrawal of the deposits from the discharge passage **f** there was a steady and continuous flow of water therefrom, which was insured by means of a valve at the discharge end of the pipe **g**. This was accomplished by connecting the pipe to one or more branch pipes **i** extending up to the desired level of water in the tank so as to serve as overflow pipes and thus provide for a steady and continuous discharge of water from the passage **f** in accordance with the volume of fresh water introduced into the tank. The pipes **D** could serve as the sole means for supplying the fresh water or there could, if desired, be an additional supply discharged into the top of the tank, the main purpose of the pipes **D** in this case being to act as a cleansing device.

[Figure 26, *Fish-Tank or Aquarium, Number 546882*] Perhaps the most interesting of all Gun-

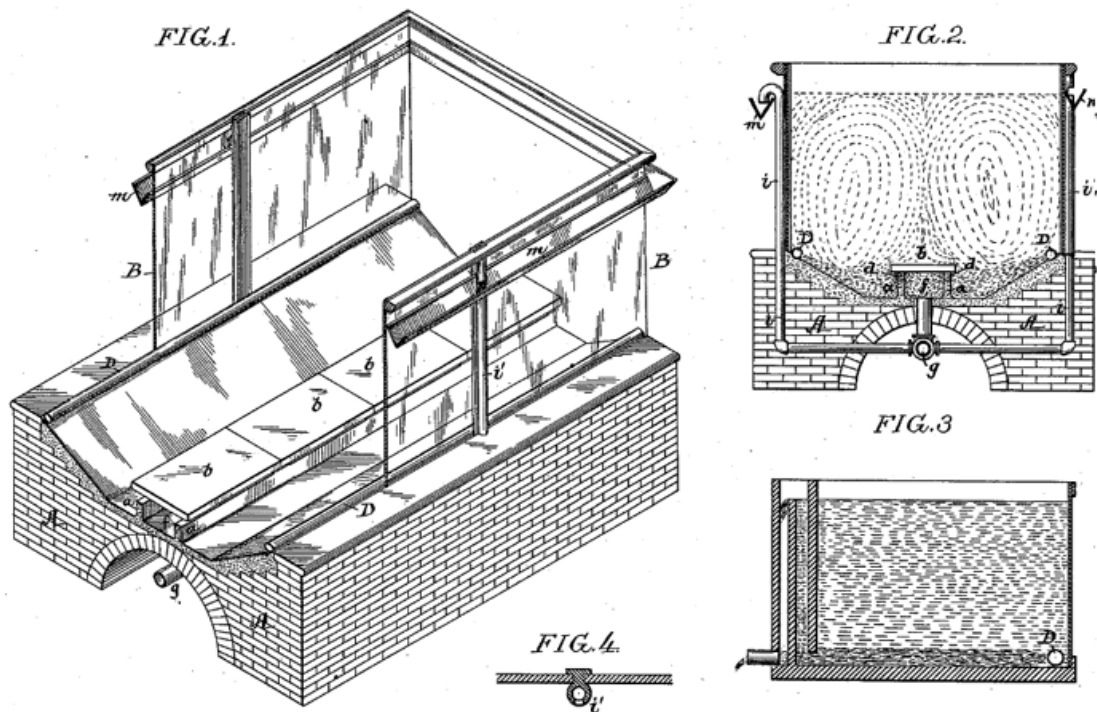

Figure 25: George Gunther's sediment collection design, 1892.

ther's variations on this theme was his 1895 patent that incorporated a false bottom in the tank. The false bottom was smaller than the real bottom, allowing water with sediment to accumulate under it. The false bottom contained a tube capped at the end at the water surface and within it was an overflow tube open at its end under this tube. Whenever freshwater was added to the tank, water – with its sediment – would flow from under the false bottom up and into the overflow tube where it was carried away. Gunther was aware that fish tanks had been constructed with duplex overflow pipes communicating with the tank at or near the bottom and did not broadly claim such construction since his approach was devised with the view of inducing a current in all parts of the tank and providing a simple and convenient means whereby ordinary fish tanks having the usual top overflow could be readily converted into tanks with a bottom outlet, the bottom outlet being so placed around the tank as to cause a drainage current in all directions when the overflow was in operation. When one thinks about it, Gunther had very nearly invented the undergravel filter... close but no cigar!

Figure 1 is a longitudinal sectional view of an ordinary form of fish tank or aquarium, and Fig. 2 is a perspective view.

A represents the base of the tank and **B** the glass sides. The tank had at one end an overflow-pipe **a** extending up to the desired level. Within the tank and a short distance above the bottom was a false bottom **D** that consisted of a plate of the same or substantially the same contour as the tank but slightly less in dimensions than the interior of the tank so as to form a passage all-round the false bottom between the edges and the sides of the tank.

The false bottom **D** was supported at the desired height above the base of the tank by means of feet or by projections formed either upon the false bottom or upon the base. The false bottom had near one end a tube **b** open at the bottom and also by preference at the top, this tube being somewhat larger in diameter than the overflow-pipe **a** and of such height as to project slightly above the top of the overflow pipe as shown in Fig. 1. Whenever fresh water was added to the tank therefore, the overflow water found its way around the edges of the false bottom **D** and through the space between the false bottom and the base of the tank and rose between the overflow pipe **a** and the tube **b**. A current was thus created over the entire surface of the false bottom **D**. Consequently any fish slime or sediment that was deposited upon it was likely to be swept away by such current so that the tank was kept reasonably clean and any objectionable accumulations upon the bottom were prevented. The plate **D** and its tube could be ornamented in various ways and the location of the tube upon the plate changed to accord with any change in the position of the overflow pipe in the tank.

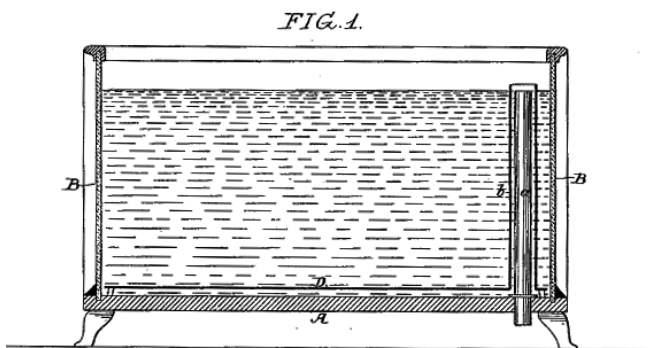
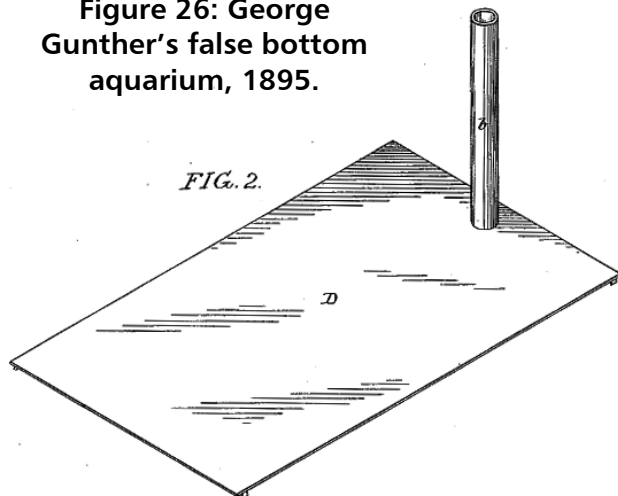

Figure 26: George Gunther's false bottom aquarium, 1895.



[Figure 27, *Fish-Tank or Aquarium*, Number 546883] Gunther's last invention, also awarded in 1895, was probably his most ingenious. Water exited the aquarium through a pipe at the bottom into a vessel, **A**, containing a filter shown in the inset. A box (**B**) was situated around the ascending pipe that led from **A**, the purpose of which was to hold ice water to cool the water in the aquarium if it became too warm. At the end of the pipe was a pump barrel that

extended over the tank, the other end being connected via a lever to a series of gears powered by a weight, an engine similar to the one used in Sandford's 1880 elevator aquarium. However, Gunther also specified that either a spring or electrically-drive motor could be used for this purpose. Figure 1 is a perspective view of an aquarium and attachments and Fig. 2 is an enlarged sectional view of a combined filter and sediment collector constituting one of the attachments.

A represents an aquarium, which may be of any suitable construction and of any desired size and shape, being preferably mounted on the table **B** or being itself provided with supporting legs or feet so as to maintain the body of water contained in it at a considerable level above the floor. The aquarium discharged at a point near one corner of the bottom through a pipe **a** that communicated with the bottom of a vessel **D** suitably mounted below and at one side of the aquarium. This vessel had in its upper portion a filter of any desired character, that shown in the drawings being a cup **b** packed with appropriate filtering material and

having a perforated bottom. The cup had a top flange **d** resting upon an internally- projecting rib **f** in the vessel **D** so that it could be readily removed for cleansing or refilling when desired, the top of the vessel being closed by a detachable screw-cap **g**. The lower portion of the vessel **D** had a cock or faucet **h** through which the contents of the vessel and if desired, also the water in the aquarium **A** can be drawn off, although it was preferable to provide the pipe **a** with a valve **a'** in order to cut off the connection between the aquarium **A** and the vessel **D** when desired. From the cap **g** of the vessel **D** a pipe **i** extended upward through a box **F** suitably supported at one side of the aquarium and adapted for the reception of ice in order to cool the water ascending in the pipe **i**, the latter terminating above the level of water in the aquarium **A** so that the water stood at the same level both in the pipe and in the aquarium.

Projecting into the upper end of the pipe **i** and extending downwardly into the same to a point below the level of the water was a pump-barrel **m** having a discharge-spout **m'** extending over the aquarium **A** at the corner diagonally opposite that into which the outlet communicated. The plunger of the pump **m** was connected to one arm of a lever **n**, the other arm of which was connected to a crank-pin on a wheel that was rotated in any suitable manner. The wheel formed one of a train of gears **p** to which motion was imparted by means of a suspended weight **p'** but a spring or electrically driven motor could be employed for operating the pump.

When the pump was in operation, there was a constant flow of water from the aquarium through the pipe **a**, vessel **D** and pipe **i**, and thence through the pump back into the aquarium, the rate of flow being dependent upon the speed at which the pump was driven and upon the capacity of the pump. Gunther used a pump of small capacity so that there was a slow but steady withdrawal of the water from the aquarium, the flow not being sufficiently rapid to cause any material disturbance of the body of water in the vessel **D**, so that the fish-slime and other solid impurities held in suspension in the water would settle to the bottom of the vessel before reaching the filter **b**, the latter serving to separate the remaining

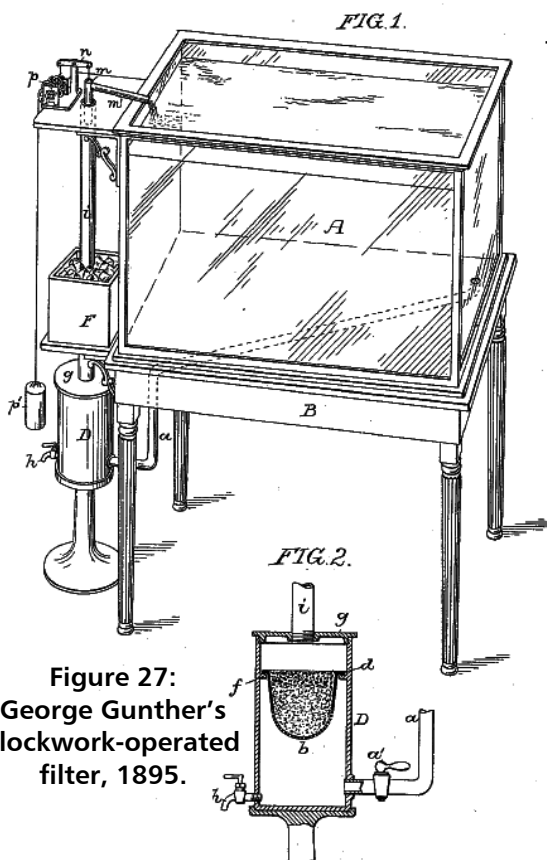

Figure 27:
George Gunther's
clockwork-operated
filter, 1895.



THE PRESIDENCY OF THEODORE ROOSEVELT: THE DECADE OF 1899-1908

[Figure 30, *Incubator for Fish*, Number 680838]
 The first U.S. patent for a breeding trap was awarded in 1901 to Henry Bourgeois of Tourouvre, France. The device contained a movable grid of glass rods so that the fry could escape below, but it also incorporated a plate (half of which was perforated) at one end that admitted fresh water. If eggs were to be placed on the rods, then the plate was positioned with the holes on the topside so that the current flowed over the eggs. When the fry hatched, the position of the plate was reversed with the holes on the downside so now fresh water circulated at the bottom, providing them with a constant change of water. Figure 1 is a longitudinal section of the incubator, Fig. 2 is a plan view, Fig. 3 is a cross-section through line X Y in Fig. 2 and Fig. 4 is a longitudinal section showing the grid removed and the position of the movable vertical plate when the fry have been hatched.

The tank or casing **a** was provided with a water inlet **b** and an outlet or overflow **c**. The movable grid consisted of a number of glass rods **e** being attached to a frame **d** in any suitable manner, the grid being supported upon the projections **f** or the like. The movable vertical plate **g** was carried in grooves or the like in the sides of the tank or casing **a**, about one-half of its area being provided with suitable perforations **h** as shown in Fig. 3. Referring to Figs. 1, 2 and 3, the eggs were placed upon the grid and plate **g** was placed in the position shown so that the perforated part was uppermost and a constant supply of water was allowed to enter the tank or casing at the inlet **b**. The stream or current of water would flow in a direction as shown by the arrows in Fig. 1, passing between the glass rods and so circulating the eggs with a constant change of water. Referring to Fig. 4, upon the fry being hatched they fell to the bottom of the

tank. The grid was then removed and the position of the plate **g** reversed as shown, causing the stream or

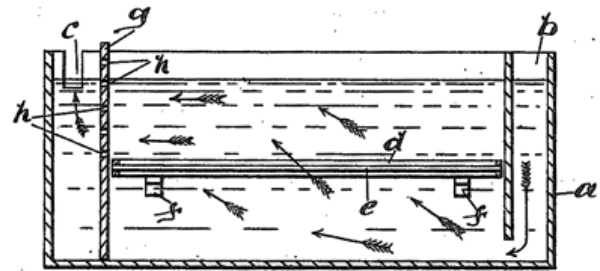

Fig. 1.

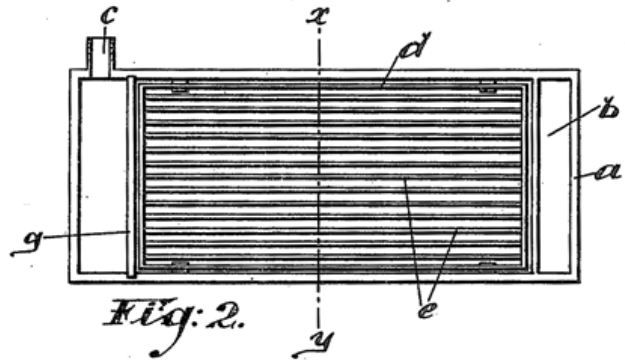

Fig. 2.

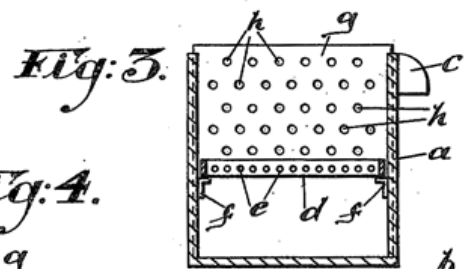

Fig. 3.

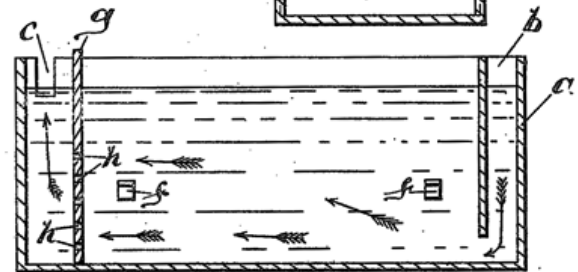

Figure 30: Henry Bourgeois's breeding trap and haven for small fishes, 1901.

current of water to flow in a direction as shown by the arrows, thus giving the fry a constant change of fresh water.

[Figure 31, *Aquarium, Number 649494*] Several patents for cleaning an aquarium were awarded during this decade, the first of which was conceived in 1900 by George W. Sues of Omaha, Nebraska. A variation of the settling technique, Sues' aquarium had two end panels of the aquarium (made from any suitable material, a scrolled design being shown in the Figure) separated by two pieces of glass (held

together by tie rods) and angled so that they met at a V at the bottom. The sediment gravitated to the bottom where it was removed by a draw-off valve.

Figure 1 is a central sectional view of an aquarium embodying the invention with portions broken away, Fig. 2 shows a side elevation with portions broken away, Fig. 3 shows an enlarged broken detached detail disclosing the relative position of the pipe and projecting ribs, Fig. 4 shows a sectional top view with portions removed, while Fig. 5 shows a slight modification in which the outer supporting-ribs are shown as united.

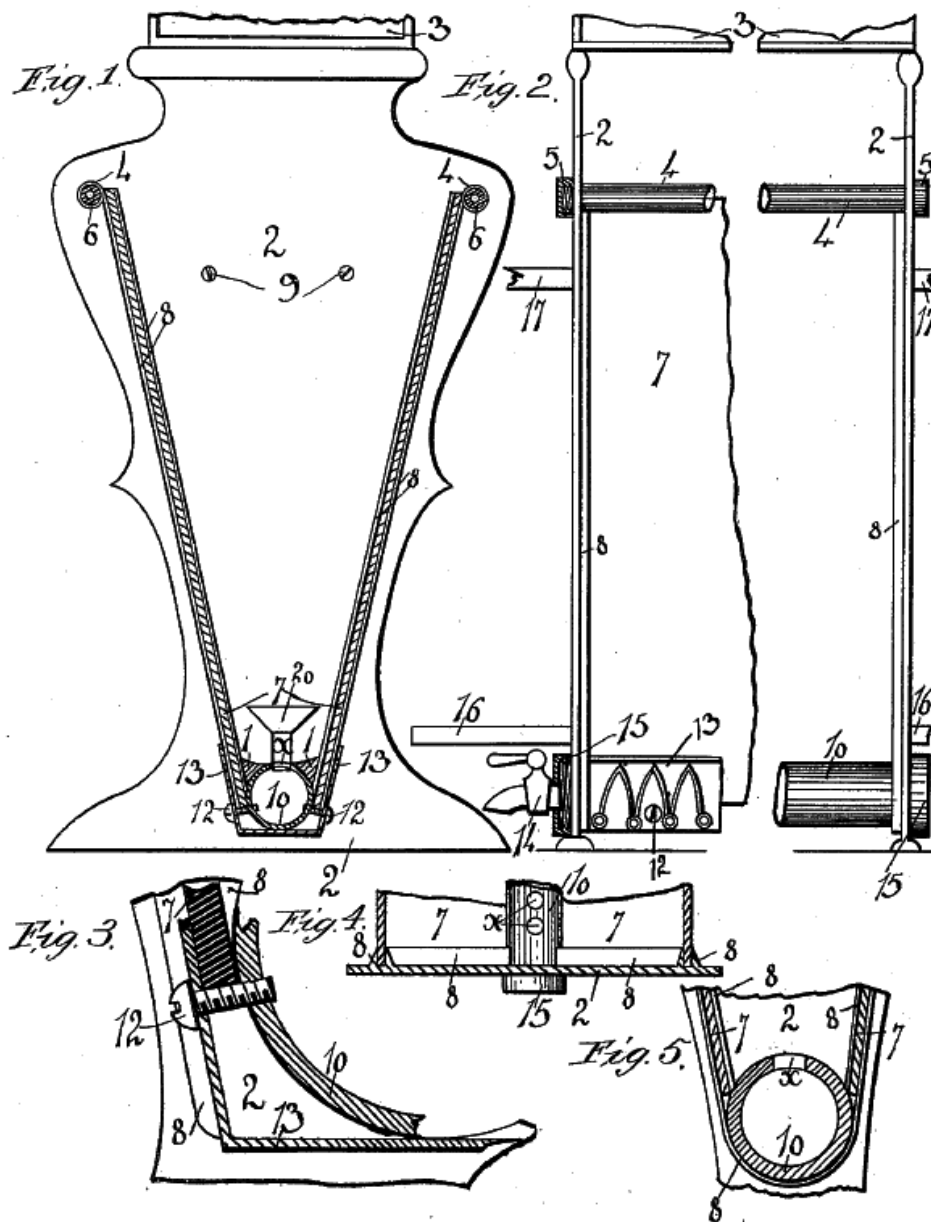

There were two similar end panels 2 of any desired width or material and that could be given an artistic shape in outline as well as having both the inner and outer surfaces suitably embellished. These panels were used in sets of twos and form the ends of the aquarium, while two glass sheets or panes 7 formed the sides, the perforated pipe 10 serving as the bottom for the aquarium. In Fig. 1 it shows that the glass plates 7 7 were held in a V-shape between suitable ribs 8 8 that were made an integral part of the panel. These panels, made either in sheet or cast metal or any other suitable material, were further provided with two openings near the upper end and adjacent to the termination of the ribs 8, while a third larger opening was placed within the lower end of the panel at a point between the two inner ribs.

The bottom of the aquarium comprised a pipe 10 of a

Figure 31: George W. Sues' Sediment settling design, 1900.

length exceeding the length of the glass plates 7 and the combined thickness of the two panels 2, and was provided with an aligned series of perforations x, as is shown in Fig. 4. It had its ends threaded, as shown in Fig. 2, to receive the end caps 15 15. This tube 10 fitted snugly within the lower portion of the panel and acted as a stay-rod in uniting the two end panels 2 at their lower ends in conjunction with the caps 15. At the upper ends there were two pipes 6 which could be provided with embellished casings 4 which united the panels at the upper ends, these pipes being threaded at each end and adapted to receive the ordinary caps 5 as is shown in Fig. 2. These pipes were so positioned that when the glass plates were inserted the plates terminate adjacent to the tube 10 as is shown in Fig. 1 and rested against the pipes 6. The aquarium embodied essentially two end panels, two glass plates, a bottom drain-pipe acting as a stay-rod, and two upper connecting-pipes.

As the bottom of the aquarium was very much narrower than the top, all the impurities naturally gravitated toward the narrow bottom and either immediately fell through the openings x into the drain chamber, pipe 10 or collect upon the bottom of the aquarium which was made to slope toward the openings, as is shown in Fig. 1. The fish as they sought their food naturally swam to the bottom of the aquarium and there agitated the water so that all heavier particles that had collected there were agitated until they came over one of the openings x, so that the fish actually appeared to sweep the bottom of their aquarium to precipitate the impurities into the basement or drain-chamber in communication with the aquarium.

There was further provided a very narrow sheet of water, but this sheet was correspondingly deep so that the fish could always be seen and the plant life within the aquarium could be studied as everything was brought so clearly into view. The sides formed by the two glass plates being at an angle further provided a prismatic effect, which was very novel and added to the attractiveness of the aquarium. In order to drain the aquarium, the drain-tube was provided at a suitable point with an ordinary water-cock 14 that was made large enough so that when it was opened the water rapidly swept through the drain-tube and so car-

ried out all the collected impurities. This cock, however, was not absolutely necessary, as the drain-tube could be easily emptied by the ordinary siphon method. By means of this peculiarly-constructed aquarium, the water was continually kept clean and free of impurities, while the humus, so destructive to fish life, could be instantly removed. A further advantage was that in cleaning the bottom of the aquarium the fish were not disturbed in any way and their scales were not injured or the delicate fins torn, which was quite essential when paradise fish and Japanese fan and fringe tails were in the aquarium.

[Figure 32, *Fish Globe or Tank*, Number 634626] An interesting patent was awarded in 1889 () to Albert J. Park of Worcester, Maine that incorporated the set-

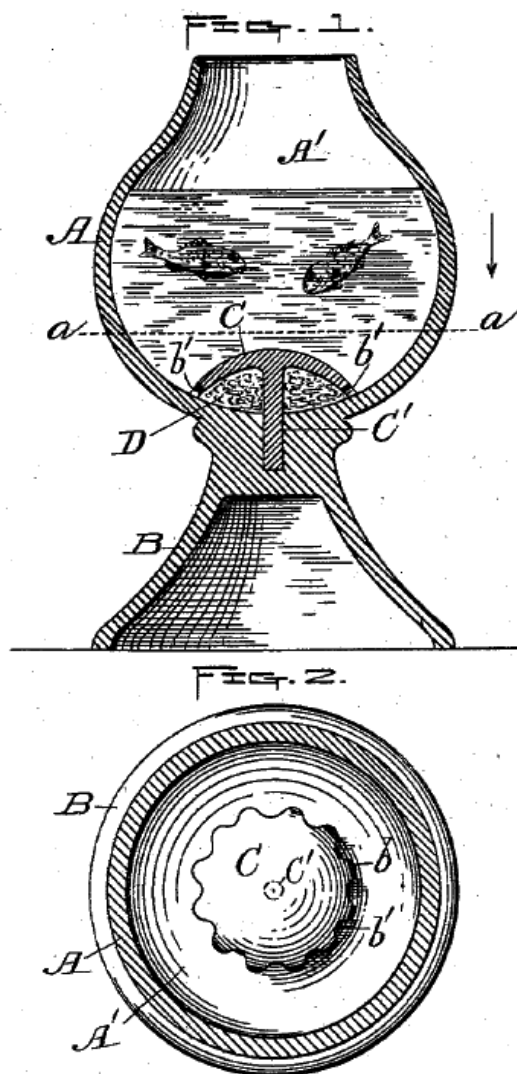

Figure 32: Albert J. Park's sediment settling globe, 1899.

tling technique into the typical fish globe of the time. This involved placing a horizontal partition in the bottom of the globe somewhat similar to Gunther's false bottom patent of 1895. The partition left enough room along its sides for sediment to collect at the bottom of the globe. Once the sediment accumulated at the bottom, the partition prevented sediment from being drawn up again into the globe. Figure 1 represents a central vertical section through a fish globe with the improvements applied and Fig. 2 is a horizontal section taken at the point indicated byline **a - a** in Fig. 1, looking down and showing a plan of the bottom of the globe where the improvements were applied.

C is a horizontal partition arranged across the inside of the globe near the bottom to form the refuse chamber or receptacle **I** underneath between it and the bottom of the globe. The partition could be formed in various ways and of different shapes and not limited to any special way of producing it or to its special shape or size. It was made separable from the globe and similar in shape to an ordinary mush-

room or toadstool, with a central downwardly-projecting stem **C'**, which was fitted in a vertical opening formed in the bottom of the globe to hold it in position and with a scalloped edge **b** to form openings **b'** around it next to the wall of the globe for connecting the upper or main globe chamber **A'** with the auxiliary refuse chamber **D**. By thus providing the globe or other receptacle with an auxiliary chamber at the bottom connected by openings, with the upper main chamber the fish deposits and other particles or impurities in the water settling to the bottom worked down through the openings **b'** and collected in the auxiliary chamber **D** as shown in Fig. 1. The refuse matter, after thus passing into the auxiliary chamber being covered by the horizontal partition, was not liable to work up again into the upper main chamber, and consequently the water was always kept clean and clear.

[Figure 33, *Fish Globe or Tank*, Number 880783] In the 1908 water regeneration scheme of Georg Erlwein and Ernst Marquardt of Berlin, Germany (), water was drawn from the tank and taken to a reser-

Figure 33: Georg Erlwein and Ernst Marquardt's water regenerator, 1908.

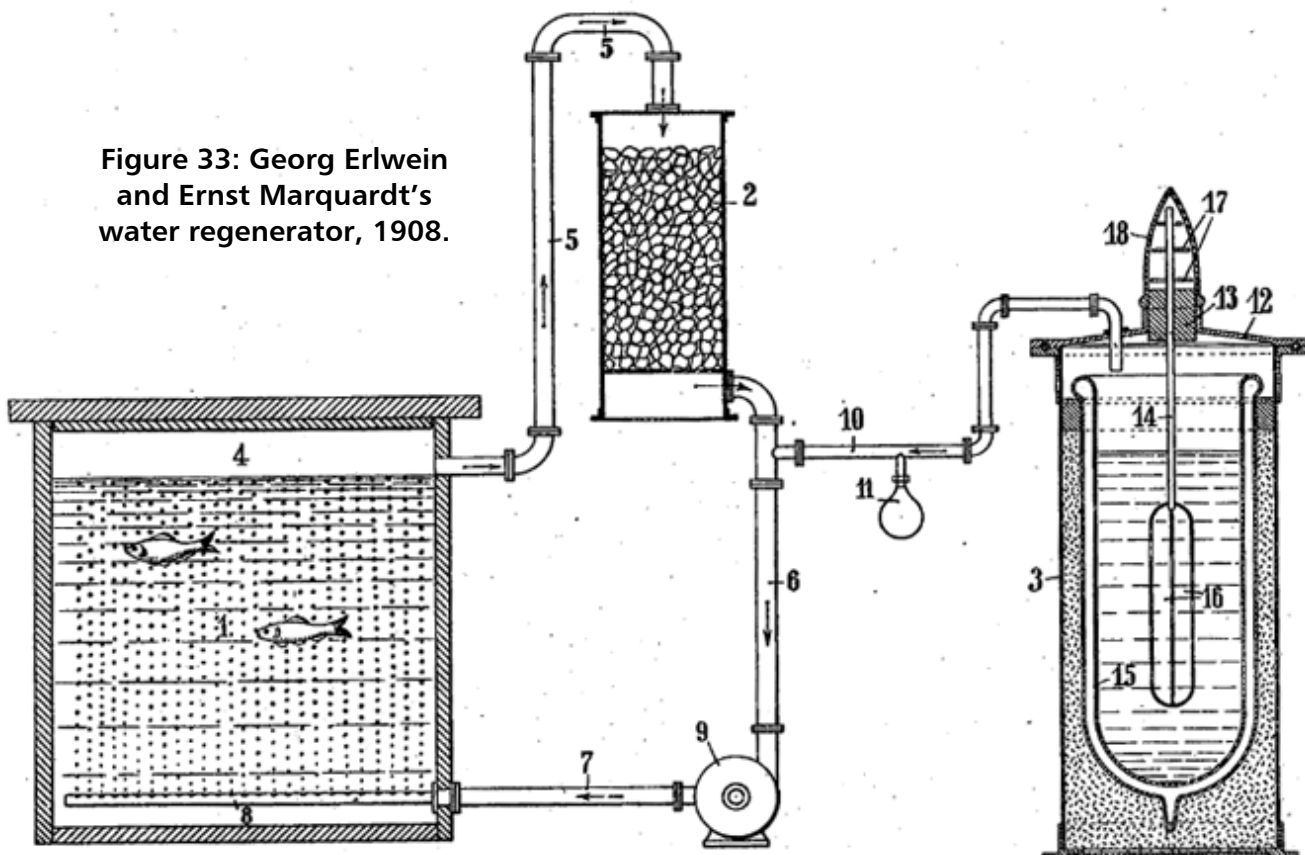

voir filled with lime where carbon dioxide was removed. The water was sent back to the tank using a motor, and along the way air or oxygen was added from the apparatus shown in the Figure.

1 was the aquarium closed by a lid, **2** was an apparatus for absorbing carbonic acid filled for instance with lime and **3** was a supply source for oxygen, which could be liquefied oxygen or liquefied atmospheric air. The upper space of the apparatus **2** for absorbing carbonic acid was connected with the air space of the reservoir **1** by a pipe **5**, while from the lower space of the apparatus **2** for absorbing carbonic acid a conduit of pipes **6, 7** lead to the lower part of the reservoir **1**. Part **8** of this conduit of pipes was provided with holes; between the pipes **6** and **7** was placed a pump **9**. The supply source **3** for the oxygen was connected with the pipe **6** through a pipe **10**, into which is placed a pressure regulator **11**.

While the water remained in the reservoir **1** the air under the action of the pump **9** made the following circular course: From the space **4** of the reservoir **1** the air charged with carbonic acid was conducted through the pipe **5** into the upper part of the apparatus **2** for the absorption of carbonic acid. It gave off the carbonic acid to the absorbing medium (for instance lime) and entered freed from carbonic acid into the pipe **6**, to which is also conducted fresh oxygen from the supply source **3** through the pipe **10**. The air freed from the carbonic acid and enriched with fresh oxygen finally passed through the pipe **7** into the pipe **8** provided with holes, ascended through the holes pipe **8** in the reservoir and, charged with carbonic acid, repeated the circular course and so on.

The supply source **3** for the oxygen was formed as follows. **3** was an airtight, closed metal cylinder lined with an insulating mass through whose lid **12** passed and reached down into the evaporating-vessel **15** filled with liquid gas. A rod, tube or wire **14** or the like was held by a stopper **13**. The rod **14** was made of a good heat-conducting material such as metal. The metal rod **14**, in order to enlarge its surfaces, could be provided at both ends with ribs **16** and **17**. The upper end with the ribs **17** could be pro-

ected by a hood **18** of glass or any other suitable material.

[**Figure 34, Automatic Aquarium and Flushing Device, Number 867112**] Mark Connor, a British subject living in the city of Los Angeles, patented in 1907 a novel device to automatically renew and replenish the water in an aquarium. Although it looks complicated, it is actually quite simple. The long pipe that enters at the bottom of the tank and extending some distance above it is a water supply pipe. The two horizontal attachments at the top are plates over which the water flows, much like a cascading fountain. The shorter pipe to the right of the longer one is the outlet pipe. At its top is a siphon chamber that maintains a constant water level in the aquarium. The main object of the invention was to "... provide an aquarium in which the water will be automatically renewed or replenished so that so that it will always be fresh." By providing the plates on the inlet pipe, the entering water was aerated and had a chance to adjust to the temperature of the aquarium water so that the fish would not be subject to an abrupt change.

Figure 1 is a vertical section of one form of the aquarium, Fig. 2 is a detail horizontal section on line $x^2 - x^2$ in Fig. 1 and Fig. 3 is a detail vertical section of a modified form of the lower water seal. Fig. 4 is a horizontal section on line $x^4 - x^4$ in Fig. 3, Fig. 5 is a vertical section of another form of said water seal, Fig. 6 is a horizontal section on line $x^6 - x^6$, in Fig. 5, Fig. 7 is a side elevation of another form of the aquarium and Fig. 8 is a detail section of another form of the siphon device.

The operation was as follows. Valve **6** was opened, allowing water to flow through pipe **2**, the water falling from the outlet at the top of the pipe and falling over the tables **3**. As the tank filled, the water would rise in pipe **11** and would eventually reach chamber **13** and flow over the wall surrounding chamber **15**. Enough would run down pipe **10** to fill the seal cup **19**. The funnel **16** at top of chamber **15** acted to restrain the flow of water into pipe **10** and to enable the air to pipe to be compressed by the incoming water without forcing its way back into chamber **15**.

Water would then continue to flow into chamber 13 until the air therein was sufficiently compressed to cause it to force its way out through the seal at 19, thereby allowing the siphon to fill with water. The water would be siphoned off from the tank until the level reached the hole 9. Air would then enter the hole to break the siphon and the siphon would be emptied. Then as the water continued to flow into the tank, the above described operation was repeated, except that the water seal at 19 was now already filled ready for operation.

The device could be modified in various ways. Thus, the water seal chamber and cup could be round as indicated at 18 and 19 the cup being supported by radial webs 22 in Fig. 2 or the chamber could be elongated as shown at 18 and 19 in Figs. 3 and 4. The cup could be formed thereon or by a wall 23 in the seal chamber 18'' as shown in Figs. 5 and 6. The tank could be of any desired form. It could be cylindrical as in Fig. 1 or more or less globe shaped as shown at 1' in Fig. 7. In the last named figure the outflow pipe 11 was off to one side instead of around the inlet pipe 2. A valve 25 could be provided for the outlet pipe 7 as shown. The pipe 11 could either open directly into the tank adjacent to the bottom as shown in Fig. 7 or it could extend as in the above into a cup 12 which would prevent undue suction into the pipe. This would be especially desirable in case of fish hatching aquariums, as this cup would decrease the liability of small fish being drawn into the waste pipe. To further safeguard against this a wire gauze screen or strainer could be arranged over the cup as shown at 27 in Fig. 1. The hood 17 in the siphon chamber 13 could be omitted, as shown in Fig. 8.

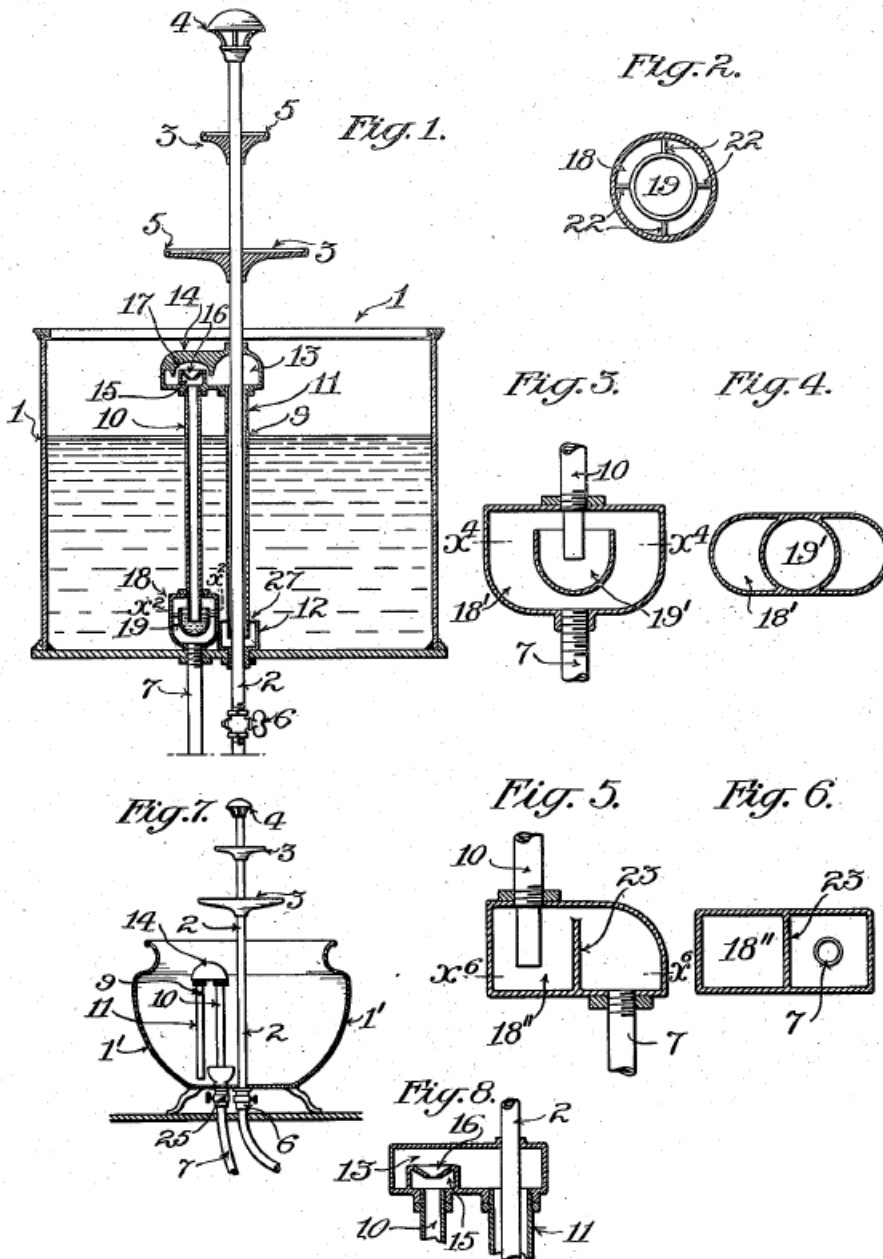

Figure 34: Mark Connor's Automatic Aquarium and Flushing Device, 1907.

[Figure 35, *Aquarium Attachment*, Number 894056] In 1908 Henry Austin Rogers of Pagosa Junction, Colorado patented an interesting variation on the air lift. The air came from a cylinder filled manually using a hand pump. The air/water mixture was returned to the tank above the water level, thus increasing the aeration. The water ultimately emptied into a floating strainer that served as a small filter. Figure 1 is a perspective view of an aquarium fitted with the device; Fig. 2 is an enlarged vertical section through

the aquarium and the applied attachment; Fig. 3 is a vertical section through the filter employed; and Fig. 4 is an enlarged sectional view of the water feeding column and its connected air supply and water drip pipe.

Within the aquarium A a standpipe B was located, being secured to the bottom of the aquarium in any desired manner. The chamber 10 of the standpipe was provided at its lower end with a branch pipe 11

that was in communication with the water at the bottom portion of the aquarium. The top of the standpipe B was below the level of the water contained in the aquarium. The standpipe was provided at its upper end with two longitudinal chambers 12 and 13 that were parallel and separated by a partition 14, but both of the chambers had a connection to the main chamber 10 of the stand pipe, as illustrated at 15 in Fig. 4. The chamber 12 was adapted to receive the delivery end of an air supply pipe 16, while the chamber 13 at its upper end 65 received the inlet end of a combined water and air discharge pipe 17. The pipe 17, and in fact all of the pipes with the exception of the air supply pipe 16, were of glass.

The discharge pipe 17 extended above the level of the water, usually with more or less of an upward inclination and at its upper end was bent downward so as to lie over a floatable strainer C. The strainer C, as is shown particularly in Fig. 3, consisted of a body section 18 circular in cross section and rounded at the bottom, being provided at its bottom portion with suitable apertures 19. The upper portion of the body of the strainer was made to flare outward so as to be more or less funnel-shaped, for the purpose of presenting a large area to the discharge pipe and so that as the strainer floated, the drops of water striking the flare would change the direction of the strainer and prevent it from floating from under the discharge pipe. The strainer was provided with an annular air chamber 21 formed exteriorly on the body for the purpose of floating it. Air could be supplied to the pipe 16 from any suitable form of apparatus. When the air was so supplied from the pipe 16 and the

Figure 35:
Henry Austin Rogers'
airlift, 1908.

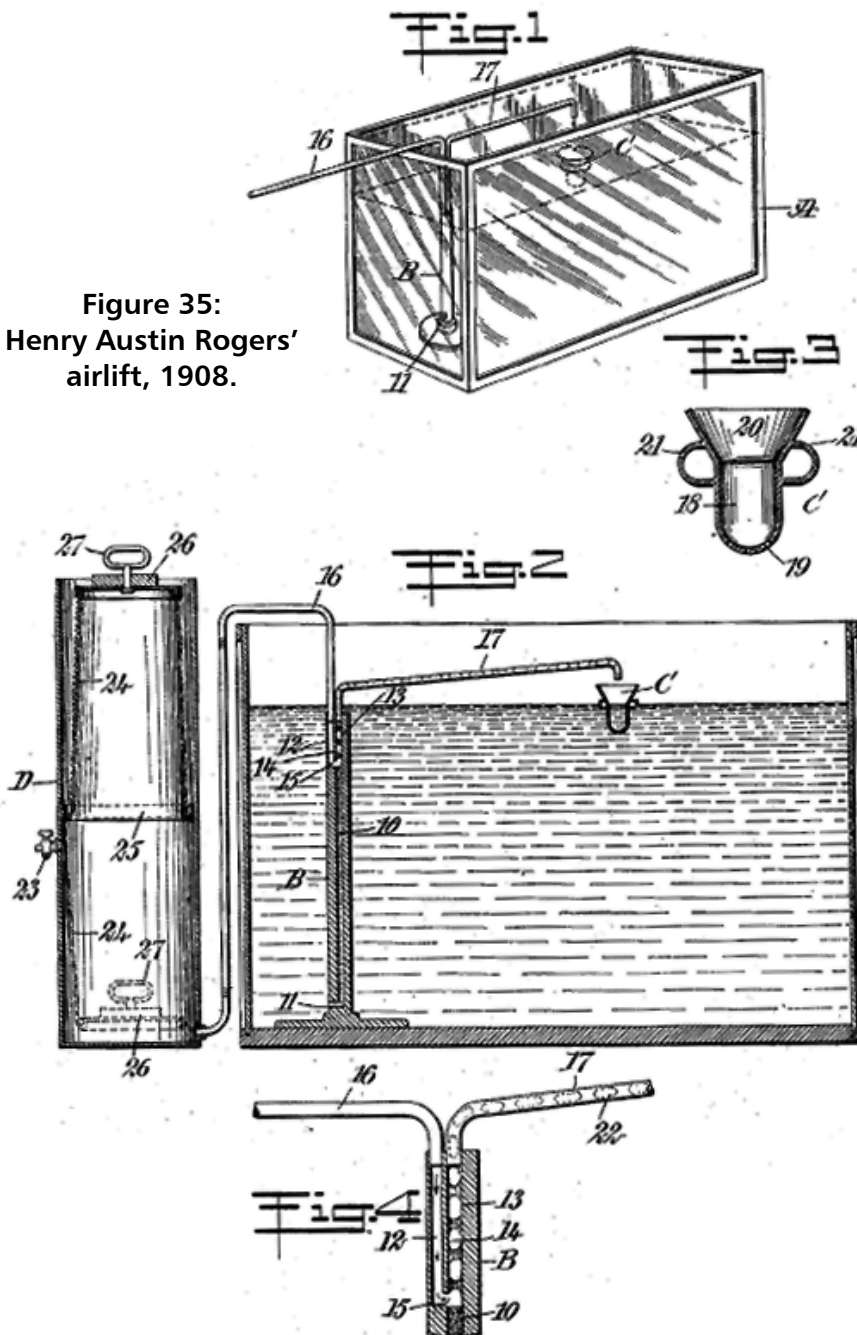

flow controlled in any suitable manner, it escaped in bubbles from the chamber 12 into the chamber 13, and as each bubble rose in chamber 13, it was followed by a volume of water from the chamber 10, causing alternate bubbles of air and drops of water to pass from the chamber 13 to the pipe 17 that the water and air were delivered to the strainer C.

Fig. 2 illustrates a means for supplying air to the pipe 16. This consisted of a cylinder D that was provided between its top and its bottom with a faucet 23 to admit air to the interior of the cylinder. Above the faucet the lower end portion of a jacket 24 was secured, as is illustrated at 25 in Fig. 2. This jacket was made of an air-proof material, and at its upper end,

which normally extended to the upper portion of the cylinder D, was provided with a weight 26 and an attached handle 27. Jacket 24 is elevated by the handle 27 and air was admitted into the cylinder through the faucet 23. When sufficient air was contained in the cylinder to sustain the jacket, the faucet 23 was closed. Then the air was gradually and uniformly supplied to the standpipe B until the weight 26 arrived at the bottom portion of the cylinder D when the cylinder would necessarily have to be again refilled.

[Figure 36, *Apparatus for Supplying Food to Fish or Land Animals, Number 742415*] During this period, Henry S. Hale of Philadelphia patented two automatic fish feeders. The first was in 1903 and utilized a rotating drum partially filled with food.

A discharge container was built into the drum, and Hale showing three different versions where this could be located. When the drum rotated, it filled the discharge container with food that was then pushed out into the aquarium via a measuring valve. Figure 1 is a longitudinal vertical sectional view, Figs. 2 and 3 are similar views illustrating modifications, Fig. 4 is an enlarged detail view of the gravity-actuated valve shown in Fig. 3 and Fig. 5 is an end view of part of the apparatus shown in Fig. 2, showing the valve-operating devices.

A was a shaft in suitable bearings a a and driven in any suitable manner, as by a water-wheel, Fig. 1. In Fig. 1, C is a closed feed chamber or vessel carried by the shaft A and adapted to contain a quantity of feed that could be introduced through a supply-aperture c. D is an outlet from the chamber C for the discharge of feed, which is controlled by a suitable valve E. This valve may be operated automatically or by any positive valve-actuating

Figure 36:
Henry S. Hale's
automatic
feeder, 1903.

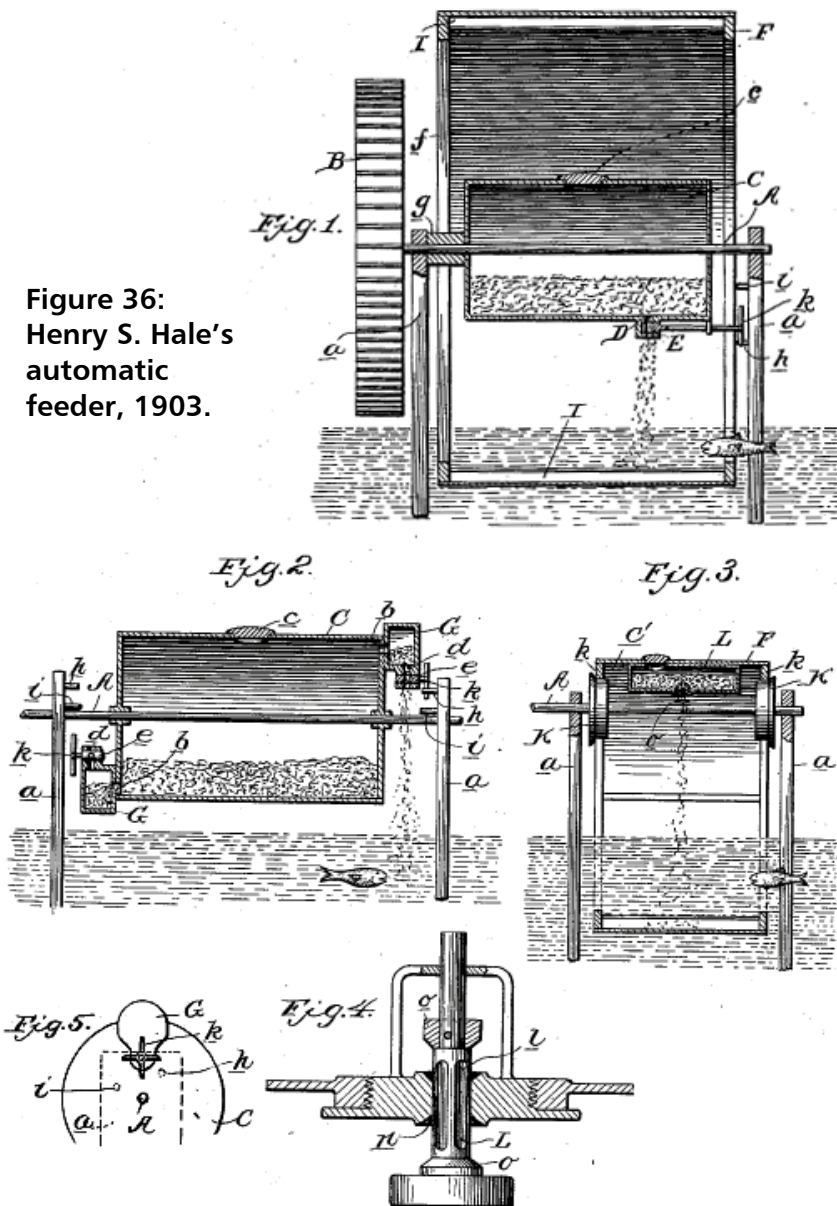

device. In Figs. 1 and 2 the discharge-valve is a rotary valve **S** carried by a stem provided on its end with a star-wheel **k** adapted to strike appropriately disposed pins or projections **h i**, the pin **h** acting to open the valve and the pin **i** to close it.

In fish-feeding it is desirable that the feed should not be allowed to fall and remain upon the bottom so an open receptacle or vessel, more or less submerged in the water, was used into which the feed could fall and by the movement of which such particles of feed as accumulated at the bottom of the receptacle could be raised and dropped again into the water. This receptacle or vessel consisted of a drum **F** carried by the shaft **A** and inclosing the feed-chamber **C**. The drum **F** was open at one or both ends and in the construction shown in Fig. 1 was provided at one end with arms **f** carrying the hub **g** on the shaft **A**. The drum **F** was partly submerged in the water and as the shaft **A** rotated and the valve **E** was opened to discharge a given quantity of feed, the discharged feed fell into the water and was not taken up by the fish. It

accumulated upon the bottom of the drum and was carried up as the drum rotated and was dropped again into the water. For this purpose the interior of the drum was roughened or provided with one or more ribs or flanges **I**.

In Fig. 2 the feed receptacle or chamber **C** was similar to that shown in Fig. 1, except that instead of the discharge-opening **D** leading directly from the chamber Hale employed one or more measuring compartments **G** communicating with the chamber **C** through supply openings **b**, through which a limited quantity of feed could pass from the supply chamber **C** into the measuring compartment. Hale showed two measuring compartments but one or more could be employed. In this construction the outer vessel or drum for catching and raising and dropping the feed was not shown but such device could of course be used.

[Figure 37, *Apparatus for Supplying Food to Fish or Land Animals*, Number 848101] In 1907, Hale obtained a new patent that showed several designs

that actually extended into the water. Fig. 1 in the diagram shows a continuous scoop bucket design; Fig. 2 and Fig. 4 show rotating scoop-arm devices, and Fig. 3 shows a variation on the continuous scoop bucket design. All of these variations save Fig. 3 had provisions to catch the food below the water's surface, thus making it easier for the fish to feed and minimized spreading the food all over the tank. In neither patent does Hale specify the power source, although both clockwork and electric motors were available at the time.

A is a vessel adapted to contain a quantity of feed. **B** is an endless traveling conveyer passing through the body of the feed in the vessel **A**. This conveyer consisted of an endless chain passing over sprocket-wheels **C** **C** to one of which power may be applied in any convenient manner and **b** are buckets carried by the chain.

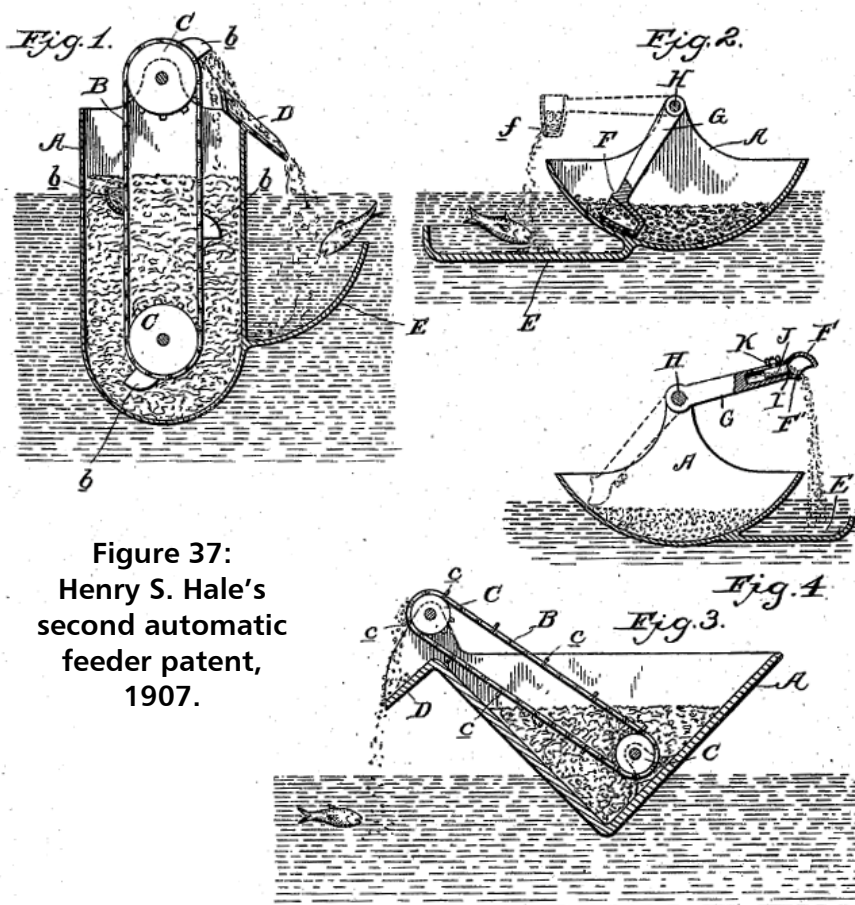

Figure 37:
Henry S. Hale's
second automatic
feeder patent,
1907.

As the conveyer **B** traveled, each bucket *b* would successively take a measured quantity of feed from the vessel **A**, which it discharged upon reaching the top. A trough or guide **D** was arranged at the top of the vessel **A** to receive the feed discharged by the buckets and guide it outside of the vessel **A**. A pan or basin **E** was arranged below the trough or guide **D** to receive the feed as it falls. When the apparatus was used for feeding fish, it was partially submerged in the water. In the construction shown in Fig. 2, instead of the endless chain-and-bucket conveyer shown in Fig. 1 a bucket **F**, carried by an arm **G** on a shaft **H**, was used. The arm **G** was either rotated or rocked so as to cause the bucket to successively enter the feed in the vessel and rise therefrom. By providing an opening *f* in the bucket, the feed was able to escape therefrom when the arm **G** was raised.

In the construction shown in Fig. 3, the conveyer consisted of an endless chain passing over sprocket-wheels but instead of buckets small plates or bars *c* were employed. As in the construction shown in Fig. 1, a guide or trough **D** was used. The conveyer could be operated from time to time by hand power or driven by suitable power devices, in which case the conveyer had to be run at a very low speed, or otherwise an excess of feed would be supplied.

[Figure 38, *Aquarium-Jardinière*, Number 692832] Also issued during this period were three patents for various aquarium designs. The first two appeared in 1902, one by Samuel E. Creasey of Sanford, Maine, the other by Frederick R. Gillinder of Philadelphia. Creasey's "Aquarium Jardinière" combined a globe, a pedestal and a removable flowerpot in its top. Figures 1, 2 and 3 explain the design at a glance.

[Figure 39, *Fish-Jar or Aquarium*, Number 715571] Gillinder's design had the holder for aquatic plants built in.

[Figure 40, *Fountain Aquarium*, Number D37181] The aquarium patented by Frank Hundorf of Covington, Kentucky in 1904, on the other hand, was a traditional fountain design.

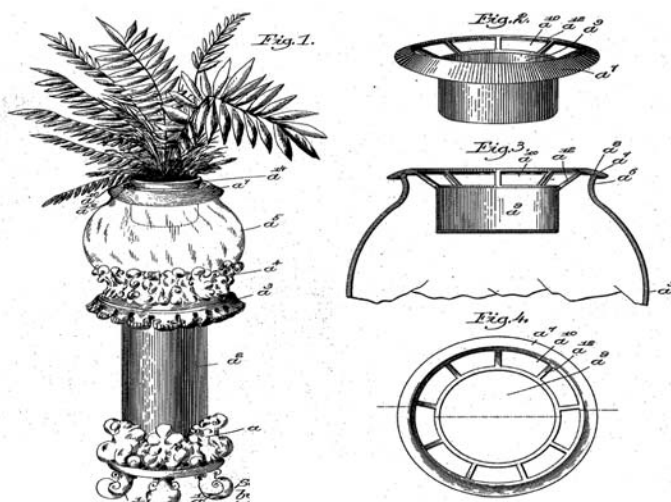

Figure 38: Samuel E. Creasey's "Aquarium Jardinière," 1902.

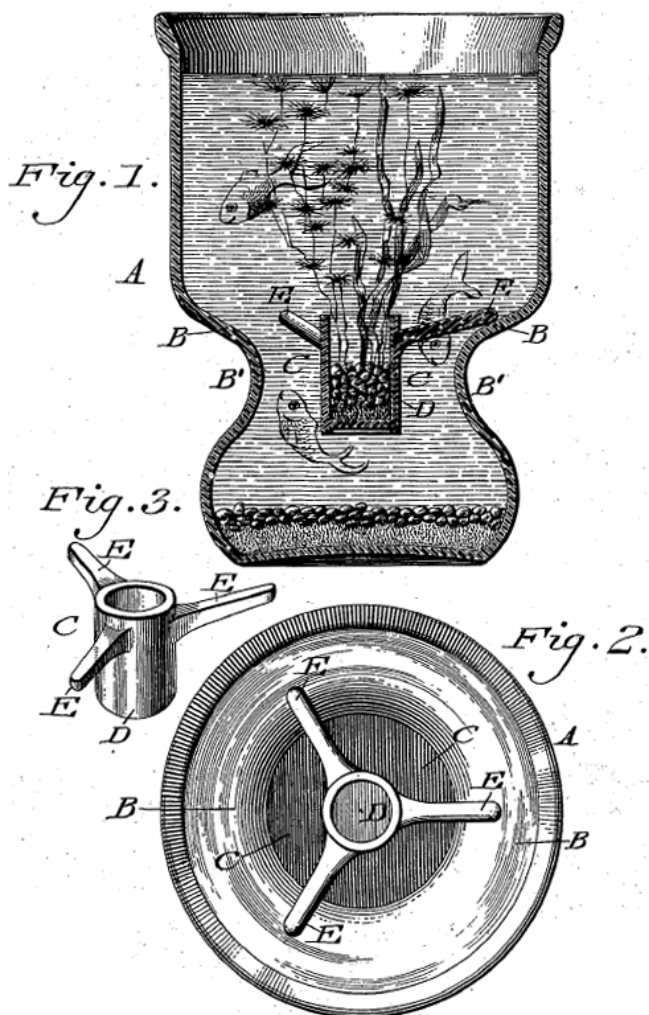

Figure 39: Frederick R. Gillinder's aquarium with removable flowerpot, 1902.

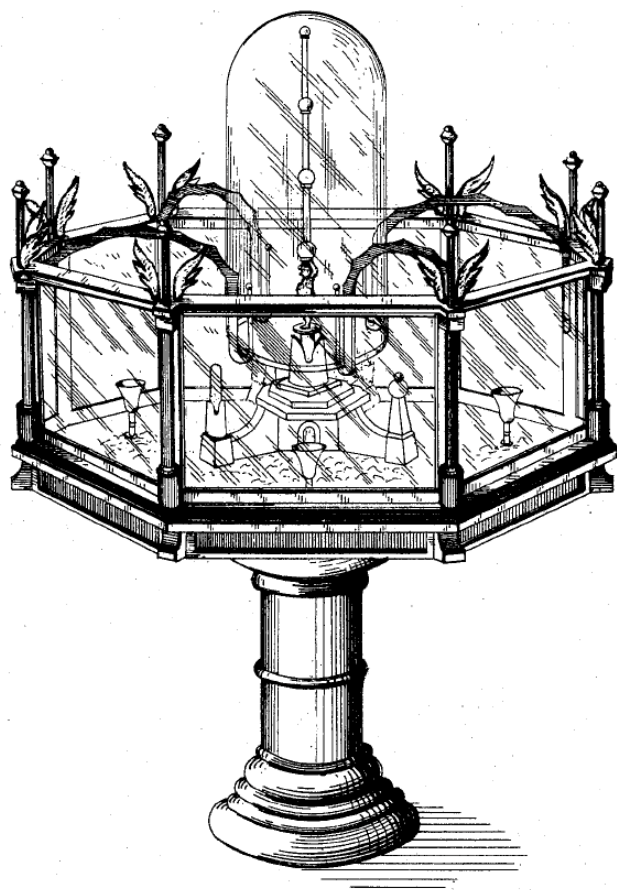

Figure 40: Frank Hundorf's fountain design, 1904.

[Figure 41, *Apparatus for Transporting Live Aquatic Animals*, Number 710325] Two fish transportation patents were awarded during this period. The first was in 1902 to Max Kern and Alfred Wiget of Zurich, Switzerland. This was a shipping can that had a container of air or oxygen fastened to its side, the gas being introduced into the bottom of the can. Oddly enough, nowhere in the patent is there an explanation of how the excess gas escaped from the can! Figure 1 is a vertical section of the apparatus, Fig. 2 is an elevation and Fig. 3 a horizontal section corresponding to the line *CD* of Fig. 2.

Attached to the transport vessel or tank *a* containing the water and the animals - which to facilitate removal could be mounted upon rollers - were two straps *b* and *c* for the purpose of securing a pressure bottle *d* that could contain compressed air or oxygen. An exhaust valve provided at the upper end of the pressure bottle was opened or closed by means of a hand-

wheel *e*. A pressure reducing valve *n* was mounted on a short pipe *f* coupled to the valve seat in the pressure bottle. The pressure in the bottle and the reduced pressure could both be measured by the pressure gauges *l* and *m*. The pipe on which was mounted the reducing valve was connected with a pipe *f'* that was attached to the tank *a* and extended to its bottom where it was bent in the form of a curve. The curved portion was provided with a number of fine openings *g* that allowed the oxygen or the air supplied through the reducing valve at reduced pressure to escape slowly or in successive small quantities.

In order that the air or oxygen as it rose agitated the water and was distributed or diffused in the tank *a*, there was arranged within the tank, above the ports or openings *g* of the pipe *f'* on its floor, a sieve *h* to the underside of which adhered bubbles that would unite to form larger bubbles, which then rose in the water setting it in motion and becoming distributed, diffused, or subdivided and sending to the tank the necessary oxygen needed for prolonged retention of the fish in the tank.

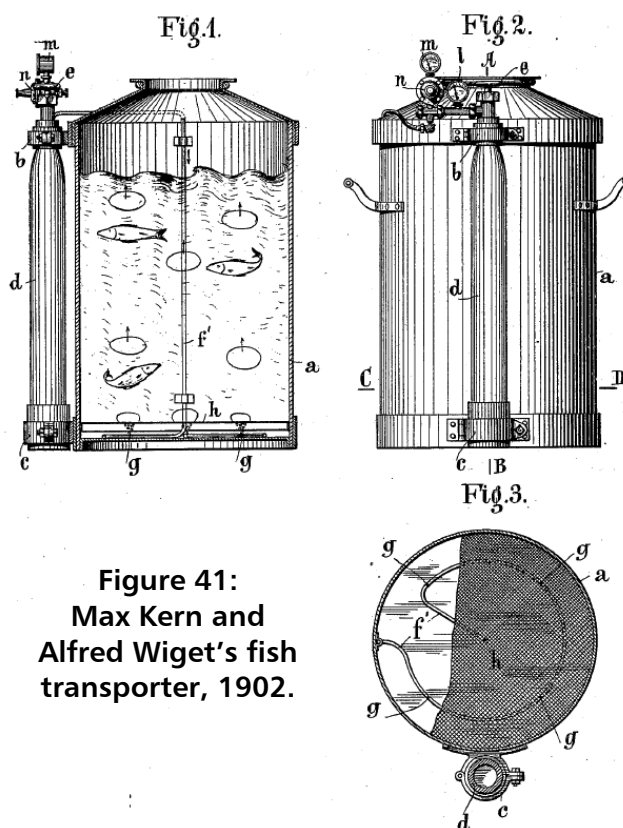

Figure 41:
Max Kern and
Alfred Wiget's fish
transporter, 1902.

[Figure 42, *Live Fish Holder*, Number 846864] The second patent was awarded to Charles J. Remsburg, of Lewistown, Maryland in 1907. Remsburg's design had two aims: (1) to minimize the splashing of water during transport by the use of a perforated cover on the can, filled to its very top so that the water could not splash, and (2) to minimize the wasted space when the cans were placed alongside each other by use of a rectangular design. In the diagram, the perforated ring around the top of the can allowed air to find its way to the perforated cover when the cans were stacked on top of each other. Figure 1 represents a vertical section through the can and Figure 2 represents a plan view, partly broken out to more clearly show some of the details.

A somewhat dome-shaped top 9, having perforations 10 and a central opening 11, had its flanges 12 secured within the sides 5 at such a distance below the upper edges of the latter that no portion of the top or of the cover 13 projected above the upper edges of the sides 5, thereby enabling one holder to be set squarely on another. The top, having sloping portions and the vertical flanges 12, could be secured within the body by any suitable means such as rivets. The top was formed with an inwardly-projecting shoulder 14 to support the cover 13. The cover 13 was perforated or formed with small openings to increase the access of air to the space between the top and the surface of the water contained in the body. The openings in the cover also served to permit water poured onto the cover to gain access to the interior of the holder. After the live fish and a certain quantity of water were in the holder it was frequently desirable to add more water, either to supply the fish with a proper quantity or to occasionally replace the amount of water that may have evaporated. By pouring such water onto the cover 13 after the latter had been put in place, it would percolate through the openings in the cover. By this means the possibility was avoided of supplying the water too violently and so a mad dash among the fish was avoided. The cover could be secured on its seat by any suitable means as, for instance, by a flexible strap 15 secured at its outer end to the upper surface of the top 9 and at its other end to the 5 upper edge of the flange of the cover 13. Another strap or hasp 16 could be connect-

ed to the opposite side of the cover 13, the outer end of such a hasp fitting over a staple secured to the top 9 and locked in place by a padlock 17. Any other means, however, could be employed for securing the cover 13 in place.

When during transportation of a holder any lateral shaking or agitation occurred so as to throw water up against the perforated top 9, only a small quantity of water could find its way through the perforations 10 because the perforations were so small as to break up the force of water dashing against the underside of the top. Such water as may be thrown through the perforations 10 would readily find its way back through the perforations as soon as the water below the top 9 returned to a lower level. A suitable pump for forcing air into the water contained in the holder could be employed, such as indicated at 20 in Fig. 2.

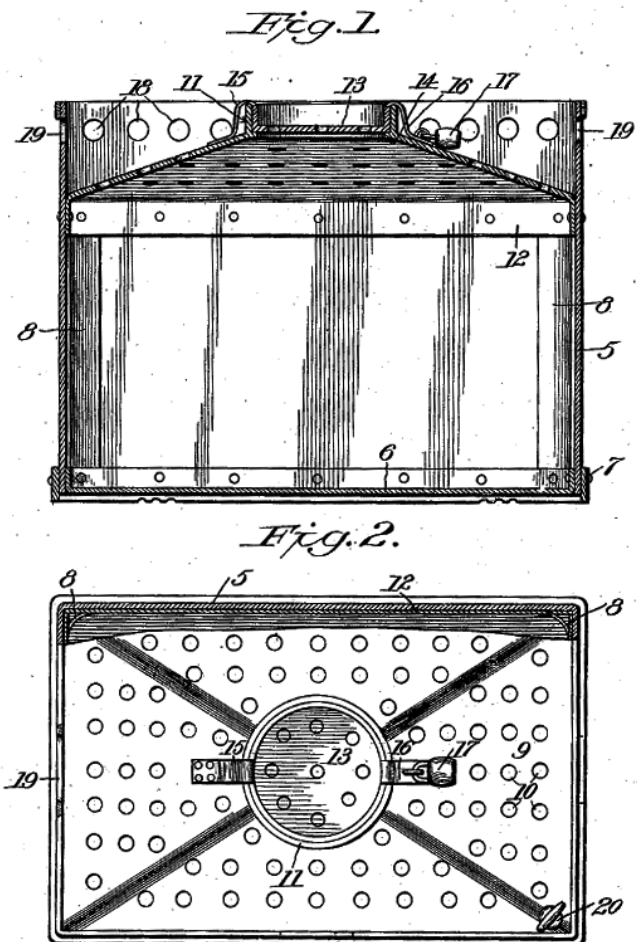

Figure 42: Charles J. Remsburg's shipping can, 1907.



WORLD WAR I: THE DECADE OF 1909-1918

[Figure 43, *Apparatus for Aerating Water*, Number 950999] Three designs for aerating aquariums were assigned during this decade. The first two appeared on the scene in 1910, one by Georg Erlwein and Ernst Marquardt of Berlin, Germany and the other

by John F. Wohlfahrt of St. Louis, Missouri. In the Erlwein/Marquardt design, a water-jet injector forced an air/water mixture into a porous vessel **W**. The water escaped out pipe **C** and out through the nozzle, **S**, carrying with it small bubbles of air. The air separated from the water in **W** escaped through the pores in the form of very fine bubbles.

If the porous material became clogged, the water level in **W** would rise and more water would exit to the nozzle **S**. This arrangement produced a very effective distribution of air through the water, thus increasing the amount of oxygen absorbed by the water in the aquarium. It is the first mention in a patent of the use of a porous medium in an air release, making it the forerunner of our familiar air stone.

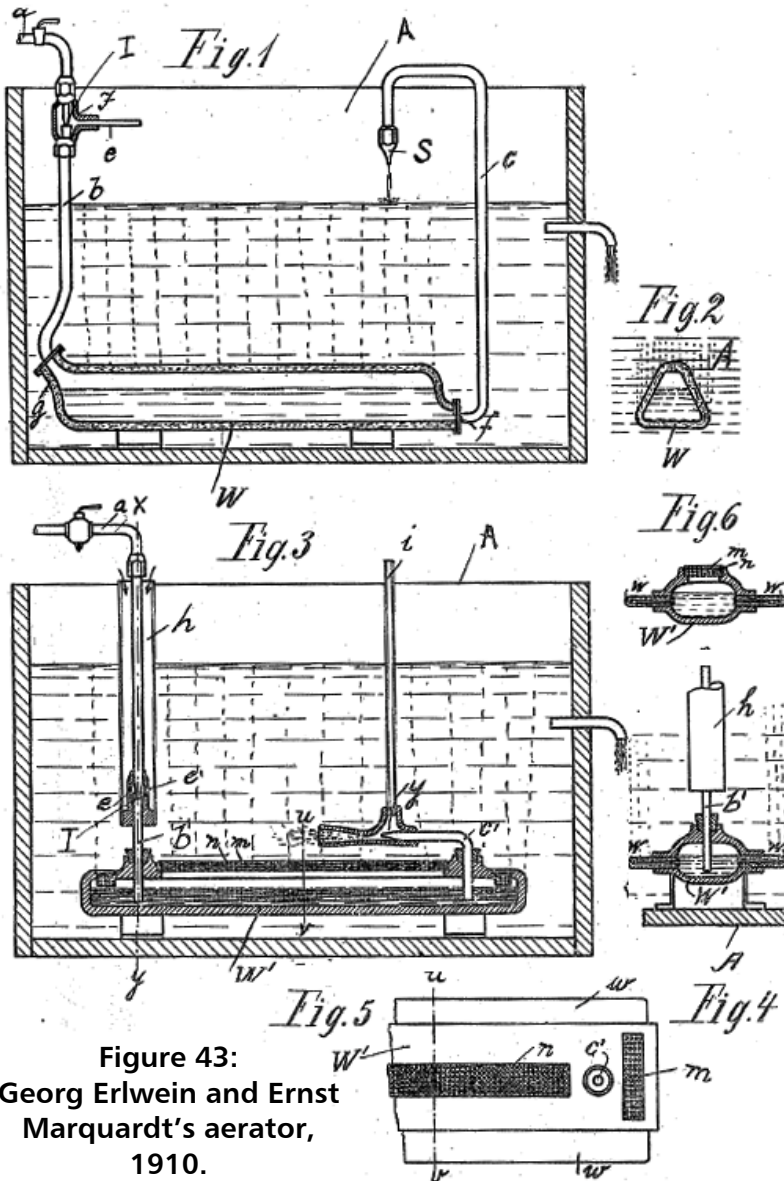

Figure 43:
Georg Erlwein and Ernst
Marquardt's aerator,
1910.

Figure 1 is a vertical longitudinal section, Fig. 2 is a vertical transverse section, Fig. 3 is a vertical longitudinal section through a modified form and Fig. 4 is a vertical transverse section of this modified form in the plane **x y**, parts being broken away, showing substantially the arrangement of the air vessel in this plane. Fig. 5 is a top plan view of the right hand side of same air vessel and Fig. 6 is a transverse section through the air vessel in the plane **u v**.

I is a water-jet injector which is fed through pipe **a** and sucks in air through the pipe **e**. The mixture of air and water was forced into the porous cylindrical or triangular vessel **W** through pipe **b** and

the neck *g* of the vessel. In this vessel the water separated from the air carried in by it. In this vessel the pressure above atmospheric, which adjusts itself to a certain extent, forced the water through the socket *f* and pipe *e* and the water flowed on through the nozzle *S* at a pressure of a few tenths of an atmosphere above atmospheric into the water in the tank or receptacle *A* carrying along with it small bubbles of air and distributing them in the water. The air separated from the water in the vessel *W* escaped through the pores of the wall above the water level in this vessel in the form of very small bubbles into the water in the tank *A*. The water in this tank was very effectively aerated thereby and also by the air carried along by the jet from the nozzle since gas passes from the air into the liquid and, reversely, from the liquid into the rising bubbles both at the surface of the porous wall of the vessel and also at that of all the small bubbles of air. Corresponding to the partial pressures and solubilities, oxygen diffused materially in the water whereas carbonic acid went into the escaping bubbles rich in nitrogen as long as there was an excess of carbonic acid in the water.

The vessel *W* that was simultaneously water separator, air vessel, air distributor and regulating valve for the emitting air could be shaped and arranged in various ways according to the manner in which the apparatus was to be employed in each instance. For a

small apparatus it was preferable to use pipes of porous cement, porous porcelain, calcareous sandstone or also porous wood, preferably of cylindrical or triangular cross-section, whereas for larger plants vessels comprising parts composed of metal and porous or perforated material are better, as in the form shown in Figs. 3 to 6.

In the constructional form represented in Figs. 3 to 6 the injector *I*¹ was arranged below the surface of the water in the tank *A* in order to shorten the pipe *b*¹ and in this manner to diminish as much as possible the friction of the mixture of water and air, whereby a more favorable effect was obtained with regard to the quantity of air supplied. The air sucked by the injector passed through the pipe *h* and the orifices *c*¹.

[Figure 44, *Aquarium*, Number 976242] Wohlfahrt described his 1910 aeration system as follows: "This invention relates to a new and useful improvement in aquariums, the objects of my invention being to provide a construction in which the water tank could be cleansed without removing the fish from the aquarium; in which the water could be automatically and intermittently drawn off from the bottom of the tank, the volume of the water in the tank being reduced to any desired or predetermined depth, the tank also adapted to be in communication with a continuous stream of fresh water, whereby a circula-

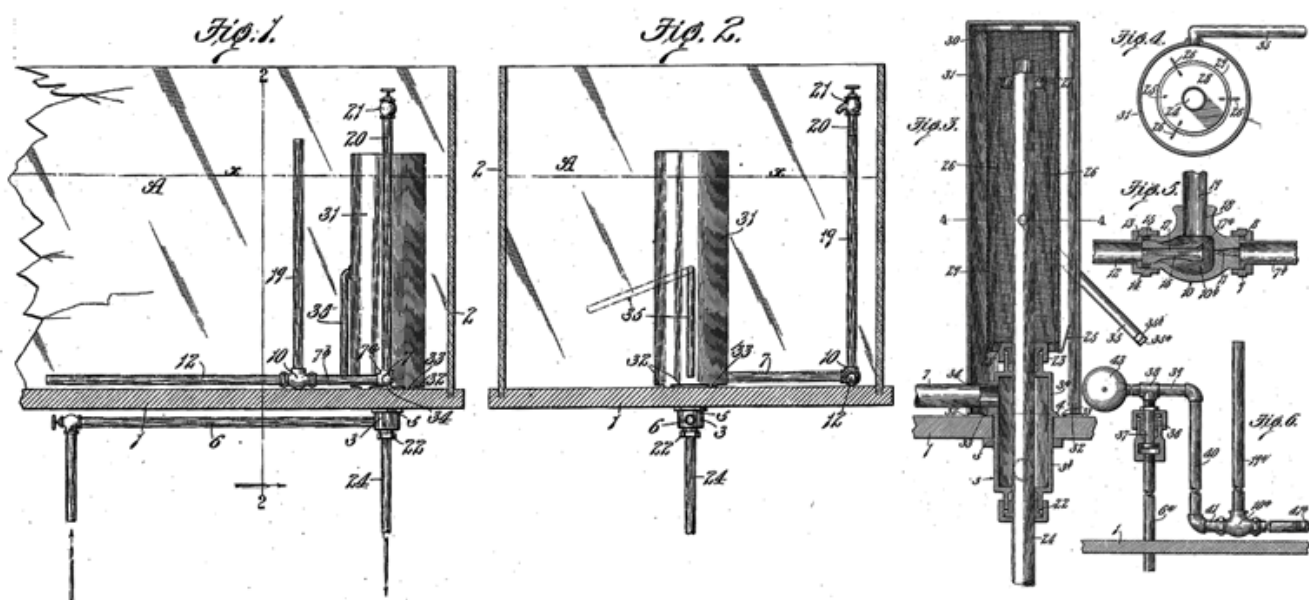

Figure 44: John F. Wohlfahrt's aeration system, 1910.

tion of water in and through the tank was maintained and the water kept in a health state or condition beneficial to the fish in the aquarium; and in which the water in the tank was aerated; and to improve generally upon constructions of the kind described." Obviously such designs were not really practical for the average aquarist, being more suitable for public aquaria.

Figure 1 is a sectional view of an aquarium equipped with the invention, showing in side elevation the improved means for supplying the tank with water mixed with air and of cleaning the tank by intermittently drawing water off the bottom of the tank; Fig. 2 is a vertical sectional view on line 2 - 2 in Fig. 1, Fig. 3 is an enlarged detail sectional view, Fig. 4 is a transverse sectional view on line 4 - 4 in Fig. 3, Fig. 5 is an enlarged detail sectional view of the injector, showing the ends of the air and water supply pipes connected thereto, and Fig. 6 is a detail view, partly in section, illustrating a modified form of arrangement of the water and air supply pipes.

Water under ordinary hydrant pressure entered injector 10 from pipe 7^b and, in entering injector through inlet opening 11, was reduced to the form of a fine stream, a vacuum being produced in the interior 10^b of injector 10, and the water on entering nozzle 16 drew or sucked therewith the air from pipe 19. As the water was again reduced while passing through nozzle 16 to a narrow stream, the air and water were mixed or intermingled so that when the water passed into discharge pipe 12 and into tank A, the air would be carried along therewith and the water in the tank A was thus aerated.

A pipe 20 extending above the water line X in tank A and having a faucet 21 at its upper end, could be connected to pipe 7 at the joint 7^a, whereby water could also be delivered into tank A if desired. Extending through member 3 and secured therein by stuffing boxes 22 and 23, as shown in Fig. 3, was an upstanding discharge pipe 24. As the water in the tank A discharged through this pipe the water line in the tank A or the height to which it was desired that the water should go in filling the tank, would depend upon the distance the upper end of pipe 24 was from

the base 1 of tank A, the height to which the water should go in filling the tank A being thus adapted to be regulated by the length of pipe 24 within tank A, the lower end of pipe 24 extending some distance below base 1 of tank A and into a suitable sewer or other place of discharge, not shown.

The water was adapted to be continuously supplied to tank A from supply pipe 6 through member 3 and pipes 7^a, 7^b and injector 10, the water while passing through injector 10 sucking the air along therewith and into tank A. The pipe 35 was adjusted or swung according to the depth to which it was desired that the tank should be emptied. Should it be desired to empty the tank within a very short distance from the bottom thereof, the pipe 35 was arranged parallel with member 31 as shown in full lines in Fig. 2, but should it be desired to empty the tank at a greater distance from the bottom or base 1, the pipe 35 was swung upwardly accordingly as shown by dotted lines in Fig. 2. As the water rose in tank A, the water likewise rose within member 31, the water in rising also covering and closing the outer end 35^a of pipe 35, thereby cutting off the entrance of air into member 31.

As soon as the water reached the top of pipe 24 within member 31, the water would begin to discharge through pipe 24, on the principle of the siphon, and would continue to discharge through pipe 24 until the water had been drawn off from tank A or emptied down to below the end 35^a of pipe 35 at which point air would enter member 31 through pipe 35 and the discharge of water would be discontinued. As the water entered member 31 through the inlet openings 32 at the bottom thereof, the water was drawn off from the bottom of the tank and thus the water carried therewith all foreign matter that be in the tank, such foreign matter being caught by the gauze member 29 as the water passed through into pipe 24, the tank being thus cleaned without necessitating the removal of the fish in the aquarium. The gauze member 29 could be readily removed whenever it was desired to clean the tank. As the water was continuously entering tank, it would soon again fill the tank to the level of the top of pipe 24 when the tank will be again emptied down to the end 35^a of pipe 35 and

so on, the water in the tank being in this way automatically and intermittently discharged, whereby a circulation of water in and through the tank was maintained and the water was kept in a healthy state.

In Fig. 6 Wohlfahrt showed a modified form of arrangement of the water and air supply pipes. In small aquariums the arrangement of the air and water supply pipes which was just described was preferred, but in large tanks it was preferable that the air and fresh water should be distributed around the tank.

[Figure 45, *Aquarium Attachment, Number 1055082*] The last aeration patent in this set was awarded in 1913 to Henry A. Rogers of Pagosa Junction, Colorado, a refinement of his 1908 patent. In this improvement he enlarged the filter (which held "...sand or another filtering medium...") and attached it to the inside of the tank. Figure 1 is a sectional elevation showing an aquarium tank supplied with the attachment; Fig. 2 is a perspective view of

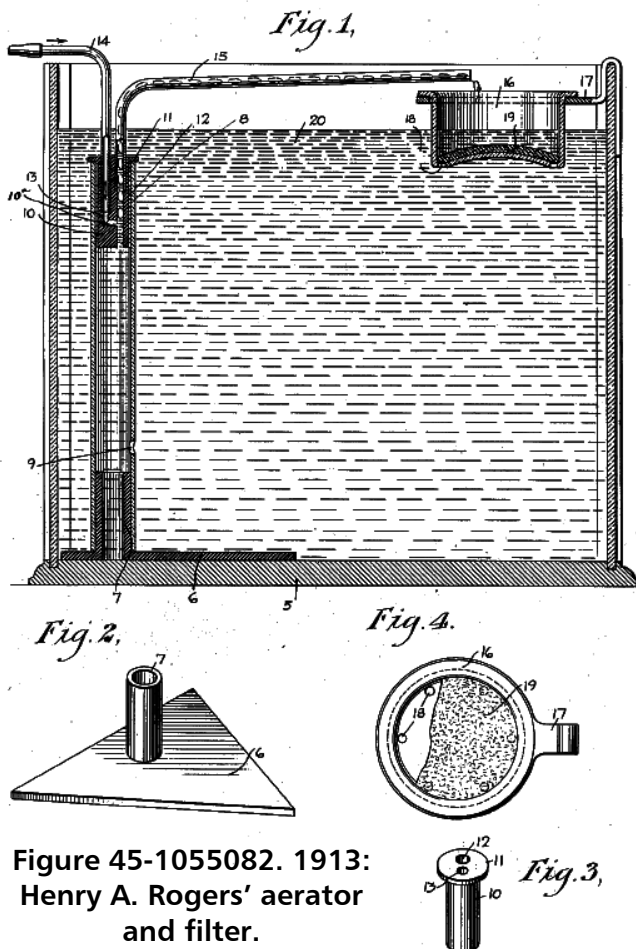

Figure 45-1055082. 1913:
Henry A. Rogers' aerator
and filter.

the base member with its collar for supporting the vertical tube, Fig. 3 is a perspective view showing the plug which is inserted in the upper terminal of the vertical tube and Fig. 4 is a plan view of the filter containing the filter medium, the filter medium being removed showing a portion of the filter to show the construction of the latter.

In operation, air was forced by a pump or any other suitable means into the conduit 13, through the bent tube 14, the air passing through the passage 10^a to the conduit 12. Mixing with the water in the conduit 12, the air escaped in bubbles through conduit 12 and the bent tube 15, carrying with it volumes of water between the bubbles of air, the bubbles of air and volumes of water being discharged from the tube 15 above the filter 16, the water being returned to the motor in the aquarium through the filter, the filtering medium 19 and the orifices 18. In this way a slow and even circulation of water in the aquarium tank was obtained, while the water was enriched to support life in the aquarium by the air which was introduced through the bent tube 4.

The members of the device were so constructed that they could be readily removed without disturbing the contents of the tank. When it was desired to remove the attachment, the bent tubes 14 and 15 could readily be removed from the plug 10 and plug be removed, either alone or with the vertical tube 8. The filter could also be removed by means of the brackets 17 that were mounted at the side of the tank 5. The attachment could be constructed at very little expense. Should one of the members be broken or damaged in any way it could be replaced without the necessity of purchasing a complete attachment.

[Figure 46, *Aquarium, Number D49292*] The remaining constructs in this decade were mainly design patents for globes, bowls and other aquaria. The first patents for a flat-sided fish bowl went to George R. West of Pittsburg with two 1916 designs and this was his first.

[Figures 47, *Combined Aquarium and Vase, Number D49480*] The second was similar to his first except that it had a plug in fish bowl opening

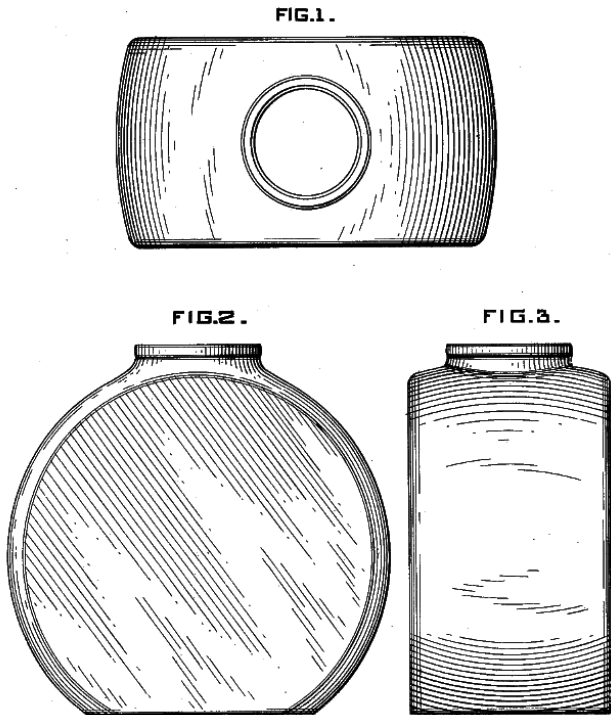

Figure 46: George R. West's flat-sided fish bowl, 1916.

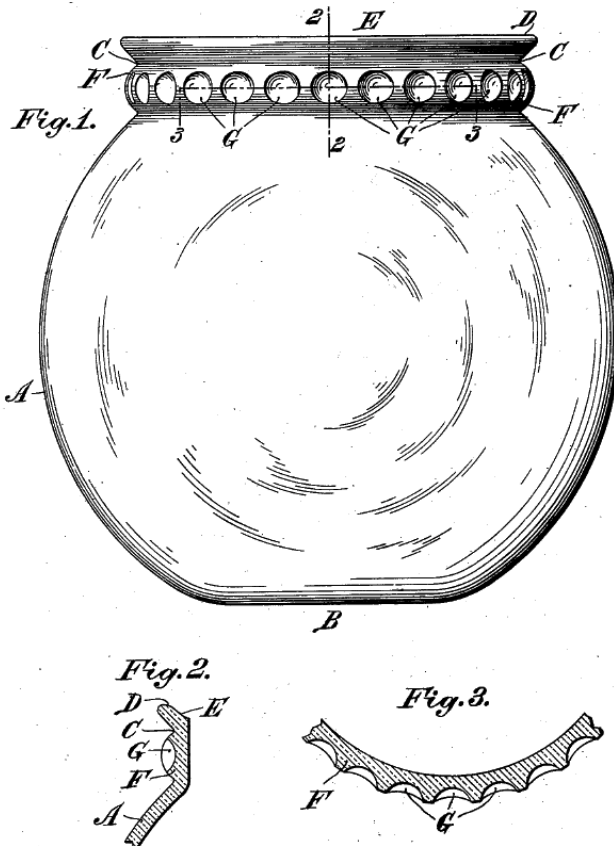

Figure 48: Kraft Booth's fish globe design, 1909.

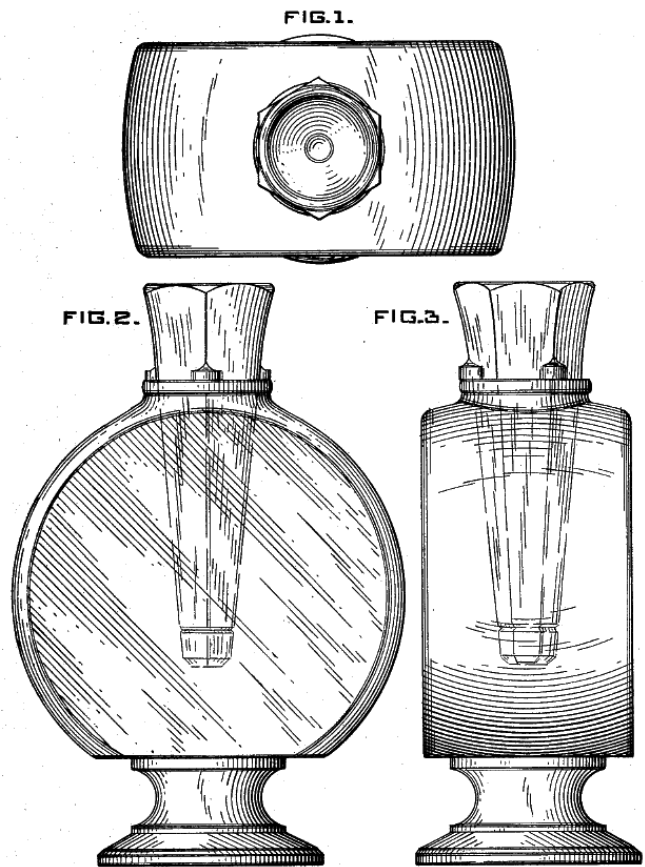

Figure 47: George R. West's plug in a flat-sided fish bowl, 1916.

that accommodated a vase to hold plants. This was a poor idea since it reduced oxygen absorption at the water surface.

[Figure 48, *Fish Bowl*, Number 925861] More conventional globe designs were represented by those of Kraft Booth of Philadelphia in 1909,

[Figure 49, *Fish Bowl and Support*, Number D51433] Herrman Simons of Cincinnati in 1917 and

[Figure 50, *Bowl for Goldfish*, Number D51663] Jesse L. Turner of Morgantown, West Virginia in 1918.

[Figure 51, *Combined Fountain and Aquarium*, Number 919157] An elaborate fountain aquarium design was patented in 1909 by Rudolf Glaser of New York City. Glaser's fountain was surrounded by

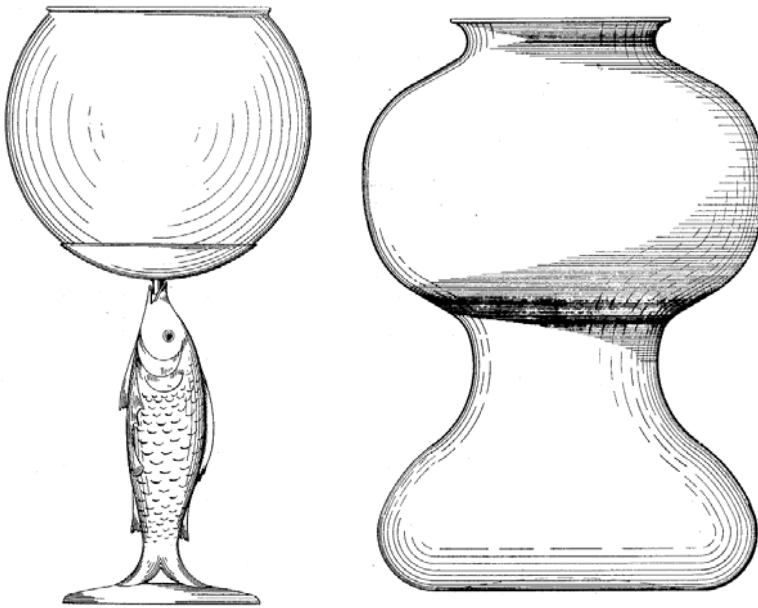

LEFT Figure 49: Herrman Simons's Sleek design, 1917.

RIGHT Figure 50: Jesse L. Turner's fish globe and stand design, 1918.

two stepped circular aquaria complete with plants and illuminated by electric lights both in the center and overhead. Figure 1 is a plan view, and Fig. 2 is a vertical section thereof.

The aquarium consisted of a glass vessel of an annular form, having a circular outer wall 1 and an inner wall 2 of similar form. The aquarium therefore was susceptible of illumination by lights placed within its central opening, while the space between the walls 1 and 2 could be filled with water containing marine animals and plants. The central opening of the aquarium was covered by a dome-shaped cover 3 of glass or other translucent material, preferably colored, and the cover and the wall 2 were securely connected by means of a grooved collar 4 at their juncture.

The fountain comprised a number of arms 5 springing from a riser pipe 6 which projected from the top of the cover 3. The arms 5 constituted nozzles from which the water was delivered in jets that fell upon the cover 3 and into the aquarium. The water by which the fountain was supplied was drawn from the aquarium and was raised to the fountain by a rotary pump 7 beneath the aquarium. The pump was driven by an electric motor 8 and was supplied from the

aquarium through an inlet pipe 9 controlled by a valve 10. By means of this valve the amount of water issuing from the fountain could be conveniently regulated.

The ornamental appearance of the structure above described was greatly enhanced by the use of electric lights 11 were arranged just above the fountain, and they served to illuminate the falling jets of water, the cover 3 and the aquarium. To further enhance the effect by illuminating the structure from the interior, electric lamps 13 were mounted upon the riser pipe 6. The light from these lamps

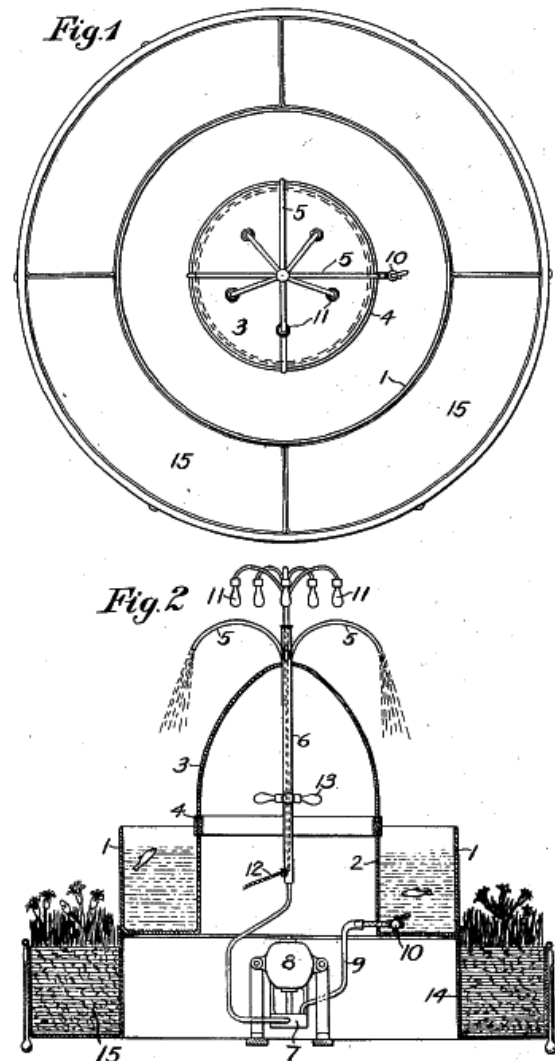

Figure 51: Rudolf Glaser's fountain Aquarium, 1909.



FIG. 1.

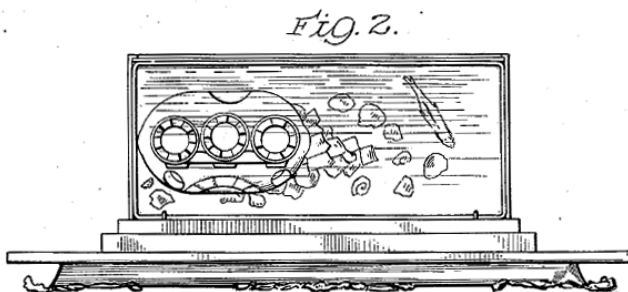

FIG. 2.

Figure 52: Francis A. Ronneburg's framed Aquarium, 1912.

shone through the inner wall of the aquarium and illuminated the contents of the aquarium in a novel manner, and the light also shone through the cover 3 and the water trickling over it. The electric lamps 11 and 13 were connected with a suitable source of electricity by wires 12 passing through the riser pipe 6. The motor 8 could also be energized from the same source. The aquarium was supported on a hollow stand 14 which served as a casing for the pump and the motor. The stand was also formed to contain curved plant boxes or ferneries 15 surrounding the aquarium.

[Figure 52, *Aquarium*, Number D43062] An aquarium with a very ornamental frame was designed in 1912 by Francis A. Ronneburg of Chicago,

[Figure 53, *Design for an Aquarium*, Number D48108] and a very modern looking one in 1915 by John Halterbeck of New York City.

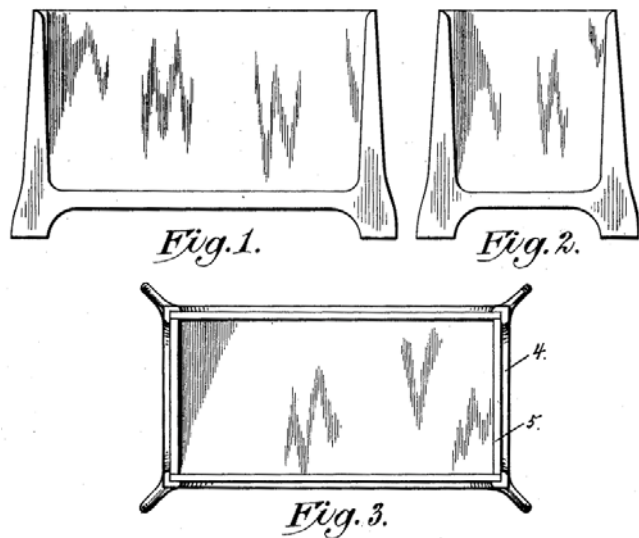

FIG. 1.

FIG. 2.

FIG. 3.

Figure 53: 1915: John Halterbeck's modern design, 1915.

[Figure 54, *Design for an Aquarium*, Number D41977] A simple, sloping wall aquarium design by Samuel Jacob of Philadelphia appeared in 1911.

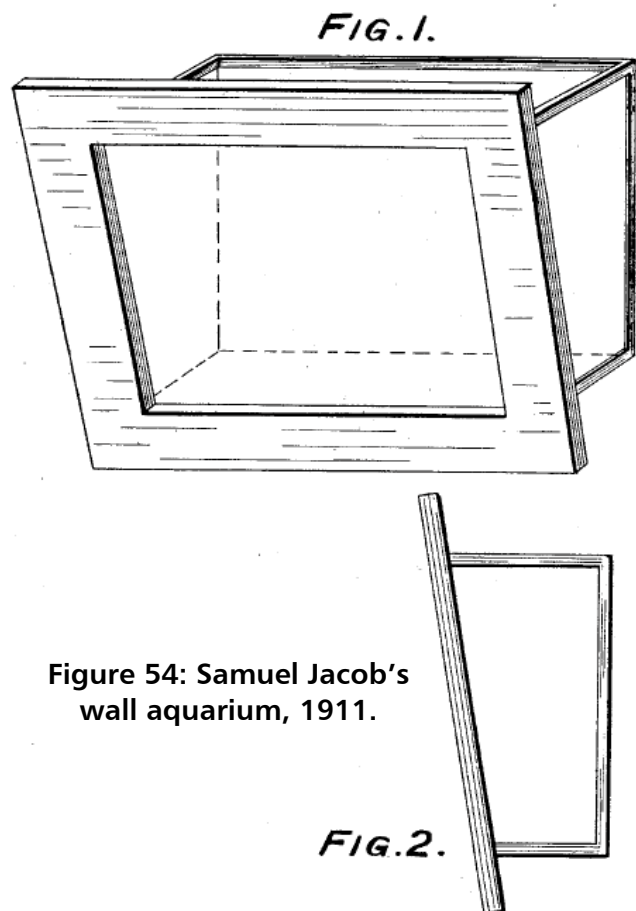

FIG. 1.

Figure 54: Samuel Jacob's wall aquarium, 1911.

FIG. 2.

[Figure 55, *Aquarium*, Number 1127976] Several novel aquariums also surfaced during this period, notably the trough-like design by Edgar C. Ely of Carbondale, Pennsylvania in 1915 that limited the number of joints that needed water-proofing to just the two ends of the tank. Figure 1 is a side view, half in section and half in elevation; Fig. 2 is an end view, half in section and half in elevation; Fig. 3 is an enlarged sectional detail in the vertical plane of one of the top bolts and Fig. 4 is a fragmentary horizontal section at one end of the structure.

1 designated the glass aquarium body of a relatively long trough form. The body preferably had an open top and was approximately semi-cylindrical or U-shaped in cross-section, although the cross sectional shape could vary somewhat. The ends were open and the glass body could be defined in one way as an open-ended, open top trough or semi-cylinder of glass. The body was provided with two end plates or standards 2 the principal parts of which conformed approximately to the outline of the ends of the glass

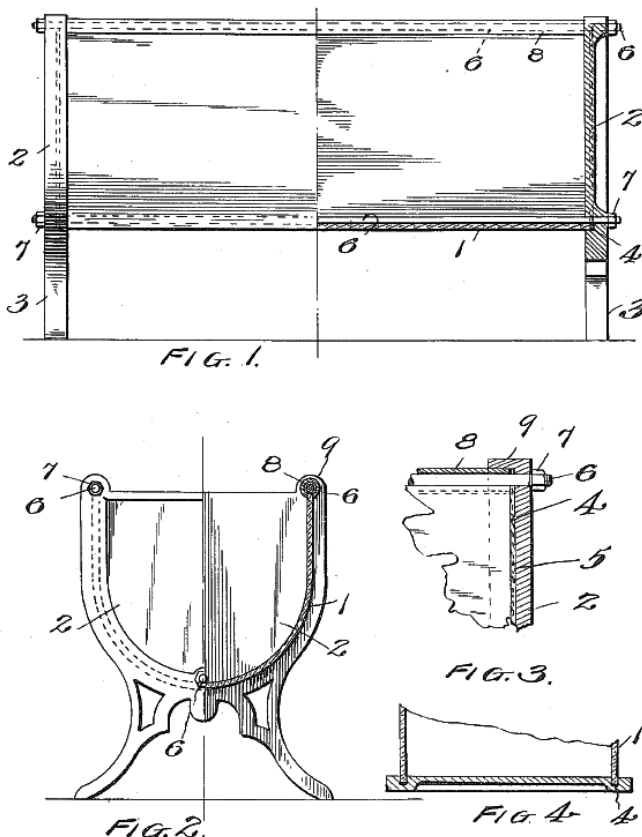

Figure 55: Edgar C. Ely's trough Design, 1915.

body but were slightly larger; these standards were usually provided with legs 3. In each of the end plates was a channel 4 into which the ends of the glass body fit. At the bottom of each channel was a gasket 5. The whole structure was drawn together so that the gaskets were tightly clamped on the ends of the glass body to make the trough watertight using bolts 6, two of which were at the tops of the sides of the glass trough and one was at the bottom within the trough. These bolts were provided with nuts 7 and suitable waterproofing could be placed under the nuts of the lower bolt to prevent water from leaking out at this point.

To improve the sightliness of the whole structure, the upper bolts 6 and the upper edges of the glass body were concealed by metal tubes 8 through which the bolts passed. These tubes were cut away at one side to overlap the upper edges of the glass body. The tubes extended at the ends into enlargements of channels 4 in the end plates, the plates being provided to accommodate these tubes with extensions 9 surrounding the enlargements of the channels. The bottom bolt 6 could be entirely concealed from view through the glass by sand, stones, vegetation or other articles placed within the aquarium when the latter was in use.

The semi-cylindrical shape of the body rendered it sufficiently stiff so that it could well withstand the considerable pressure placed upon it by tightening the bolts to properly compress the gaskets and make the structure perfectly water-tight. An aquarium constructed as above had considerable flexibility. When placed on a slightly uneven base the end pieces could move slightly in relation to each other, permitting the aquarium to rest firmly and without any injurious additional strain to the glass body, this twisting of the structure being permitted by a slight flexure of the bolts, by the flexible packing and in some cases possibly by a slight bending of the glass body itself, which in the described structure could take place without disadvantageous results.

[Figure 56, *Design for an Aquarium*, Number D48946] Another was the odd design by Joseph Nowicki of Detroit in 1916. For a simple globe

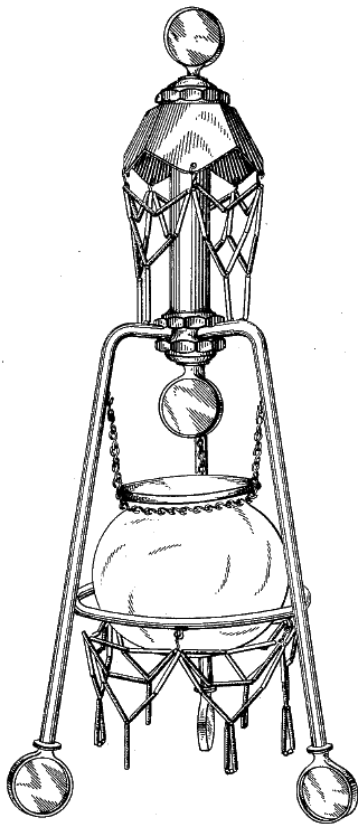

Figure 56: Joseph Nowicki's "gingerbread" aquarium and stand, 1916.

aquarium, this one had more embellishments than a Christmas gingerbread house!

[Figure 57, *Aquarium*, Number 1169449] In 1916 Jacob Williamson of Chicago devised an aquarium in which the gravel and plants could be removed and cleaned without removing the water or the fish. He also provided a way to supply fresh water to the aquarium slowly, so as to maintain the level of the water in the tank without changing the temperature suddenly and endangering the health of the fish. The diagram shows a cylindrical aquarium with a tray in the bottom attached to a rod. The end of the rod has a small circular plate to which was attached a cylindrical woven wire cage. At the top of the wire cage a glass bottle was attached, open at the top and closed at the bottom by a cork attached a wooden peg, the lower portion of the peg having a small groove that permitted water to slowly enter the aquarium. The rate the water was released could be controlled by rotating the peg. The cage was filled with gravel into

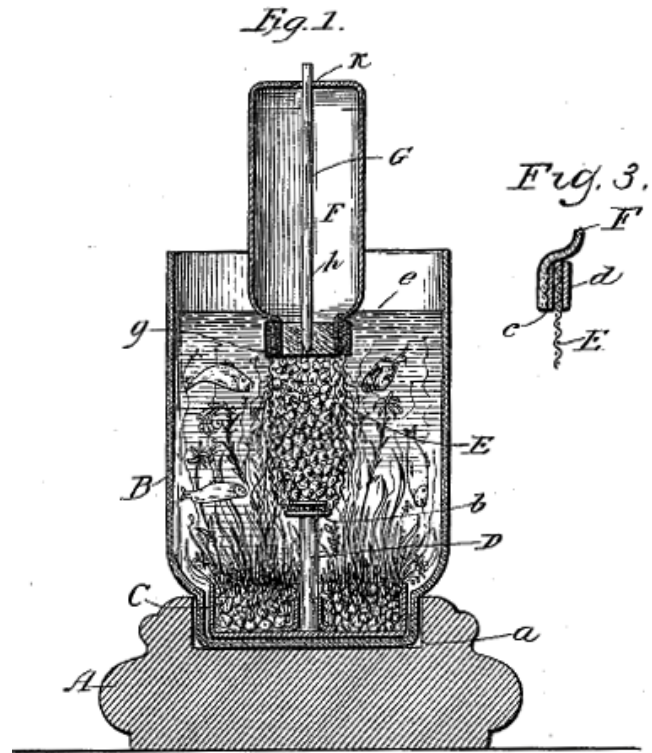

Fig. 2

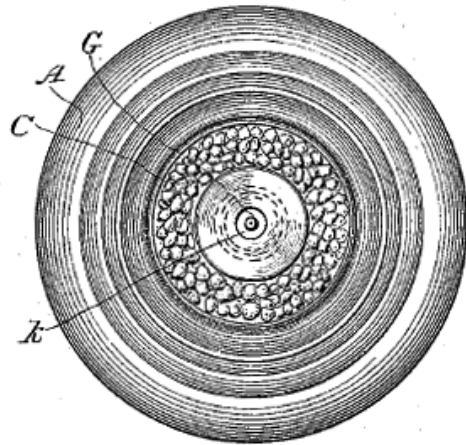

Figure 57: Jacob Williamson's design with removable gravel and plant holders, 1916.

which aquatic plants could be planted and, at intervals, the tray with the bottle could be lifted out of the aquarium without disturbing either the fish or the plants. Figure 1 is a vertical central section; Fig. 2 is a transverse section taken on dotted line 2 - 2 in Fig. 1 and Fig. 3 is a detail view.

The lower reduced bottom of the aquarium had a tray G seated therein that conformed to and fitted

snugly in the bottom. Its edges were flanged or built upward so as to enable it to retain a sufficient quantity of gravel and sand or such other mineral and vegetable matter as it could be desired to place therein. At about its center the tray **C** had a post **D** arising from it, the lower end of which is shown to be secured to the bottom of the tray by means of a socket in which it was secured by soldering, riveting or otherwise. The upper end of this post had a circular plate **b** secured to which the lower annular edges of a cylindrical woven wire cage **E** were supported and secured. The upper end of this cage extended very nearly to the surface of the water in the aquarium, and its upper edge portion was reinforced by inner and outer rings **c** and **d** in any suitable manner; the inner ring **c** was provided with a coarse screw-thread as shown.

F represented a cylindrical fountain of glass or other material which had its lower end *e* reduced and closed by a stopper *f* of cork or other material. The center of this stopper was provided with an axial opening *g* which was closed by a wooden peg **G**, the lower end of which was pointed and had a groove that extended up from this point beyond the stopper so that water placed in the fountain could only percolate down through the stopper into the water in the aquarium nearly as fast as the small groove *h* would permit. The upper end of the fountain was closed except for a central opening *k*, and the shaft of peg **G** was extended up through this opening so that it could be manipulated by hand to control the supply of flowing in.

In operation, pebbles or other suitable mineral material were placed in the cage so as to fill it very nearly to the upper end. If desired, aquatic vegetation, as shown in the drawings, could be planted in the cage so that its foliage would branch out into the aquarium and the lower reduced end of the fountain was screwed to the upper end of the cage and closed it. The aquarium having been previously filled with water, the fountain was then filled and the peg manipulated so as to obtain the proper leakage therefrom to maintain the proper level of water in the aquarium and maintain and keep the same pure without changing the temperature. After the tray and the cage had been immersed in the water of the aquarium

for a certain length of time they were apt to become more or less dirty. In this event, the aquarists could grasp the fountain or the cage and lift it and the tray out of the aquarium and then cleanse and replace it without disturbing the fish, which latter are at liberty to swim around the edges of the tray as it was lowered back into the water.

[Figure 58, Ornamental Aquarium, Number 1263391] A more complex and ingenious plant-aquarium combination was patented by Rudolf Eickemeyer, of Yonkers, New York in 1918. There were plant holders on the two short sides of the aquarium and one in the middle (the aquarium had a cylindrical hole for this purpose). One innovation was the light bulb below the center plant holder that was surrounded by a transparent cylindrical screen that rotated via a clockwork mechanism. The screen, which could be changed, was constructed of various colors that imparted a forever changing, colored light show within the aquarium.

Figure 1 is a longitudinal sectional elevation of an aquarium; the section in this figure is taken on the line **1 - 1** of Fig. 2. Fig. 2 is a plan view of the structure shown in Fig. 1, the upper part of which is shown in section, the view in this figure being taken on the line **2 - 2** of Fig. 1. Figs. 3 and 4 are sectional plan views of portions of the structure shown in Fig. 1, these sections being taken respectively on the lines **3 - 3** and **4 - 4** of Fig. 1. Fig. 5 is a longitudinal sectional elevation of a modified structure made in accordance with this invention. Fig. 6 is a plan view of the structure shown in Fig. 5. Fig. 7 is a sectional elevation of a portion of a structure somewhat similar to Fig. 5, but illustrates a modified form of construction. Figs. 8 and 9 are respectively a plan view and a sectional elevation of another form of my improved aquarium. Figs. 10 and 11 are plan views of still further forms of construction. In Fig. 12 the invention is shown in a structure modified into such a form that an aquarium could be used as a chandelier and Fig. 13 is a plan view partly in section of the central portion of the structure of Fig. 12.

In the structure shown in Figs. 1-4, **10** designated the body or water receptacle portion of an aquarium.

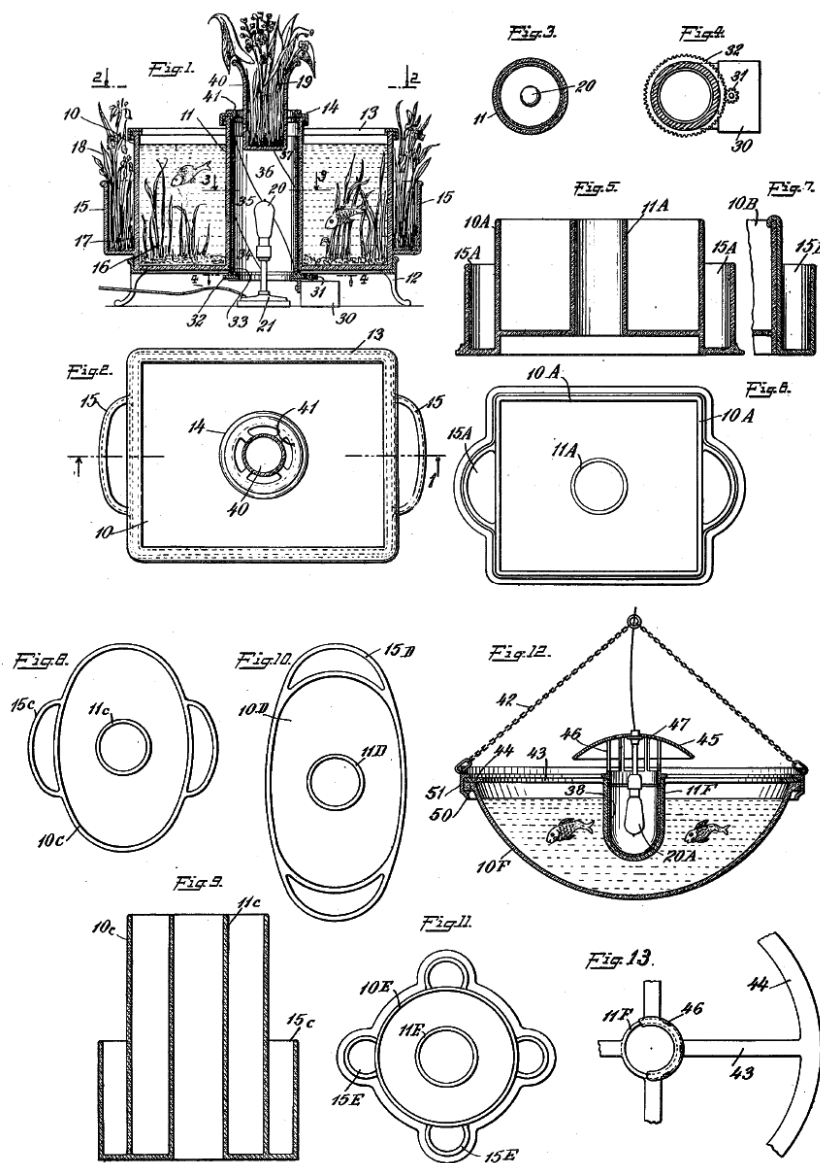

Figure 58: Rudolf Eickemeyer's plant and aquarium combination, 1918.

This, as shown, was constructed with a central portion 11 which formed a cylindrical open-ended chamber within the receptacle. This structure was designed to rest upon a metallic ornamental base 12 and could have a metallic rim 13 around the upper edge of the receptacle 10 and a metallic rim 14 around the upper edge of the cylindrical walls 11. 15 - 15 are side pockets of glass or other suitable transparent material which in this case were cast integrally with the receptacle 10 at the ends and, as shown in Fig. 1, of less height than that of the receptacle 10. 20 is a lamp, in this case an ordinary incandescent lamp mounted in a standard 21 that was of such pro-

portions as to cause the lamp 20 to extend into the cylindrical chamber intermediate the bottom of the receptacle 10 and the upper surface of the water therein. 30 designates a casing in which is a motor, for example a clockwork mechanism by means of which a pinion 31 is rotated. 32 was a gear in mesh with this pinion, the upper surface of which was constructed to form an annular groove 33 in which could be placed a cylindrical transparent screen that by means of the motor mechanism could be rotated within the cylindrical chamber formed by the partition walls 11. This transparent screen was constructed of a number of portions 34-35-36-37 of different colors that could be joined together along spiral lines as shown. 40 was a vase provided with a spider-like flange 41 adapted to rest upon the metallic rim 14 without obstructing the free passage of air up through the cylindrical chamber in which the light 20 was placed. In the form of aquarium illustrated in Fig. 1, certain aqueous plants, such as are commonly used in aquariums, are shown at 16. In the side pockets 15, a certain amount of soil is shown at 17 with plants 18 growing therein. Similarly, plants 19 are shown in soil contained within the vase 40.

In the form of construction shown in Figs. 12 and 13 the main receptacle is designated by 10^F and the walls of the light chamber by 11^F. In this case the aquarium proper was made in the form of a bowl and the light chamber was closed at the bottom but yet was within the main receptacle and was for the same purpose of providing an air space for a lamp inside of the water and fish receptacle. The bowl was constructed with an enlarged rim 50 around which was fitted an annular metallic structure 51 to which chains 42 were attached at intervals. By means of these chains the structure could be suspended from a ceiling or other overhead structure.



PROHIBITION: THE DECADE OF 1919-1928

[Figure 59, *Aquarium*, Number 1322322] This decade was also a time for many design patents. We'll begin with the more utilitarian ones, starting with the frameless aquarium construction patent in 1919 by William Mack of New York City. This was the first design to use waterproof cement to seal the glass joints, although strength was achieved by using L-shaped metal brackets fastened with bolts through holes drilled through the glass. There was no doubt that this was a strong aquarium, but the nature of the

“waterproof” cement was not specified so it is not known how long a tank would remain leak-free with the available cements of the day. Figure 1 is a perspective view of the aquarium, Fig.2 is an enlarged sectional perspective view of a portion of the aquarium and Fig. 3 is a sectional plan view of the corner fastening for fastening the ends of adjacent sides together.

The one-piece supporting frame **10** of the aquarium was of metal, rectangular in shape. The frame was provided at its outer margin with a supporting annular flange from which extended outwardly an annular ledge **12** provided at the corners with legs **13** for supporting the aquarium on a stand, table or other suitable support. On the frame **10** rested a bottom **15** and on the ledge **12** rested the sides **16**, the bottom **15** and the sides **16** being made in the form of glass plates. The ends of adjacent sides abutted one against the other, and the lower portions of the sides abutted with their inner faces against the annular flange **11** and against the edges of the bottom **15**.

In order to fasten the lower portions of the sides **16** to the frame flange **11**, use was made of angle or corner clips **20**, one for each corner and fitting exteriorly on the end portions of adjacent sides **16** and the flange **11** to fasten the parts together (see Fig. 2). Similar angle or corner clips **25** fitted exteriorly against the ends of adjacent sides **16** near the upper ends and the clips were fastened to the sides by bolts **26**. The aquarium could be readily assembled and securely fastened in place without the aid of highly skilled labor. In order to render the various joints watertight and to allow expansion and contraction of the parts without opening the joints, use was made of waterproof cement interposed between the bottom edges of the sides **16** and the ledge **12**, between the

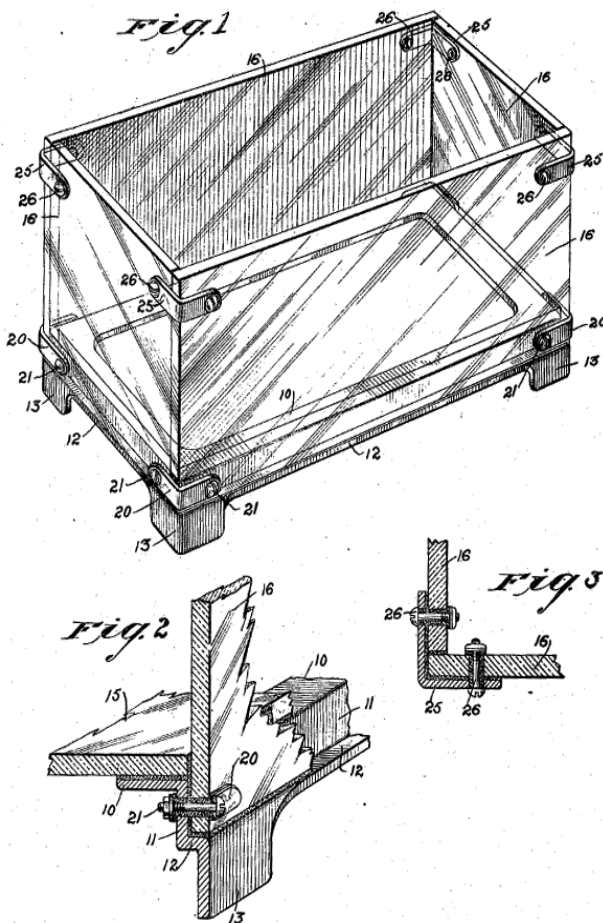

Figure 59: William Mack's
aquarium construction patent, 1919.

inner faces of the sides 16, the flange 11 and the edges of the bottom 15, between the bottom 15 and the frame 10, between the abutting ends of adjacent sides and between the clips 20 and 25 and the outer faces of the sides 16. The bolt holes in the sides 16 and flange 11 were filled with a cementitious substance to prevent direct contact of the metal parts with the glass parts and thus compensated for the unequal expansion and contraction of the metal and glass parts.

[Figure 60, *Aquarium Structure, Number 1432827*] The 1922 patent of August G. Bauer of Columbus, Ohio showed a framed aquarium that somewhat resembled those familiar to aquarists of the 1950's and 60's, although the angle-iron frame was bolted together, not spot-welded. The base was made of reinforced concrete, a definite hazard to those prone to hernias, but admittedly as strong as it gets!

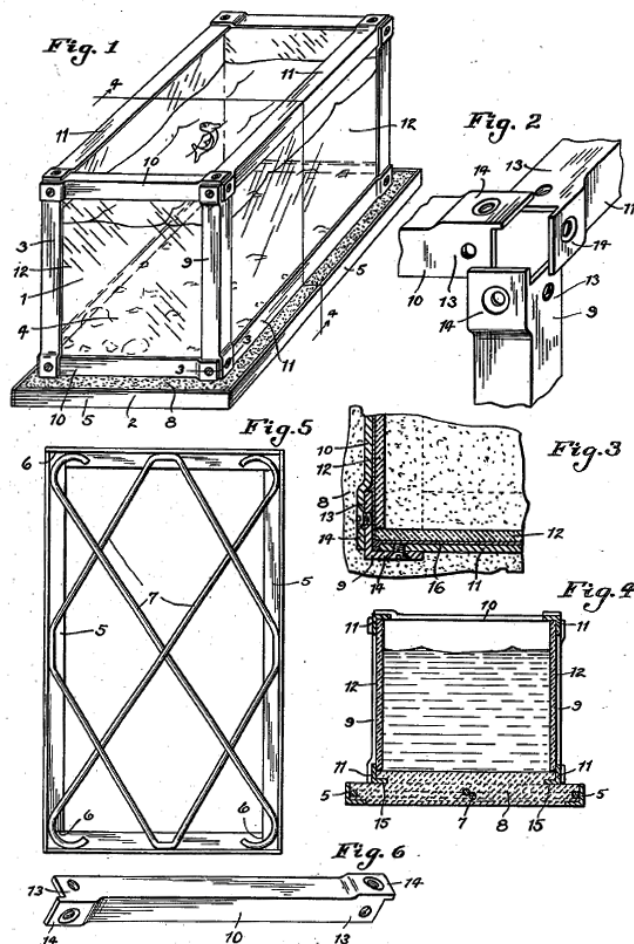

Figure 60: August G. Bauer's aquarium construction patent, 1922.

Figure 1 is a perspective view, Figure 2 is a detail perspective view of the adjoining or meeting ends of the frame member, Figure 3 is a horizontal sectional view taken through said member on the plane indicated by the line 3 - 3 of Figure 1, Figure 4 is a transverse vertical sectional view taken along the line 4 - 4 of Figure 1, Figure 5 is a plan view of the base reinforcement and Figure 6 is a perspective view of one of the angle iron sections.

1 designates the aquarium in its entirety. Essentially, the structure consisted of a base 2, a vertically arranged superposed frame 3 and a transparent panel construction 4 capable of being retained in position by reason of the arrangement of the base and frame. The superposed frame 3 consisted of suitably united vertical, transverse and longitudinally extending angle iron sections 9, 10 and 11 respectively, that were adapted to have their meeting or adjoining ends securely united together to produce a substantially rectangular frame. This frame was adapted to retain the transparent sides 12 of the aquarium and to secure the latter together so that their displacement would be eliminated and undue seepage of fluid from the tank prevented.

The frame 3 was substantially embedded in the concrete base 2. Thus when the base was initially formed, concrete was poured in to a level substantially equaling the height of the upper edges of the members 5. Following this the frame was placed upon the base so that the lower of the transverse and longitudinally extending sections 10 and 11 could rest upon the upper surface of the base end formed. Following the position of the frame, the base was further built up by pouring concrete into the frame until the lower of the sections 10 and 11 were filled. By this arrangement the base when completed would be provided with a rectangular recess 15 in which the horizontal legs of the lower sections 10 and 11 would be received, embedded and firmly retained against undue movement. Following the erection of the sections 9, 10 and 11, the transparent sides 12 were positioned within the frame and were adapted to be retained therein by means of cement or other suitable adhesive 16. The latter was distributed around the inner surfaces of the sections 9, 10 and

11, and served to securely unite the panels 12 with the inner surfaces of the sections. The panels were situated so that their vertical edges were enabled to abut one another, and by the employment of the adhesive this relationship was maintained, a feature that resulted in enabling the tank to retain and hold a liquid without undue loss or seepage.

[Figure 61, Aquarium, Number 1571196] Wladyslaw Galant of Chicago designed an aquarium in 1926 that had an all-metal frame. However, like many older aquariums, a top frame was absent so the glass edges at the top had to be polished for safety. As in the first American aquarium patent, to minimize leakage there were external L-shaped flanges and flat internal ones fastened together with lugs attached to the outer flanges. The base was made of wood, but it was glazed and covered with glass so the wood never came into contact with water. A pipe for water entry was located in the bottom of the tank.

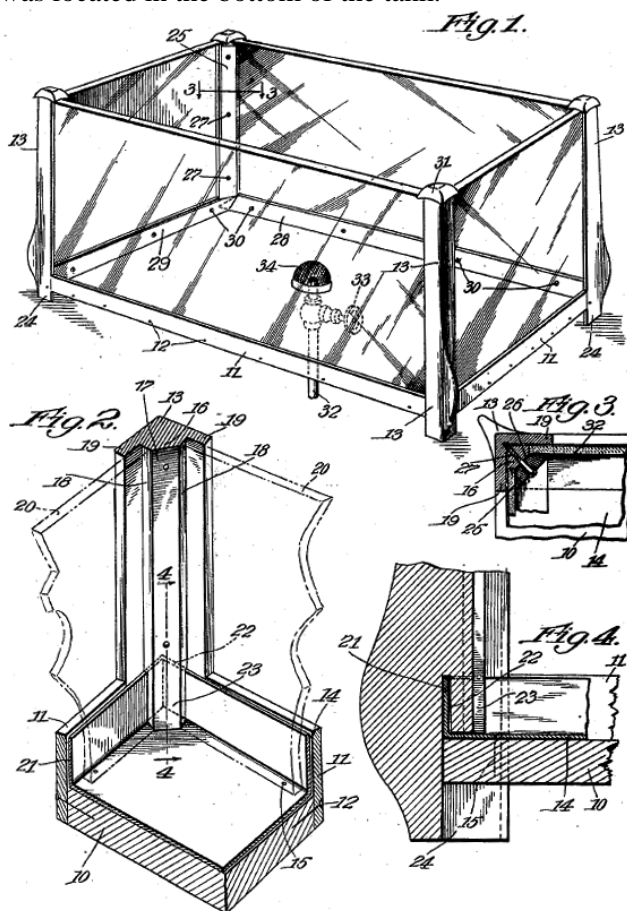

Figure 61: Wladyslaw Galant's aquarium construction with a water entry in the bottom, 1926.

Figure 1 is a perspective view of the aquarium, Figure 2 is an enlarged view partly in elevation and partly in section showing the corner construction of the invention, Figure 3 is a plane cross sectional view of the corner of the device taken on line 3 - 3 of Figure 1 and Figure 4 is a vertical cross sectional view 45 taken on line 4 - 4 of Figure 2.

The invention consisted of a wooden rectangular base 10 with side ledges 11 attached by any suitable means, such as nails 12. The adjacent ends of the several ledges did not meet at the corners of the base, but were spaced permitting the insertion of vertically positioned corner members 13 that were likewise attached to the base. A metal tray 14 placed upon the base was held within the ledges and the corner members. If necessary to prevent any shifting of the tray 14 upon the base during the process of assembling the several parts of the aquarium, the tray could be affixed by its bottom to the base by means of nails 15. The nails were driven in the tray at points that subsequently would become covered by the glass walls later described so as to eliminate any possibility of leakage.

[Figure 62, Process and Device for Regenerating Water of Aquaria, Number 1574783] An aeration patent was obtained in 1926 by Evert W. Beth of The Hague, Netherlands. Two versions are shown in the drawing, with Beth preferring the second one, although the underlying principle was the same. Beth claimed that it would remove carbon dioxide and add oxygen to the water, which it did, but it also had the advantage of circulating the water since it drew the tank water from the bottom. These were simple but effective devices, but since they were typically made of glass they were fragile.

Fig. 1 shows a vertical section of a first embodiment and Fig. 2 a vertical section of the preferred embodiment of the invention. 1 is the tube for admitting the compressed air, which should be at a pressure of about 2 atm. The exhaust opening of this tube ended in the lower part 3 of a second tube 4, reaching from a short distance of the bottom 2 of the aquarium until above the water level 5. The tube 4 was provided with an exhaust opening 6 situated between the water level and the top of the

tube. The last mentioned tube could, according to the first embodiment, be lowered or raised in order to be applicable to aquaria of different depths.

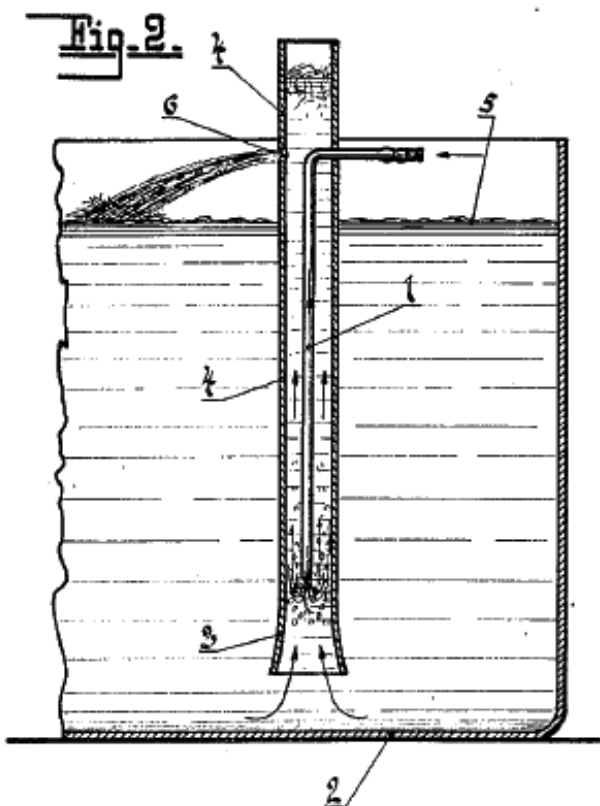
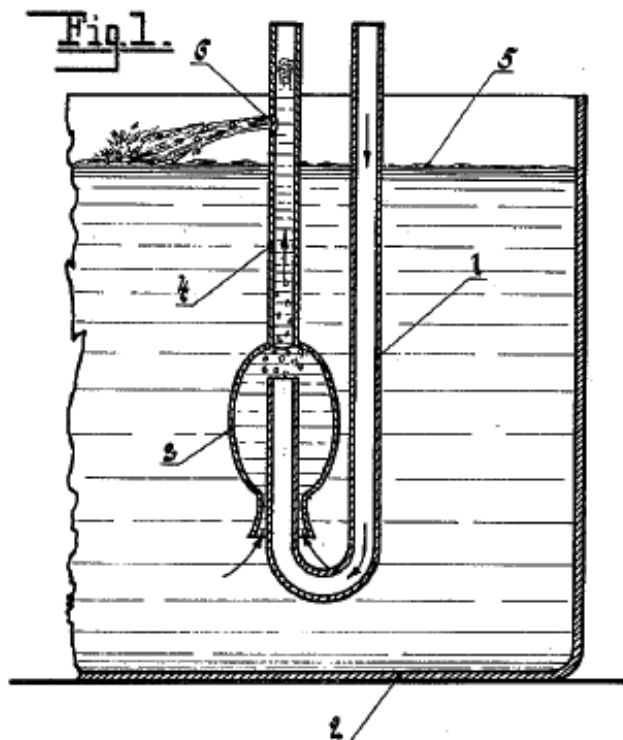

Figure 62:
Evert W. Beth's aerators, 1926.

When air was admitted in the tube 1, an ejector action took place in the lowermost part 3 of the degassing tube and water was drawn out of the aquarium and conveyed by and with the air in the tube 4 until beyond the opening 6. Combustion took place in the tube 4, where carbonic acid was formed at the expense of the oxygen of the air. As a consequence of the column of water formed above the opening 6, the regenerated water was expelled with force through the opening, whilst the excess of air and the noxious gases escaped in vertical direction, thereby breaking their way through the column of water situated above the opening 6. This was the cause of the continual up and down movements of the water column during the working of the device. The regenerated water ejected back into the aquarium and through the air had ample opportunity to fill up its grade of oxygen. Moreover, the drawing of water at the bottom 3 of the tube 4 created a uniform circulation.

The preferred embodiment shown in Fig. 2 was even more simple of construction on account of the air tube 1 being adapted in the inside of the tube 4 and provided with a mouthpiece extending outside the surrounding tube. At the underside, the air tube ended at a convenient distance from the lower extremity of the degassing tube 4. The invention had the advantage that the composition of the water remained unchanged (excepting of course its growing richer in oxygen and poorer in nitrogen) and that the infusoria were not kept back or killed but thrived in their natural state, thus providing plenty of food for the microscopic creatures. The result of the process was that plants as well as the creatures remained perfectly healthy and grew and thrived in the same way as in their natural state when kept in water treated according to the invention.

[Figure 63, *Aquarium*, Number 1444367] Two breeding cages were patented during this decade, the first in 1923 by Clara Brown Collamer of Fort Collins, Colorado, the first woman to receive a U.S. aquarium patent. However, it was more of a brooding cage to protect young fish (especially trout) than

a traditional livebearer breeding cage. The cage had floats on both of the small ends, and the screens could be replaced with others of different mesh sizes to suit the fish the device was protecting.

Figure 1 is a side elevation, partly in section, showing an aquarium constructed in accordance with the invention. Figure 2 is a central vertical longitudinal sectional view, Figure 3 is a horizontal section as indicated by line 3 - 3 of Fig. 1, Figure 4 is a vertical transverse sectional view as indicated by line 4 - 4 of Fig. 1 and Figure 5 is a duplicate of Fig. 4 with the exception that it illustrates the manner in which larger screens are used.

1 designates a preferably rectangular tank constructed of any suitable material, the tank being equipped near its upper edge with floats 2 for supporting it at a predetermined depth in a body of water, the arrangement of floats being such that the upper end of the tank extended above the water level to admit air through a screen or other suitable open work top 3.

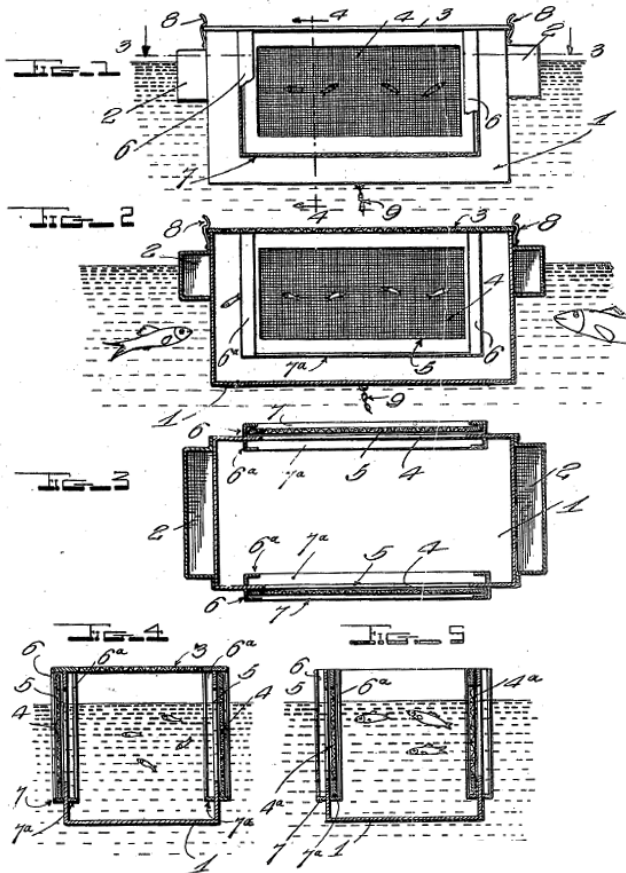

Figure 63: Brolliar B. Collamer's Breeding Cage, 1923.

One or both sides of the tank could be provided with a screen or screens such as those indicated at 4, each screen serving to admit water through an inlet opening 5, but acting to prevent the escape of the small fish through this opening from the tank. For holding each screen 4 in place, vertical and horizontal guide strips 6 and 7 respectively were provided that could be secured to the outer side of the tank wall. Each screen 4 was of a rather small mesh, but it was intended to substitute a screen 4^a of larger mesh for each of the screens 4 when the fish had gained sufficient size. To permit the screen 4^a to be inserted before the screen 4 was removed, additional guide strips 8^a and 7^a were provided at the inner side of the tank walls. When screen 4^a was inserted, the screen 4 could be removed as is clear by comparing Figures 4 and 5.

All of the screens were preferably of such height as to permit the projecting edge portion of the top 3 to rest upon, thereby preventing the screens from being accidentally removed. Suitable latches 8 were employed to hold the top in a closed position. The invention was intended principally for use as a trout brooder and could be anchored by means of a chain or the like 9 in any suitable body of water to serve as a container for the young trout until they had reached a size at which they could protect themselves. They were thus protected against being devoured by larger fish, as had often occurred.

[Figure 64, *Live-Bearing Fish-Breeding Device, Number 1552063*] In 1925, a more familiar fish breeding device was patented by Paul O. Kuehn of Pittsburg. The bottom sloping sides had a narrow slit from which the new-born livebearer fry could escape. This was a very practical device and was actually on the market for many years, including post-World War II.

Fig. 1 is an isometric view of the device or cage, Fig. 2 is a side view on a smaller scale, Fig. 3 is an end view and Fig. 4 is a top side view. In the drawings, 5 indicates the parallel vertical side walls of the device, and 6 were the vertical end walls. The top of the device was substantially rectangular in shape. The lower portions 7 of the sides were inclined and converged to form a troughed bottom, a narrow slot 8

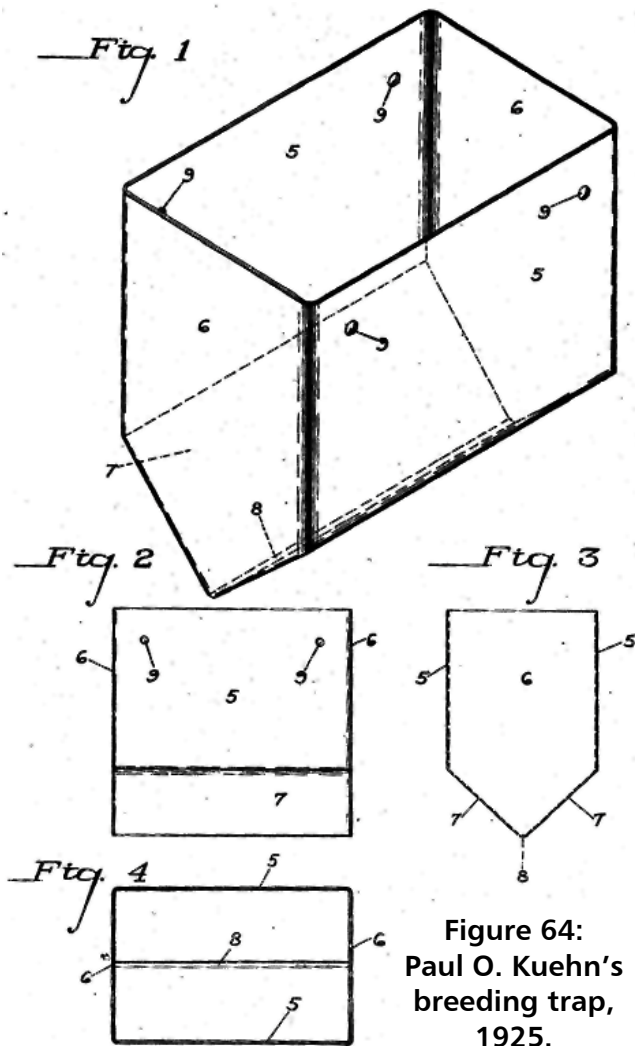

Figure 64:
Paul O. Kuehn's
breeding trap,
1925.

being formed at the point of intersection. The end walls were vertical throughout their height so that the slot 8 was substantially co-extensive with the length of the device. In the walls 5 at any suitable points were openings 9 through which hooks or other suspending means could be passed to suspend the device in an aquarium or tank with the top of the device above the water line of the tank. The device was formed entirely of glass, and was so shaped that it could be readily molded in a single operation.

In use, the device was suspended in a tank or aquarium with its top above the waterline of the aquarium. The parent fish were placed in the cage and as the young were born, they sank down and were directed by the sloping bottom walls through the elongated slot 8 into the aquarium. The parent fish were confined, however, so that they could not escape and devour the young. The elongated slot provided ample

space for the escape of the young and would not readily become stopped up.

[Figure 65, *Aquarium*, Number 1444367] The next shipping container design appeared in 1927, that by Frank L. Holman of Minneapolis, Minnesota. In this variation on a well-known theme, the air or oxygen bottle was positioned below the can. An internal spiral ring with many holes distributed the gas evenly throughout the can. Unlike Remsburg's 1907 design, Holman did specify that the cover was perforated so that the excess gas could escape.

Figure 1 shows a vertical section through the novel container; and Figure 2 is a transverse sectional view on the line 2 - 2 of Figure 1 and shows the discharging coil. The container consisted of a sheet metal

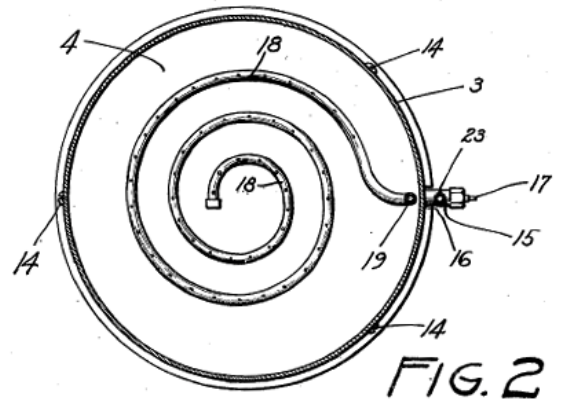
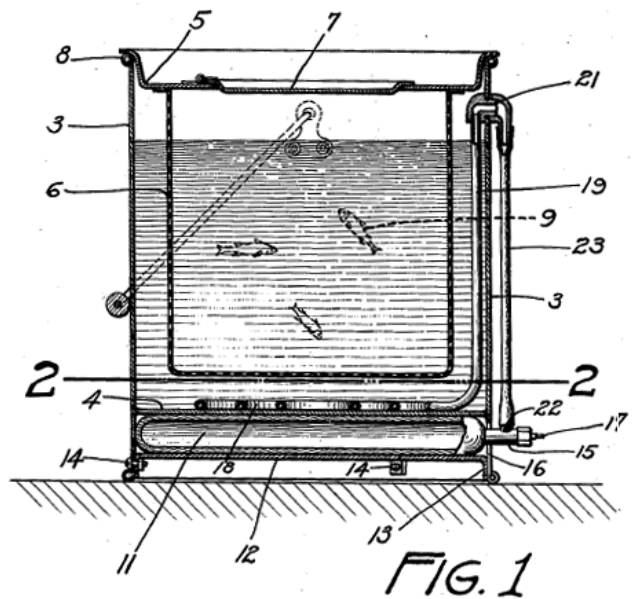

Figure 65:
Frank L. Holman's shipping can, 1927.

casing 3 that was preferably circular in form or it could be made of other shapes. The bottom 4 of the casing was preferably spaced above the lower end of the cylindrical casing. The cover 5 of the casing was of the usual form and had secured to it a hanging perforate element such as the usual screen 6. This cover was provided with an opening that could be closed by the hinged plate 7 mounted on the cover. The cover was outwardly flared and was supported by the rolled upper ends of the case. In use, the casing was filled with water, substantially to the level shown in the accompanying drawing, and live fish were adapted to be placed in the perforate element and confined within the water that could circulate through the perforate element from the surrounding parts of the casing.

A base plate 12 was provided with a peripheral downwardly turned flange 13 that could be secured to the lower end of the case by any suitable means such for example, as the bolts and nuts 14. The tank 11 had a valved neck 15 that could be inserted through a slot 16 longitudinally extending upwardly from the lower end of the casing 5 as shown in Figure 1. This neck was provided with a valve 17 by means of which the flow of gas under pressure from the tank could be controlled.

[Figure 66, *Design for a Combined Bird-Cage and Aquarium, Number D53157*] The bird cage aquarium had not died out just yet, as evidenced by the patent obtained by Andrew Syrocki of Detroit, Michigan in 1919. This consisted of a bird cage at the top situated over a lamp, followed by a tray where holders could be placed in the corners, then the aquarium itself, followed by an open shelf with circular cutouts in three of the four sides. To top it all off, the drawing shows three flags stuck into the top of the bird cage. The only thing Syrocki left out was a phonograph playing the Star Spangled Banner! Since this was a design patent, there is no description so we do not know how the tank was accessed but I imagine that the shelf containing the lamp and birdcage could be lifted off for this purpose. This is one of the problems often encountered with design patents, i.e., the reader is forced to guess how things were supposed to work. Figure 1 is a perspective view of the bird cage and aquarium as viewed from one direction and Figure 2 is a perspective view of the same viewed from the opposite direction.

[Figure 67, *Fish Bridge, Number 1576462*] The year 1926 saw the second patent issued for a fish bridge (earlier, one was incorporated into Palen and Sexton's bird cage aquarium of 1878). This was issued to Herman A. Polzin of Chicago and was a much simpler design since all one had to do was to fill the bridge with water, cap the ends temporarily and then insert both ends into the two tanks and remove the caps. Polzin stated that it "...can be used for ornamental or advertising purposes in connection with aquariums." The inventor evidently actually built the bridge since he explained that he cleaned the tube by filling a cloth bag with ground lead and sliding it back and forth in the tube. He also described his fish chasing each other back and forth through the bridge so I assume that it was made of glass, although Polzin did not specifically identify the material.

Fig. 1 is a plan view of one form of the invention, Fig. 2 is a side elevation of the same, Fig. 3 is a sec-

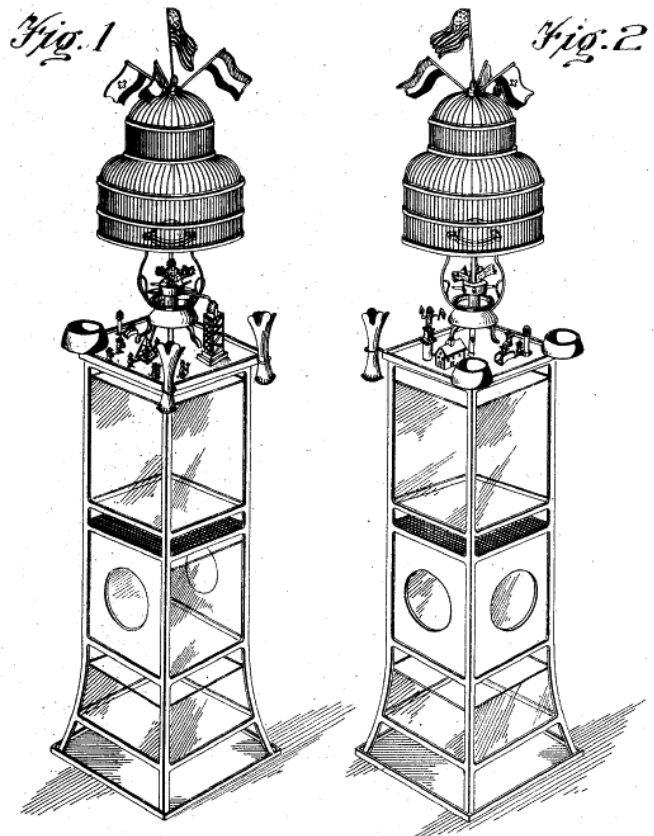

Figure 66:
Andrew Syrocki's birdcage aquarium
Combination, 1919.

tional view illustrating in detail the supporting means, Fig. 4 is a sectional view of a portion of one of the legs of the bridge provided with the cap for filling, Fig. 5 is a sectional view taken substantially on line 5-5 of Fig. 4, Fig. 6 is a view in elevation of another, type of bridge and Fig. 7 is an elevation of another form of bridge. In one embodiment of the invention shown, 1 and 2 represent receptacles, bowls or aquariums of suitable size, shape and material and provided with such accessories as could be desired and that are usually found in aquariums.

Connecting the two receptacles was a bridge 3 that was provided with two legs 4 adapted to be positioned one in each receptacle below the water level, the connecting portion between the legs being of such form or shape as was desired. In use the bridge was filled and contained water so that there was formed a water bridge or connection between the two

receptacles through which the fish could pass over. In the particular type of bridge shown in Figs. 1 and 2, a loop 5 was formed between the two legs thereby increasing the distance of travel between the two aquariums and producing an attractive appearance.

A very simple, attractive and convenient adjustable support was shown and illustrated in Fig. 3. It provided a clamp consisting of cooperating and similar mating members 7 and 8 that could be secured together by bolts or screws 10 or equivalent means for the purpose. The two members were arranged to fit the legs 4 and corresponded in contour with the contour of the leg. If desired, and it was generally preferred, there could be provided a rubber or like gasket 11 on each clamp so as to give a good fit and prevent sliding of the clamp on the leg. Each clamp part was provided with a socket 9 in which could be inserted a rod 12, one at each side. Each rod had a

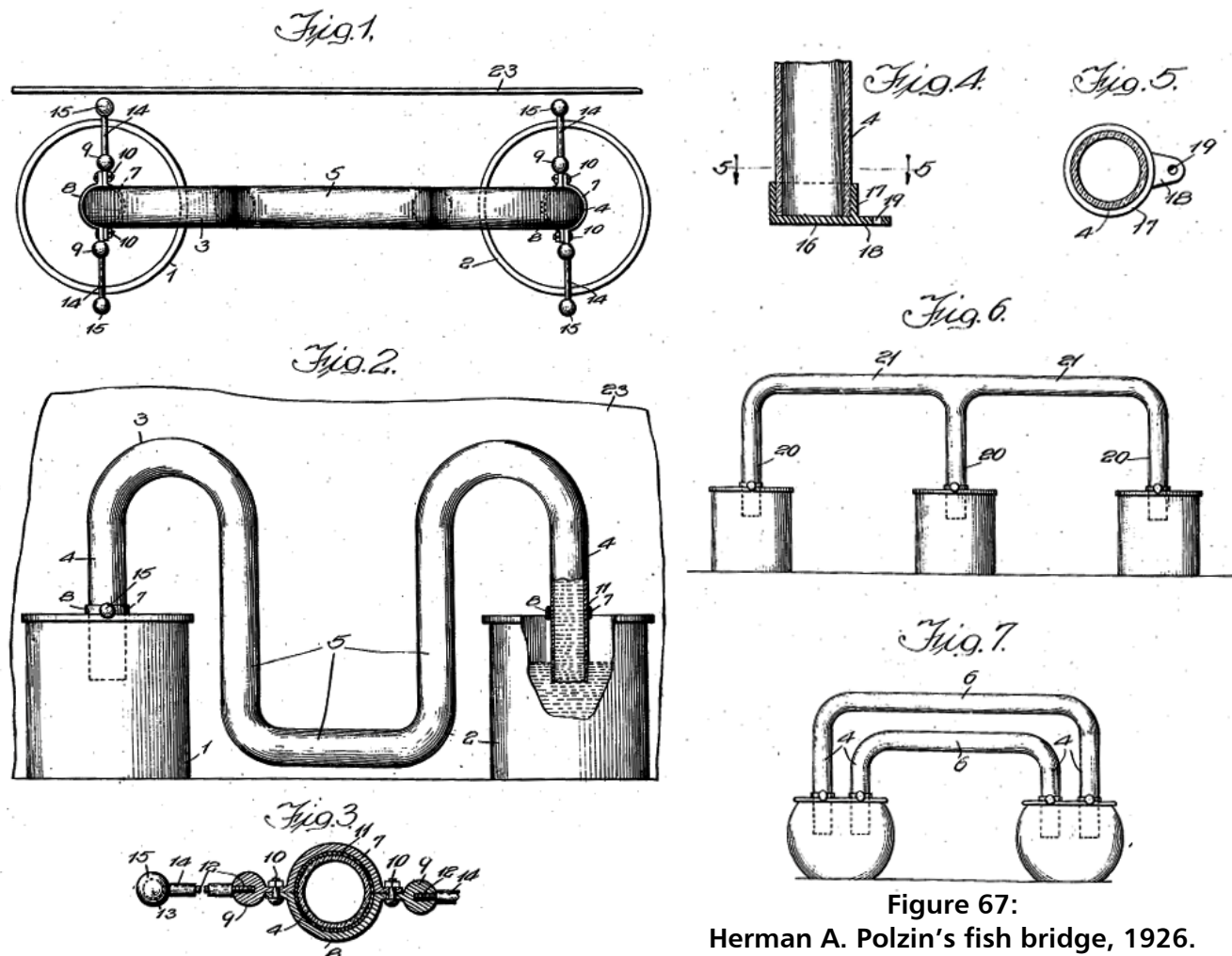

Figure 67:
Herman A. Polzin's fish bridge, 1926.

threaded engagement in the part 9 so that it would be securely locked in place.

To facilitate filling the bridge with water at such times as was desired, as for example when changing the water in the aquarium, caps 16 were provided of soft rubber and with the flange 17 adapted to fit over the end of the leg. In this manner the bridge could be completely filled with water and the ends capped and inserted in the receptacles below the water level without losing any water and then the caps removed. Each of the caps were provided with a lug 18 having a hole 19 through so that a string or the like could be employed to secure the cap to the bridge or to the end of one of the arms 12 or to permit its being hung up. The caps were only employed when it was desired to remove the bridge or to replace it; at other times the ends of the bridge would be open.

Fig. 6 shows how more than two aquariums could be connected by a single bridge. In this case 20 represents the depending legs adapted to project into the water in the aquarium and 21 the connecting portions. Of course, a plurality of aquariums could be connected by bridges similar to that shown in Fig. 7 or in Figs. 1 and 2, and while three connected by a single bridge are shown, obviously any number could be so connected.

[Figure 68, *Flower Box and Fish Bowl*, Number 1641496] A hanging aquarium that combined both a fish bowl and a flower box was patented by Alphons M. Kuhl of Omaha, Nebraska in 1927. In overall appearance it was a hanging flower box with a fish bowl added as an afterthought. The bowl was attached to the flower box with setscrews, much in the manner that a light bulb shade is fastened today. This was really a disastrous design since the bottom of the flower box had screened apertures so that the surplus water from the flower box passed directly into the aquarium, adding all sorts of unwanted – and perhaps toxic – material to the fish bowl. Furthermore, access to the aquarium was impossible unless one removed the set screws that held it to the flower box. Removing a light bulb shade that uses set screws without breaking anything is iffy; removing a fish bowl full of water and fish in this way is a real challenge!

Figure 1 is a perspective view of the flower box and fish bowl, Figure 2 is a vertical transverse sectional view through a lower portion of the flower box, the bowl supporting ring and a portion of the bowl and Figure 3 is a bottom plan view of the bowl ring.

The numeral 1 designated a rectangular shaped flower box for the reception of a flower pot, the opposite sides of which were provided with upwardly extending arms 2 that adjacent to their upper ends were outwardly curved at 3 and then terminated in inwardly converging arms 4 to the upper ends of which were connected supporting chains 5. The supporting chains converged upwardly and inwardly and were connected to a plate 6 that could be attached to a wall in any suitable manner. The plate formed a support for an electric lamp 7 and the curved portions of the arms had attached electric lamps 8 that extended downwardly and outwardly; therefore the flower box

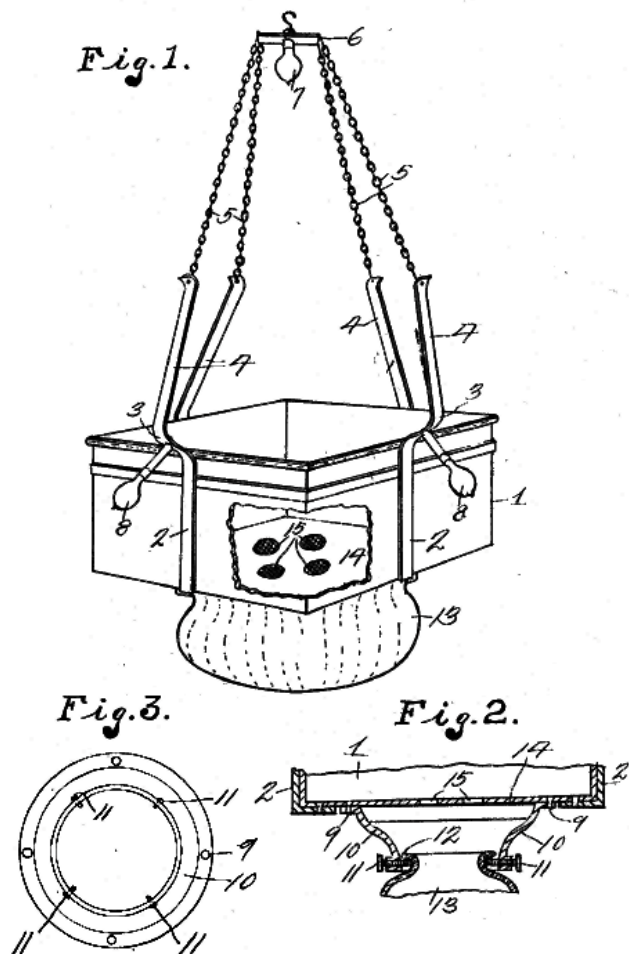

Figure 68: Alphons M. Kuhl's hanging aquarium and flower box, 1927.

was supported by the chains and the chains and arms formed an ornamental structure for the flower box.

Secured to the underside of the flower box **1** by means of rivets **9** was an annular bowl holder **10** provided with set screws **11** that engaged under the flange **12** of the fish bowl and securely attached the bowl **13** to the flower box and supported the fish bowl, so that persons passing under it could observe the fish within the bowl. At the same time the bowl was supported in a position where any danger of it being knocked over or broken was eliminated. The bottom **14** of the box **1** was provided with screened openings **15** through which water would drain from the flower box and at the same time sufficient air would pass to the water within the bowl to replenish the oxygen as it was consumed, thereby insuring a constant supply of air to the fish through the medium of the water. This invention was simple in construction and could be suspended from an overhead support. It presented an ornamental appearance, especially when flowers were in the box and goldfish were in the bowl.

[**Figure 69, Fish Bowl or Similar Article, Number D76252**] Designs for fish bowls were common in this decade. However, the fish bowl patented in 1928 by Thomas W. McCreary of Monaca, Pennsylvania had more facets to it than an engagement ring, and I'm a bit skeptical whether the fish could actually be seen in such a bowl.

[**Figure 70, Aquarium, Number 1620006**] There were two designs for flat-sided aquariums in this

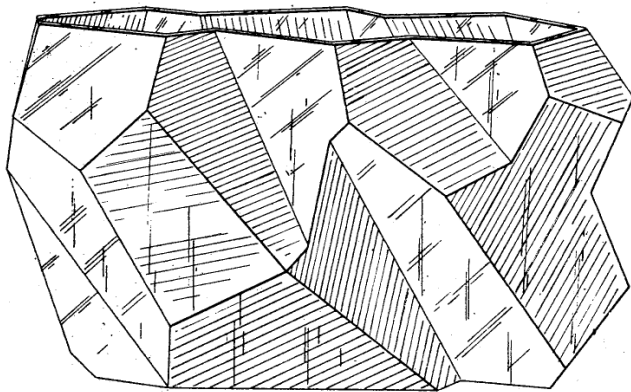

Figure 69: Thomas W. McCreary's many-faceted fish bowl, 1928.

decade, the first by Leslie H. Burlin of Chicago in 1927. Burlin's design was shaped like a World War I army water canister, round in shape but flattened with an opening at the top for access to the fish. It was provided with rings for "...convenient handling..." but since these could not be used for hanging it on a wall, one envisages it rolling along the table and falling off onto the floor! Fig. 1 is an elevation of an aquarium of the drum type embodying the present invention, Fig. 2 is a top plan of the same, Fig. 3 is a detail transverse section on line 3 - 3, Fig. 2 and Fig. 4 is a detail longitudinal section on line 4 - 4, Fig. 2.

The annular shell or body member **1** of the aquarium was formed as a split ring of plate metal, with each of its ends formed with an annular receiving channel for the reception of the marginal portion of one of the transparent end heads or members **2** of the aquarium. Each of such channels were formed by a split bead formation comprising a split out turned annular web **3**, a like split annular intermediate web **4** and a like split in turned web **5**, with such parts integrally formed on the respective ends of the annular shell or body member **1**, by the usual metal rolling or beading operations. The receiving channels formed as above were of a size a degree larger than the size of the marginal portions of the transparent heads **2** which they were intended to receive so that an intermediate filling **6** of elastic packing or composition could be used as a setting for the heads **2** in the attainment of an effective water tight joint between the parts or elements.

[**Figure 71, Fish Bowl or Similar Article, Number D77018**] A more reasonable design was the attractive flat-side fish bowl by McCreary, patented a little later in 1928 than his multi-faceted bowl.

[**Figure 72, Closure for Fish Bowls or the Like, Number 1674046**] Motogo Jyumi of Oakland, California patented the first closure for a fish bowl. The closures contained a horizontal channel (A) spanning them and open to the atmosphere. Jyumi claimed three advantages for the device: (1) It kept cats from scooping out the fish, (2) it provided channels open to the atmosphere and to the fish bowl for

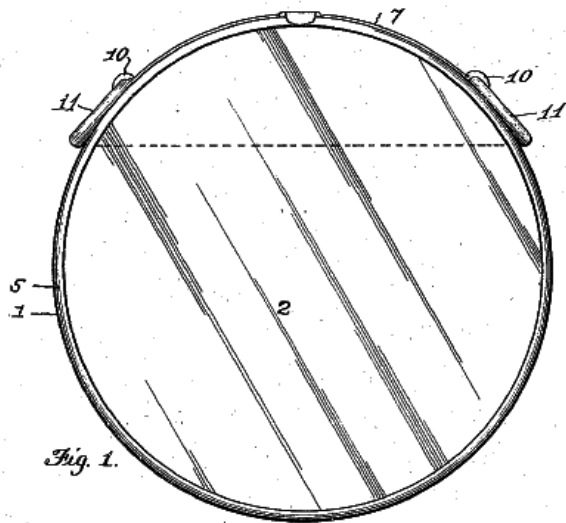

Fig. 1.

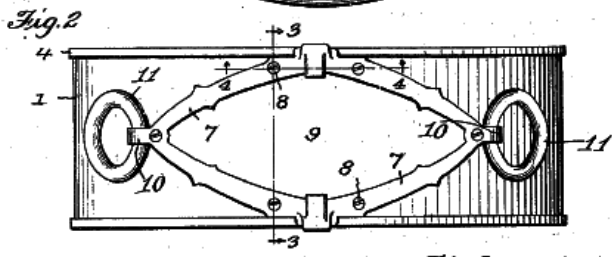

Fig. 2.

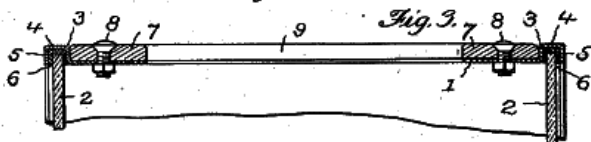

Fig. 3.

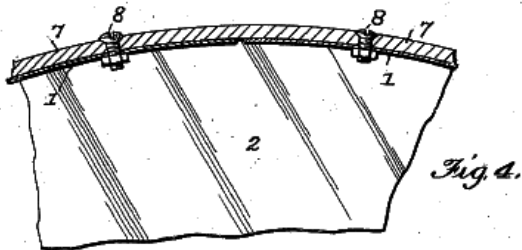

Fig. 4.

Figure 70: Leslie H. Burlin's cannister-style aquarium, 1927.

free circulation of air to the latter, and (3) well, we'll quote Jyumi himself on this point: "The plainness of the wide-mouthed fishbowl in common use is quite marked and in many instances is not in artistic harmony with the surrounding works of art, and, therefore because of this omission of artistic effect they are not in full favor with persons possessing a high degree of esthetic taste." After reading this I realized that my Betta bowl is decidedly out of tune with the Renoir hanging on the wall next to it!

Figure 1 is an elevation of the closure in seated position upon the top of an ordinary fishbowl, the latter

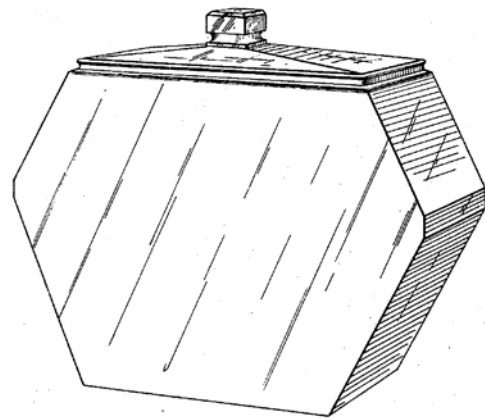

Figure 71: Thomas W. McCreary's flat-sided fish bowl, 1928.

being but fragmentary shown and in section along a median plane thereof; Fig. 2 is a median vertical section through the closure, the section being taken along the line 2 - 2 of Fig. 1.

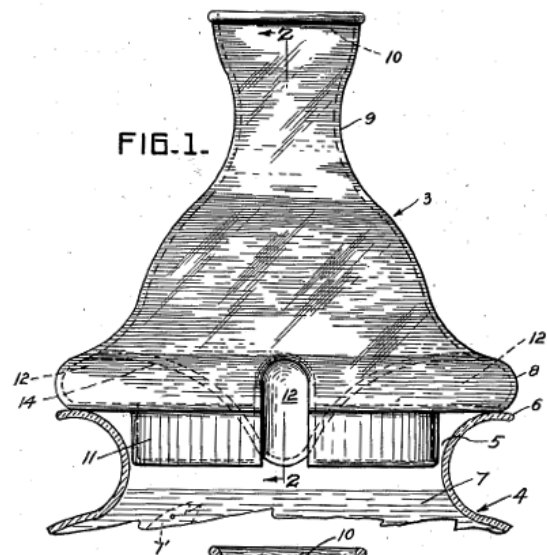

FIG. 1.

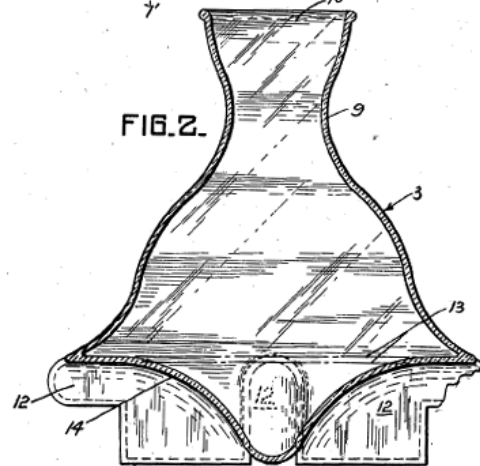

FIG. 2.

Figure 72: Motogo Jyumi's fish bowl closure, 1928.

The numeral **3** indicates the closure. In Fig. 1 it is shown in combination with the usual type of fish-bowl **4** and for which the invention was designed to form a closure. The closure **3** could be composed of glass or other suitable material to harmonize with the objects in view of the purchaser thereof, and was preferably made hollow for the reception of growing plants, cut flowers or other preferred articles.

To meet the necessary requirement for the maintenance of the fish or other animals that could be placed within the vessel but which needed to be in continuous contact with circulating air, such as lizards, frogs, etc. the base **8** and its extension **11** were provided with channels **12**. These channels could radiate from the center of the base to the periphery thereof or be straight and diametrically opposed, as shown by the dot-and-dash lines **13** in Fig. 2. Preferably the closure was provided with a plurality of inverted channels that curve downwardly substantially at its vertical axis as shown in Fig. 2, thus forming a deflecting surface **14** to deflect and direct currents of air **15** passing through the channels into the interior of the vessel, whereby the desired circulation was produced. Channels straight across as indicated by the said dot-and-dash lines **13** could be preferably

desirable in some instances where no water was in the vessel **4** to be aerated.

[**Figure 73, Aquarium and Fountain, Number D53718**] Morris Stein of Philadelphia created two fountain aquarium designs in 1919. This was the first.

[**Figure 74, Aquarium, Number D53719**] The second differed only in the fountain head itself.

[**Figure 75**] The 1926 design of Charles W. Goodsmann of Linnton, Oregon departed from this traditional fountain design and reflected the Art Deco period that started in 1900 and ended in 1930 (*Combination Fountain and Aquarium, Number 1649683*). The basin consisted of three bowls, a large fish bowl and two smaller bowls. In the center column there was an inlet pipe for incoming water and an outlet pipe for overflow water. Above this was an inverted bowl almost the size of the fish bowl, and this was capped off with a smaller inverted bowl. Water was sprayed from nozzles on top of the smaller inverted bowl, the water flowing over the two in-

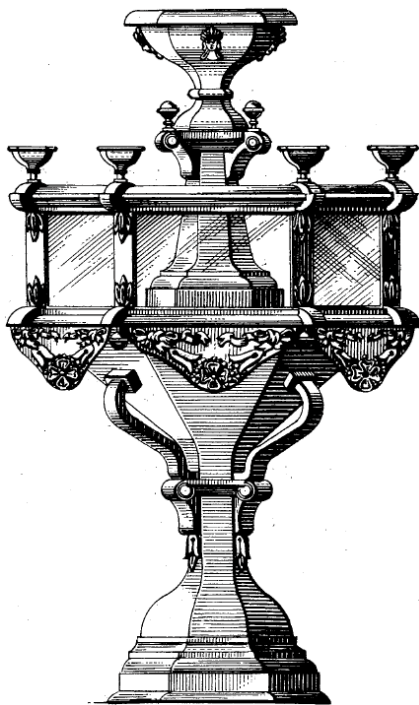

Figure 73: Morris Stein's first fountain aquarium design, 1919.

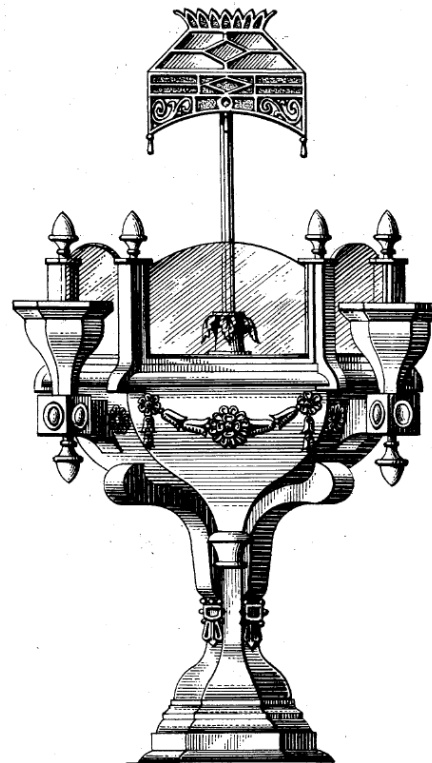

Figure 74: Morris Stein's second fountain aquarium design, 1919.

verted bowls into the fish bowl. Six lamps were located in the bottom of the large inverted bowl and shined their light onto the surface of the water in the main bowl. There were six bull's eyes embedded in the large inverted dome and six in the very top, so light shined out from these locations as well. This must have quite a spectacular fountain, to say the least.

Figure 1 is a vertical section of a combined fountain, aquarium and lily pond embodying the invention, Figure 2 is a horizontal section on the line 2 - 2, Figure 1 and Figure 3 is a top plan view of the shade with its bullseyes and the spray nozzles.

A basin 10 was provided having a suitable base 11 that was entered in the ground indicated at A or on any other suitable support. A neck 12 flared at the upper end rose in basin 10 at the center and had a cylindrical top 13. A tube 14 was placed vertically in the neck 12 and rose materially above terminal 13. To the upper end of tube 14 was secured a dome 15 of a character that reflected light downwardly, the dome being materially larger in diameter than the terminal 13. The dome 15 at the center had a bushing 16 that was threaded or otherwise secured to tube 14. A water supply pipe 17 extended through tube 14 and had a shade 18 at the upper end. Below the shade and of smaller diameter a cup-shaped flange 19 was formed on the dome. The numeral 20 indicates a distributing head 19 on water pipe 17 and from which head extended radial pipes 22 formed with spray nozzles 21. In shade 18 was fitted glass bullseyes 23 that provided color effects to the water sprayed from nozzles 21.

A box 24 was held by its bushing 25 to the tube 14 within the cylindrical terminal 13 of neck 12. Electric lamp sockets 26 were fitted in the top of the box 24 to receive lamps 27. A small tube 28 extended lengthwise in the tube 14 through which tube 28 extended conductor wires 29 extending to the lamp sockets 26. Additional conductor wires passed from tube 28 to the sockets 32 of the lamps within the cup 19. An overflow pipe 33 was provided, having its inlet end 34 at the desired water level of base 10. The above described assemblage was efficient not only as a fountain but for use as an aquarium or lily pond. The water sprayed from the nozzles 21 was spread by shade 18 outward and passed outward of cup 19 onto dome 15. The lamps 31 provided varied light effects on the water below the plane of the shade and lamps

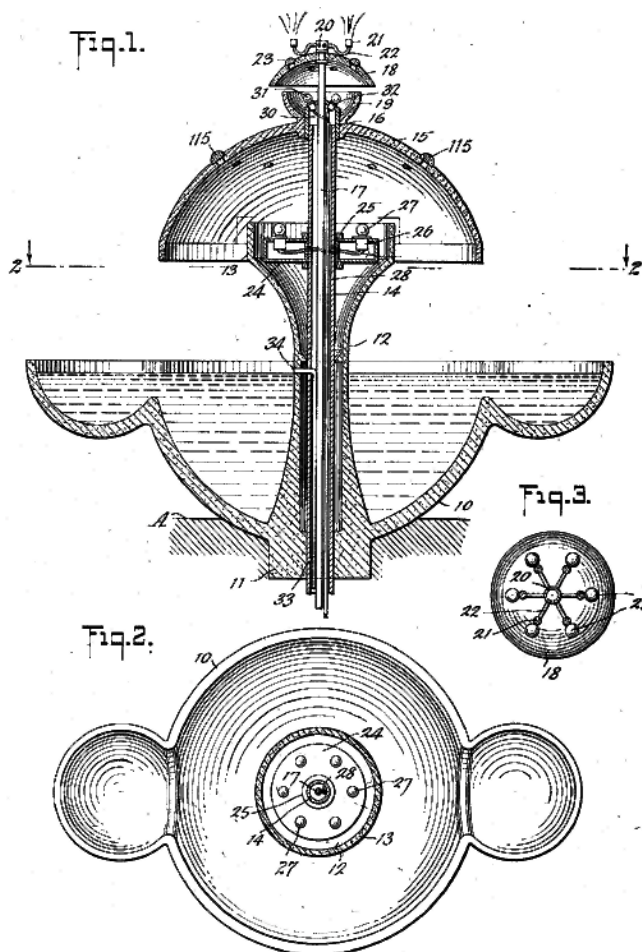

Figure 75: Charles W. Goodsman's complex fountain design, 1926.

27 had a similar effect as the light therefrom was reflected by dome 15. Bullseyes were provided in dome 15.

[Figures 76, *Aquarium Stand*, Number D55751] Aquarium stand designs also proliferated during this decade. The first three - one short stand and two long ones - were patented in 1920 by Frank S. Crowell of Toledo, Ohio and were constructed of ornamental iron. This was the first.

[Figure 77, *Aquarium Stand*, Number D55753] This was the second.

[Figure 78, *Aquarium Stand*, Number D55754] And this was the third.

[Figure 79, *Stand*, Number D64852] A combination patent of jardinière, aquarium and birdcage was

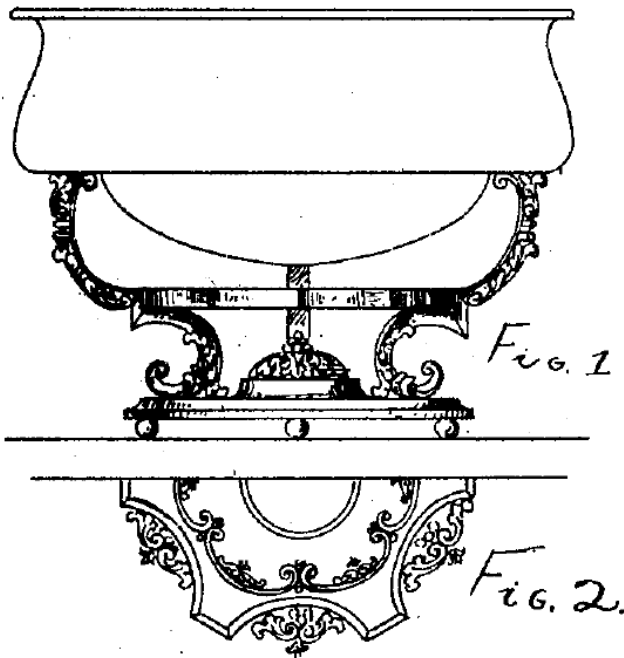

Figure 76: Frank S. Crowell's low stand fish bowl Design, 1920.

assigned to John B. Hue of Tarentum, Pennsylvania in 1925.

[Figure 80, *Stand for Aquarium or the Like*, Number D74902] In 1928, Bernard Tauman of Chicago patented two very interesting stands designed to hold flat-sided aquaria. This was the first.

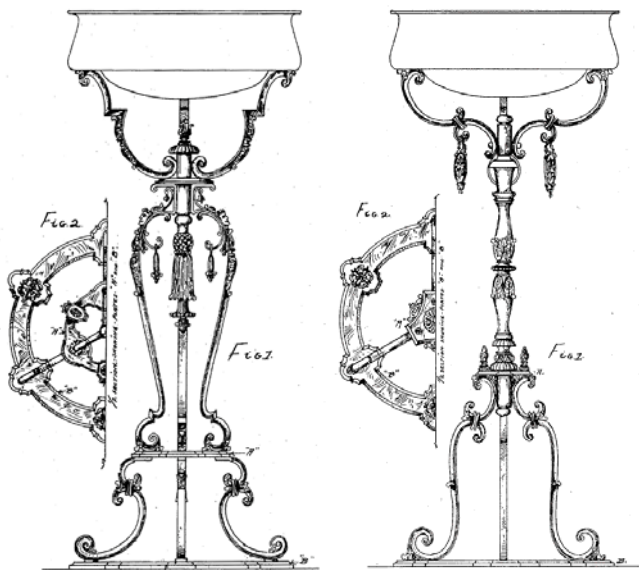

Figure 77: Frank S. Crowell's first high stand fish bowl design, 1920.

Figure 78: Frank S. Crowell's second high stand fish bowl design, 1920.

[Figure 81, *Stand for Aquarium or the Like*, Number D75081] This was his second.

[Figure 82, *Aquarium Stand*, Number D76204] A sleeker design by today's standards was that in 1928 by Richard Rychtarik of Cleveland, Ohio. The problem with many of these aquarium stands, Tauman's in particular, was that in practice they would be top-heavy and very prone to being tipped over, causing a deluge of monumental proportions depending upon the size of the aquarium they supported. Figure 1 is a front elevational view of the stand showing the bowl in dotted lines and Fig. 2 is a top plan view of the stand with the bowl removed.

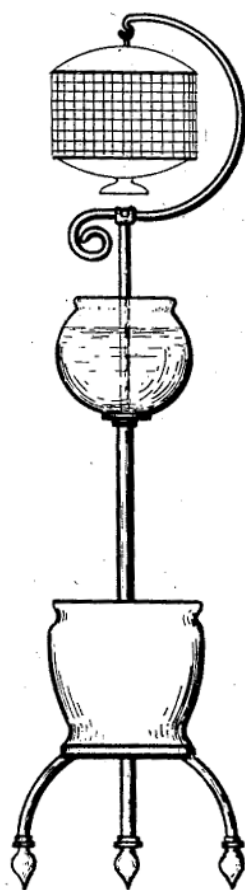

Figure 79: John B. Hue's combination of jardiniere, aquarium, and birdcage, 1924.

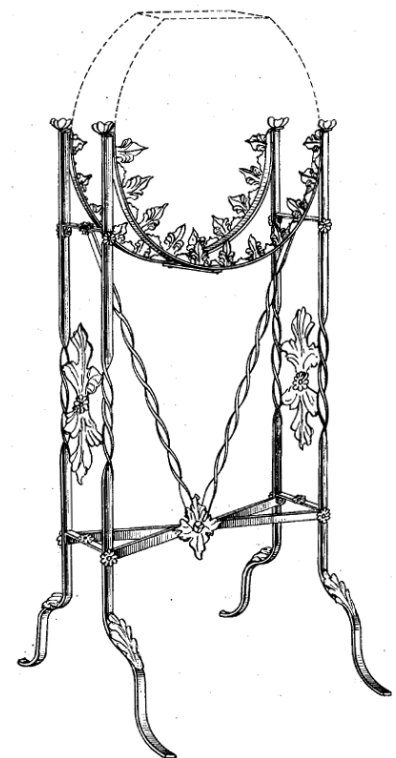

Figure 80: Bernard Tauman's stand for a circular globe, 1928.

[Figure 83, *Aquarium*, Number 1481435] William Rossberger of Wilmette, Illinois patented a rectangular aquarium design in 1924 with ornate feet, a feature that had been common during the previous decade. It was constructed of angle iron, painted or galvanized to protect it from rusting (galvanization, however, was a bad idea because of the toxicity of zinc to the fish should water came into contact with the metal). This was an all-welded design, an improvement over prior designs that utilized screws, rivets, or bolts, because the cement was set flat against the frame, minimizing leakage and rusting.

Figure 1 is a perspective view of the device, Figure 2 is a section along the line 2 - 2 of Figure 1 and Figure 3 is an enlarged section of a portion of the line 3 - 3 of Figure 1.

The invention made use of a metal frame consisting of the longitudinal members 1, the vertical members 2 and the transverse members 3. These frame members were preferably L-shaped in cross section similar to the angle irons used in building construction,

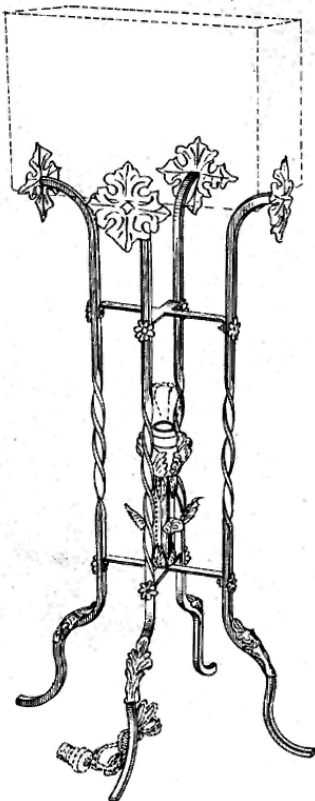

Figure 81:
Bernard Tauman's
stand for a
rectangular fish tank,
1928.

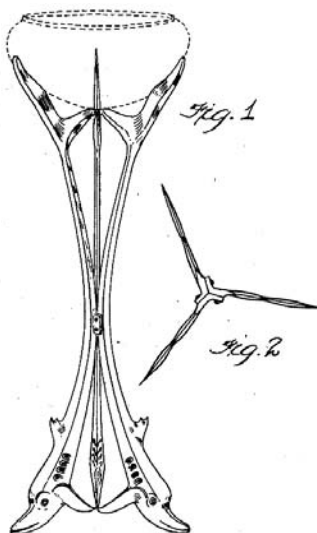

Figure 82:
Richard Rychtarik's
modern design, 1928.

being of course much smaller. The frame members were secured together at their ends in any suitable manner, but preferably by welding or soldering. In order to protect the frame from rust, one could galvanize it or give it a protective coating such as paint, enamel or other suitable covering. The frame was mounted on legs 4 and was preferably of the shape shown in the drawings. The bottom, sides and ends were of glass.

In constructing the aquarium a thin layer of cement or putty was first placed on the inwardly projecting edges of the bottom frame members. The bottom was then inserted from above. This was done by turning the bottom plate diagonally with respect to the frame, lowering it into the frame and then turning it into a horizontal position and lowering it so that it will rest on the in-turned portion of the bottom frame, members as shown in Figure 3. When the bottom plate 5 was in position, the side plates 6 were

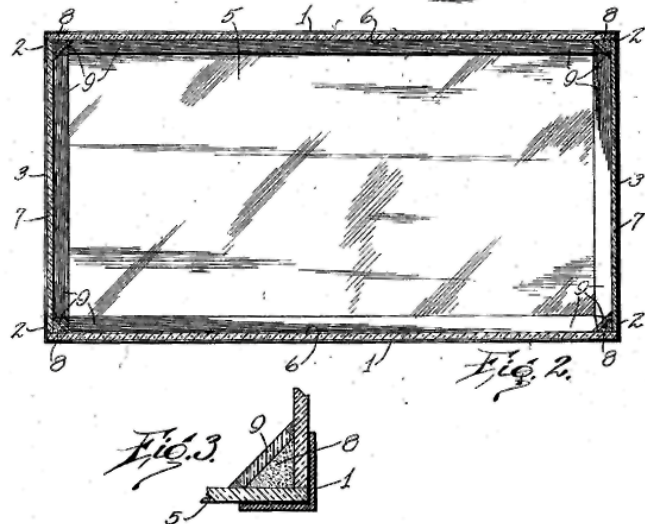
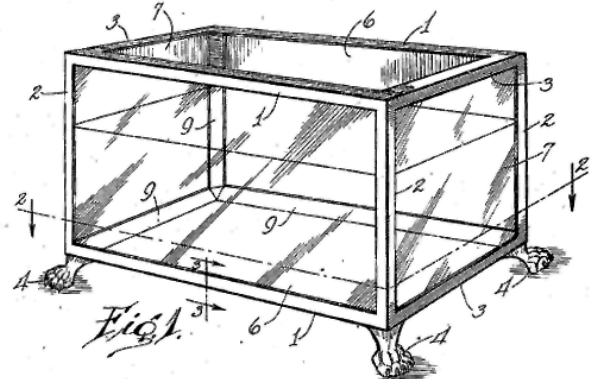

Figure 83: William Rossberger's footed,
rectangular design, 1924.

placed in position so as to rest on the bottom plate. The end plates 7 were then placed in position, thus forcing the side plates closely against the vertical frame members 2 so as to make a tight fit all around. When the glass plates were in position, waterproof putty or plastic cement 8 was filled in along the contacting edges of the sides, bottom, and end plates, and then glass strips 9 extending substantially the full length of the contiguous edges of the sides, ends and bottom plate were placed over the putty and forced toward the corners until the edges of the strips 9 engaged the contacting plates.

An aquarium constructed according to **this** invention had several distinct advantages over the ordinary aquarium. In certain aquariums, the joints were held together by means of screws or bolts, the ends of which projected into the aquarium. This tended to cause the rusting of the screws and to contaminate the water containing the fish. In this device, there were no such screws or bolts, and, of course, no such contamination. In certain aquariums where the joints were puttied or cemented, the putty tended to dry out, especially above the water line. It would then crack and the glass plates would become loose, permitting leakage. One of the main features of the invention was the fact that the putty or cement was covered by the plate 9 and did not dry out. Furthermore, the plates 9 tended to form bracing members at every joint where a slight movement would occasion the leakage of the aquarium. The aquarium thus constructed was braced at the bottom edges and at the corners so that the structure was rigid.

[Figure 84, *Illuminated Aquarium*, Number 1297254] This decade ushered in a new type of aquarium design – a combination of a decorative lamp and an aquarium in which one of the aims was to illuminate the fish. The first to arrive on the scene was created by Natsuo Sato of San Francisco in 1919. The cleverness of the design should not be overlooked. Not only was it aesthetically pleasing, but it was designed so that the shade portion, base, the electrical wires, and the conduit that ran through the center of the aquarium could be disconnected and removed, leaving just the aquarium. Sato assumed that if the aquarium was planted, the plant growth at the bottom would hinder the fish in search of food so

he included a glass food platform hung from the top of the aquarium. Access to the aquarium was provided by the cover at the top that could be raised around the electrical conduit when required.

Figure 1 is a broken side view, showing a bowl, lamp and lamp shade, constructed in accordance with the invention, Fig. 2 is a detail vertical sectional view, Fig. 3 is a similar view of a modification, certain portions being shown in side elevation and Figs. 4 and 5 were perspective views of different forms of stands for supporting food for the fishes contained in the bowl.

In order to present a pleasing appearance, it was desirable that the bowl should have therein a bed 21 of sand, gravel or the like, in which aquatic plants 22 could grow. However, some aquatic plants made it difficult for the fish to obtain access to food that was

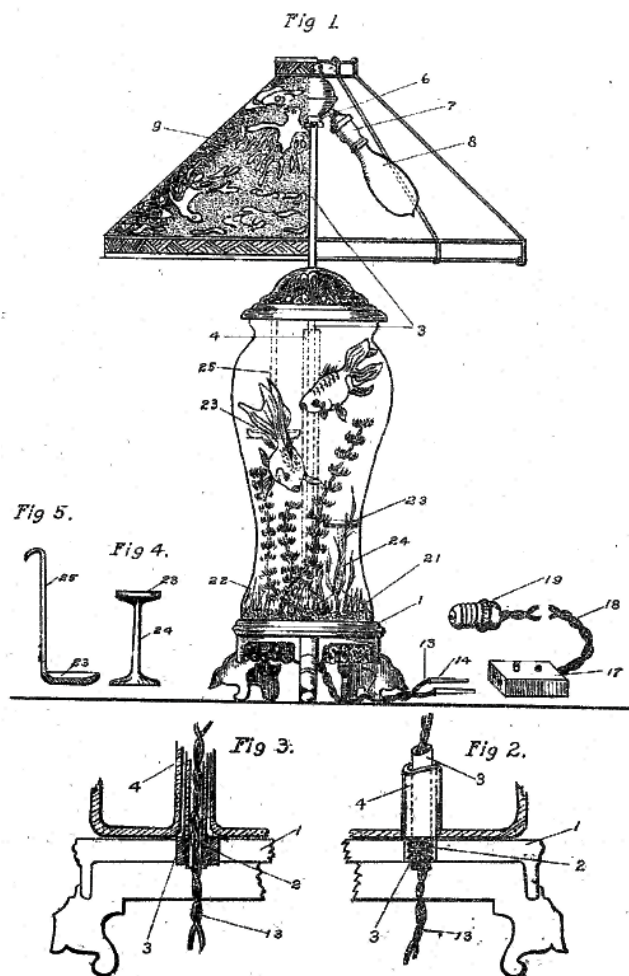

Figure 84: Natsuo Sato's lamp Aquarium, 1919.

allowed to sink to the bottom of the bowl. To overcome this difficulty, provision was made for a glass plate or holder **23** having a stem **24**, as shown in Fig. 4, or having a hanger **25** as shown in Fig. 5, upon which the food could be placed at a sufficient height above the aquatic plants in the bowl to enable the fish to have easy access to. The above described construction allowed the lamp shade, lamp and the pipe to be easily detached when required.

[Figure 85, *Illuminated Aquarium, Number 1333454*] Sato followed up this design in 1920 with

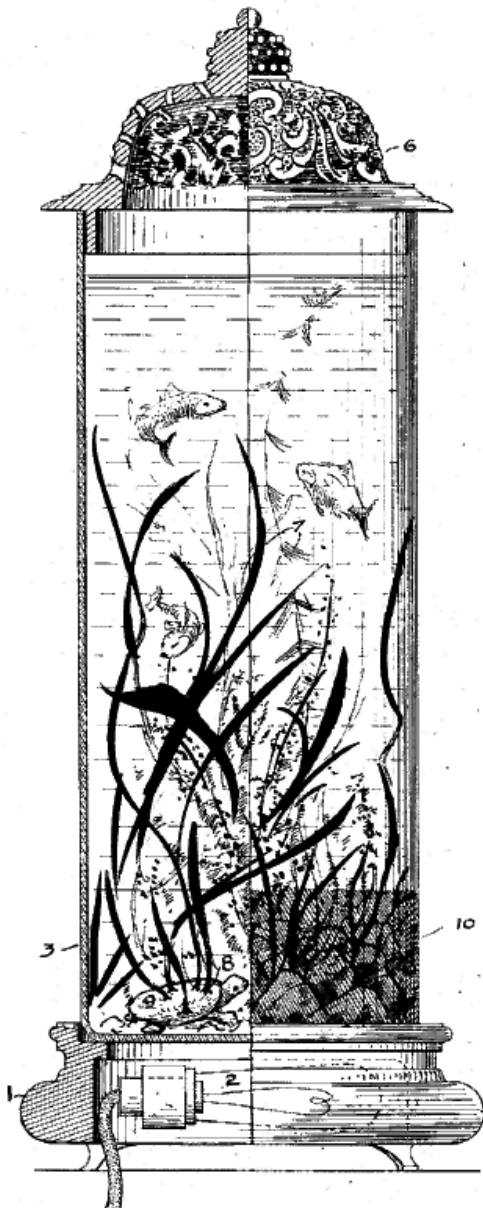

Figure 85: Natsuo Sato's second lamp Aquarium, 1920.

one that comprised a cylindrical design that did not have a lamp shade, the illumination being provided by one or more lamps in the base (*Illuminated Aquarium, Number 1333454*). Since the bottom of the cylinder was clear and because Sato specified that the bottom of the cylinder was not to be covered by sand or gravel, the light shone up onto the fish and the plants.

In the accompanying drawing the figure is a broken side view of the aquarium. **1** indicates a suitable hollow base, preferably circular in form, in which were contained one or more electric lamps **2**, one only being shown. The base is open at the top and upon the top was the main body **3** of the aquarium in the form of a glass cylinder having a glass closed bottom formed in one piece with the glass cylinder. Closing the top of the cylinder was an ornamental top **6**. In the cylinder were contained a number of aquatic plants or grasses **7**, the bottoms of which were tied or otherwise secured as shown at **8**, to weighted objects **9** that could be in the form of small imitation turtles, rocks or other objects that served as anchors for the plants to the bottom of the cylinder.

Sato did not, however, cover the bottom of the cylinder with sand or gravel, but allowed the light of the lamp to shine through. The rays of the lamp impinging upon the grasses or plants and upon the goldfish or other fish swimming in the aquarium produced a very pleasing effect. In order that the direct rays of the lamp would not impinge upon the eye of the observer, Sato preferred to paint the exterior surface of the lower portion of the cylinder, as shown at **10**, to represent rocks and aquatic vegetation clinging thereto. These painted representations, illuminated by the rays of the electric lamp traversing the water, added greatly to the pleasing effect of the aquarium.

[Figure 86, *Lamp, Number 14497726*] The next lamp aquarium on the scene was patented by Frederick L. Miller of Newark, New Jersey (*Lamp, Number 1449772*) in 1923. This design also incorporated lights in the base so that light could be directed upwards into the glass aquarium. The top of the aquarium was open but even so, access must have been awkward.

Figure 1 was an elevation of a table lamp showing one embodiment of the principles of the invention, Figure 2 was a transverse vertical section taken on line 2 - 2 in Figure 1 looking in the direction of the arrow x, Figure 3 was a horizontal section of the lamp taken on line 3 - 3 in Figure 2 and Figure 4 was a diagrammatic view of the electrical circuits and lamps with an arrangement of switches for turning on the lights in the upper structure of the lamp, or for turning on the lights in the lower structure of the lamp.

In Figures 1 and 2, the transparent container, adapted to be illuminated from the lights 21, the bulbs could be of any desired color and could be provided with a quantity of water for use as an aquarium as shown, but of course the interior of the container could have placed therein any other suitable display device, such as artificial flowers, to greatly enhance the pedestal and the general beauty of the main lamp.

[Figure 87, *Design for a Fish Bowl Support, Number D78595*] In 1928 a sort of minimalist aquarium lamp patent was awarded to Bernard Tauman of Chicago. Figure 1 is a front elevation of the aquarium and Figure 2 is a side elevation. Only a very small shade surrounded the lamp, so this rather easily tipped over design did afford easy access to the fish for cleaning and feeding. The problem with all of these lamp aquarium ideas is clearly the close proximity of electrical wires to water, exacerbated by the fact that at

the time neither electrical wires nor their contacts were particularly safe.

[Figure 88, *Aquarium, Number 1643527*] The last lamp aquarium of the decade had a really strange look to it. In 1927, Herbert A. Stone of Chicago was awarded a patent for a design that attempted to conceal the frame and provide a rustic appearance. Stone covered the frame (and even the lamp housing) with a “cementitious (sic) substance” to achieve the effect. Stone does not state how the frame was put together, but no rivets or bolts were shown in the diagram. To simply conceal an aquarium frame that is usually ignored anyway, this was clearly overkill.

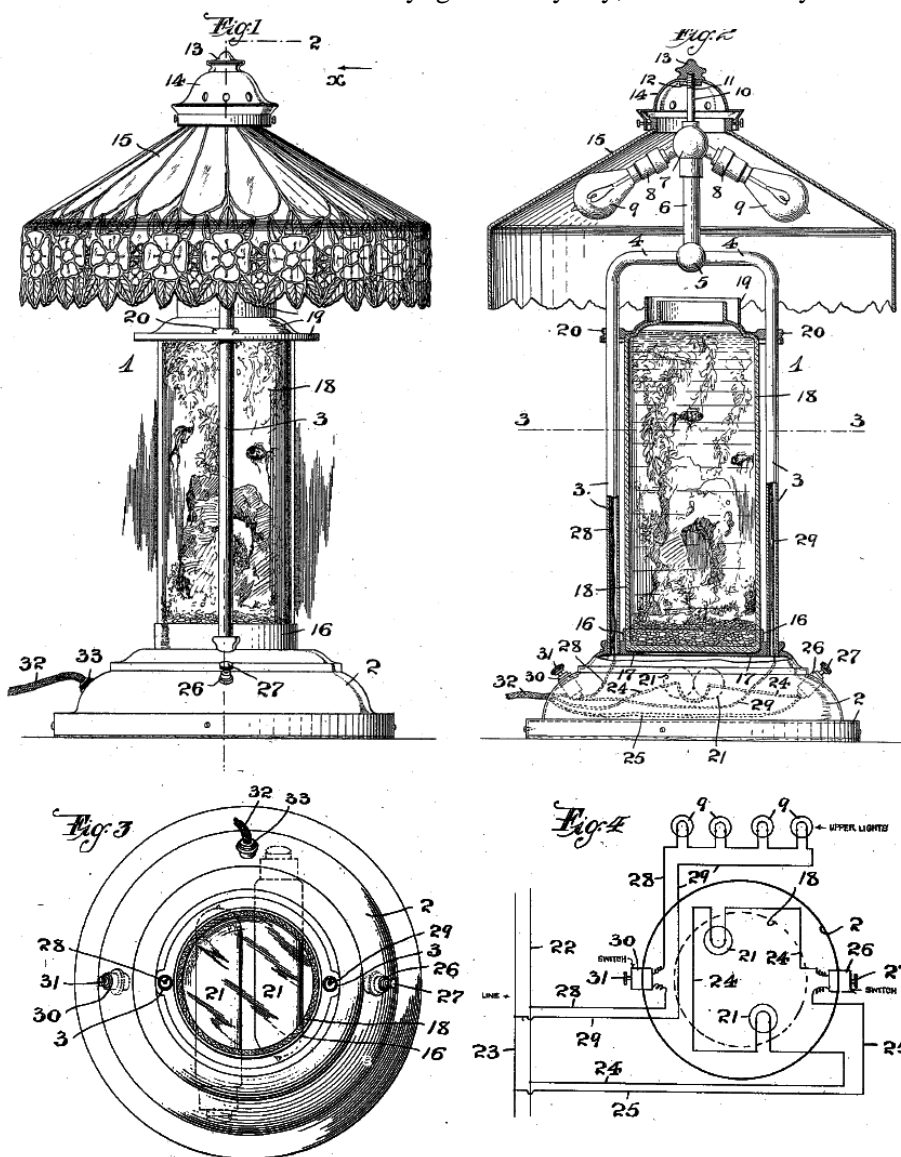

Figure 86: Frederick L. Miller's lamp aquarium, 1923.

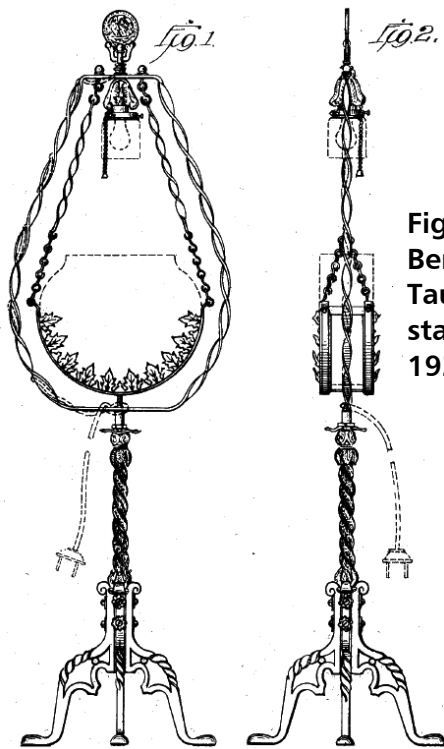

Figure 87:
Bernard
Tauman's lamp
stand aquarium,
1928.

Figure 1 is a plan view of the preferred form of construction embodying the invention, Fig. 2 is a side elevation, Fig. 3 is a vertical cross section, Fig. 4 is a partial vertical longitudinal section, taken on line 4 - 4 of Fig. 3 and Fig. 5 is a partial horizontal section taken on line 5 - 5 of Fig. 3.

The invention was composed of a container with transparent wall members or plates including end members 7, side members 8 and a bottom member 9, all supported on a base 10. Around these transparent wall members were mounted a frame containing members 11 and 11' of metal or other durable material placed at the vertical joining edges of the wall members, and similar members 12 and 12' placed at the top edges. Metallic members were connected in a suitable manner to produce a durable structure, while sealing means 13 were placed on the inside of the joining edges of the wall members to produce a tight container for retaining the water.

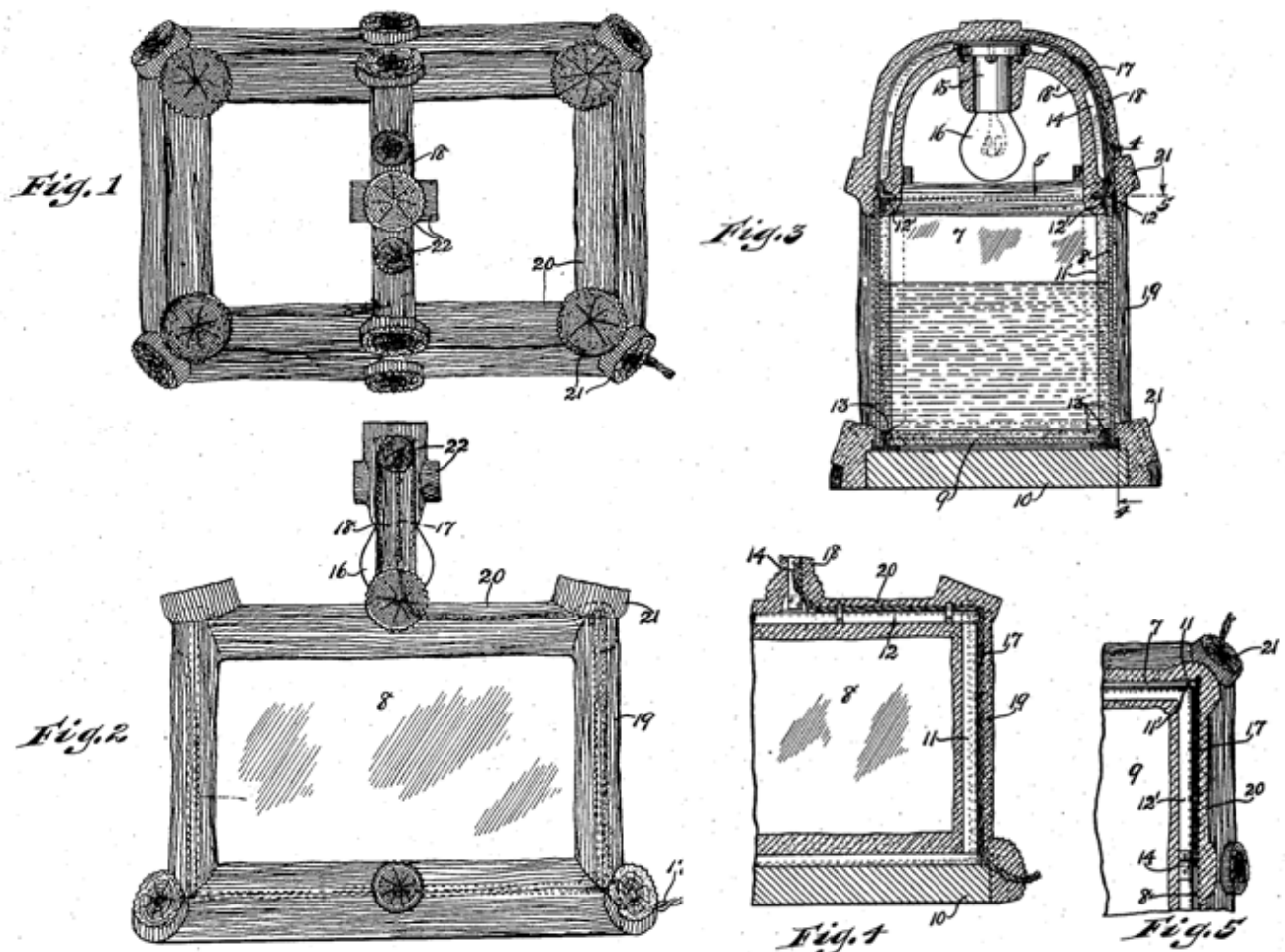

Figure 88: Herbert A. Stone's rustic aquarium, 1927.

Provided over the container and especially over the frame was an arch. It included a metallic arch member **14** mounted with its lower ends on the metallic members **12'** and was arranged at its top to provide a lighting fixture via a socket member **15** for supporting an electric light bulb or lamp **16** so as to provide an overhead lighting fixture for illuminating the aquarium from above. An electric conductor **17** extended from the socket along the arch member **14** and along the frame members **12** and **11** to the base **10**.

The conductor **17** was entirely housed and concealed for its entire distance from the lighting fixture down to where it extended from the base or bottom of the structure. Covering was placed over the arch member **14** as shown at **18** and **18'**, and over the metallic members **11** and **11'** as shown at **19**, and over members **12** and **12'** as shown at **20**, thereby covering and concealing the conductor and at the same time completing the arch and frame or structure of the aquarium. For this covering a cementitious substance was used. This was applied in the plastic condition and molded or formed on the frame members over the conductor to cover them. The inventor arranged the construction of the arch and frame so that a space was provided in the structure for housing and concealing the conductor therein, and he also arranged the covering so as to form a roughened exterior, preferably having knots or stub branches **21** on the frame part and similar knots or stub branches **22** on the arch as shown in the Figures. Thus this gave the structure a rustic appearance and provided a rustic aquarium with an overhead lighting fixture and a conductor extending therefrom being entirely concealed in the structure of the arch and container.

[Figure 89, *Illuminated Aquarium*, Number 1634305] The 1927 aquarium design of John A. Schrimp of Los Angeles was particularly interesting in that it had a removable section that had miniature hills, valleys, and mountains constructed of a ceramic that could be removed from the aquarium

for cleaning. Since this structure had its own floor, the tank was double-bottomed. Small holes were drilled into this structure so that sediment could pass through to the space between the double-bottom. The dirty water then could be drained via a valve located underneath the tank. The frame of the tank was made of metal and connected to the metal bottom. This is an octagonal aquarium, and at the top of each of its eight corners was a light bulb; a ninth light bulb was located in the center of the tank within a glass container. When the switch was thrown, Schrimp's aquarium must have looked like a Christmas tree! Like the lamp aquariums, however, there was always a danger of electric shock should the water leak into the large lamp container or the conduits containing the wires that led to the eight topmost lights.

Figure 1 is a side elevational view of an aquarium embodying the principles of the invention, Fig. 2 is a horizontal section taken on the line 2 - 2 of Fig. 1

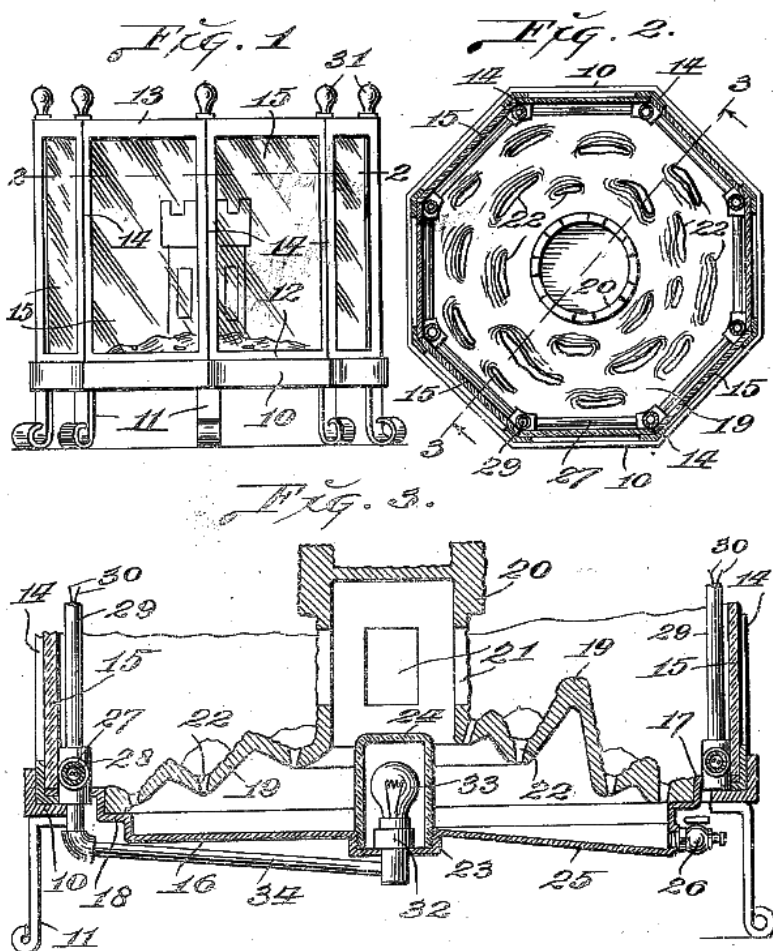

Figure 89: John A. Schrimp's octagonal design, 1927.



and Fig. 3 is an enlarged cross section taken on line 3 - 3 of Fig. 2.

Formed through the removable bottom and arranged in the lower portions of the depressions or valleys therein were slots or apertures that permitted all sediment and the like that could gravitate to the bottom of the aquarium to pass into the space between the removable bottom and the bottom member 16. Formed at the center of bottom member was a depression 23 that was internally threaded and removably seated therein was the externally threaded lower end of an inverted cup-shaped member 24 of glass. Formed in the bottom member and leading from the depression outwardly to the edge of the bottom member was a trough-like depression 25 that served as a drain when the water in the aquarium was being drawn off, and arranged in the wall of member 16 at the outer end of this depression was a valve 26.

When current was supplied to the conductors, the lamps 31 and 33 would be lighted, thereby adding materially to the appearance of the aquarium, particularly at night. The interior of the aquarium would be

illuminated to a certain extent as a result of light rays from lamp 33 passing outwardly through the openings 22 in the removable bottom member 19 and through the window openings 21 in the castle representing member 20. An aquarium constructed in accordance with the invention presented a novel, interesting and pleasing appearance that was especially adapted for decorative purposes. All sediment and small particles of food that would otherwise accumulate on bottom member 19 would readily pass through the apertures 22 into the space between the members 16 and 19 where they were hidden from view and from whence they were removed through channel 25 and valve 26 when the aquarium was drained. The earthenware bottom member 19 being shaped to represent hills, valleys and a tower or castle, added materially to the appearance of the aquarium, and as this bottom member was formed in a single piece, it could be readily removed and cleaned.



Figure 1 was an elevation of a table lamp showing one embodiment of the principles of the invention, Figure 2 was a transverse vertical section taken on line 2 - 2 in Figure 1 looking in the direction of the arrow x, Figure 3 was a horizontal section of the lamp taken on line 3 - 3 in Figure 2 and Figure 4 was a diagrammatic view of the electrical circuits and lamps with an arrangement of switches for turning on the lights in the upper structure of the lamp, or for turning on the lights in the lower structure of the lamp.

In Figures 1 and 2, the transparent container, adapted to be illuminated from the lights 21, the bulbs could be of any desired color and could be provided with a quantity of water for use as an aquarium as shown, but of course the interior of the container could have placed therein any other suitable display device, such as artificial flowers, to greatly enhance the pedestal and the general beauty of the main lamp.

[Figure 87, *Design for a Fish Bowl Support, Number D78595*] In 1928 a sort of minimalist aquarium lamp patent was awarded to Bernard Tauman of Chicago. Figure 1 is a front elevation of the aquarium and Figure 2 is a side elevation. Only a very small shade surrounded the lamp, so this rather easily tipped over design did afford easy access to the fish for cleaning and feeding. The problem with all of these lamp aquarium ideas is clearly the close proximity of electrical wires to water, exacerbated by the fact that at

the time neither electrical wires nor their contacts were particularly safe.

[Figure 88, *Aquarium, Number 1643527*] The last lamp aquarium of the decade had a really strange look to it. In 1927, Herbert A. Stone of Chicago was awarded a patent for a design that attempted to conceal the frame and provide a rustic appearance. Stone covered the frame (and even the lamp housing) with a "cementitious (sic) substance" to achieve the effect. Stone does not state how the frame was put together, but no rivets or bolts were shown in the diagram. To simply conceal an aquarium frame that is usually ignored anyway, this was clearly overkill.

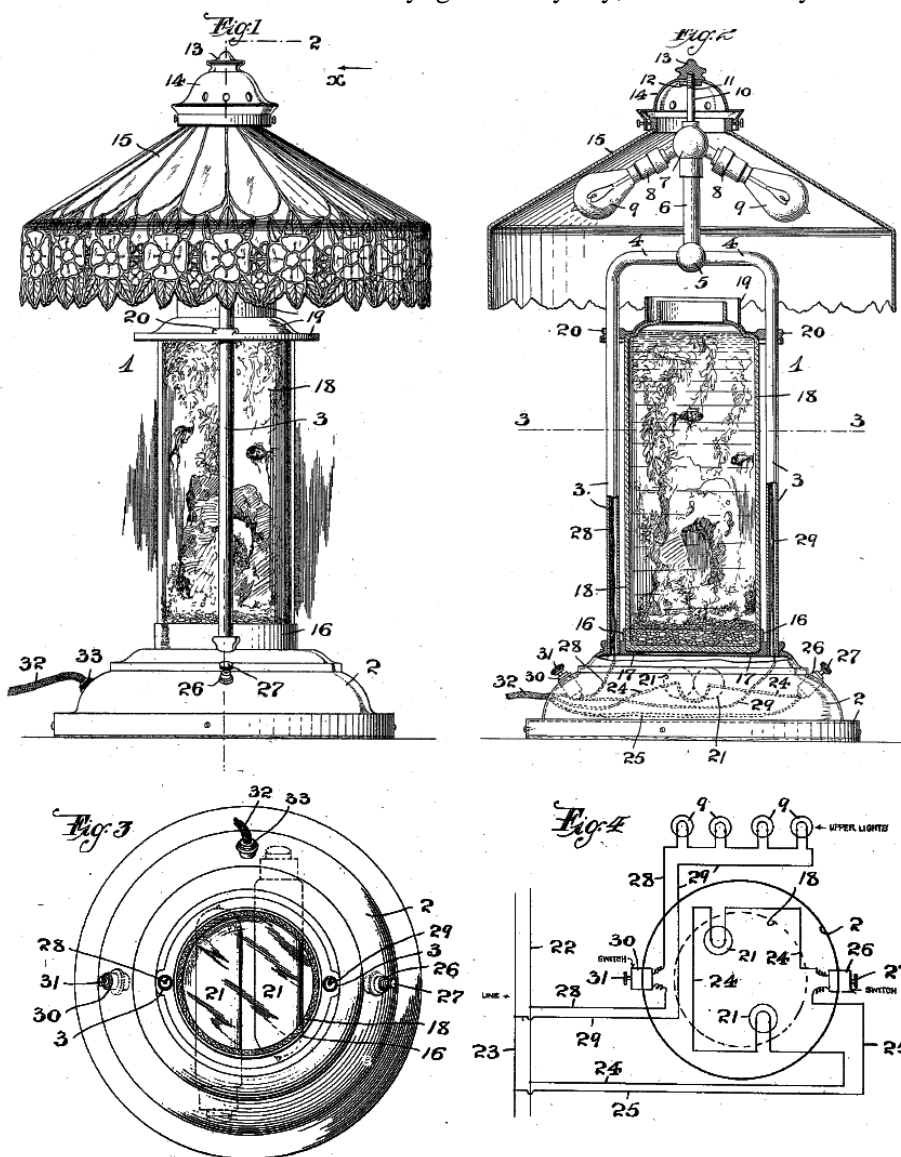

Figure 86: Frederick L. Miller's lamp aquarium, 1923.

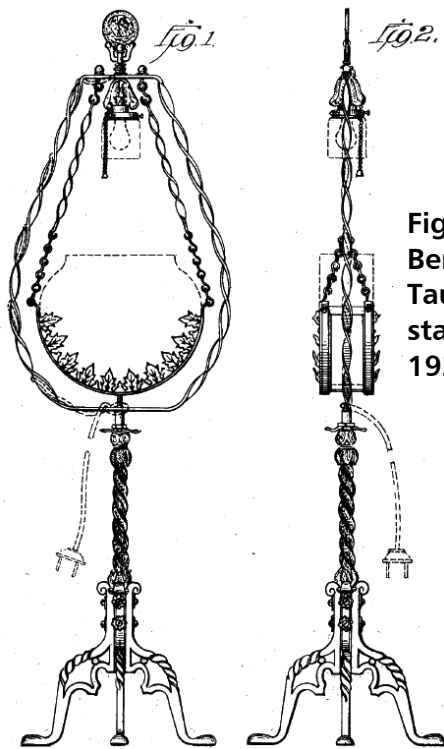

Figure 87:
Bernard
Tauman's lamp
stand aquarium,
1928.

Figure 1 is a plan view of the preferred form of construction embodying the invention, Fig. 2 is a side elevation, Fig. 3 is a vertical cross section, Fig. 4 is a partial vertical longitudinal section, taken on line 4 - 4 of Fig. 3 and Fig. 5 is a partial horizontal section taken on line 5 - 5 of Fig. 3.

The invention was composed of a container with transparent wall members or plates including end members 7, side members 8 and a bottom member 9, all supported on a base 10. Around these transparent wall members were mounted a frame containing members 11 and 11' of metal or other durable material placed at the vertical joining edges of the wall members, and similar members 12 and 12' placed at the top edges. Metallic members were connected in a suitable manner to produce a durable structure, while sealing means 13 were placed on the inside of the joining edges of the wall members to produce a tight container for retaining the water.

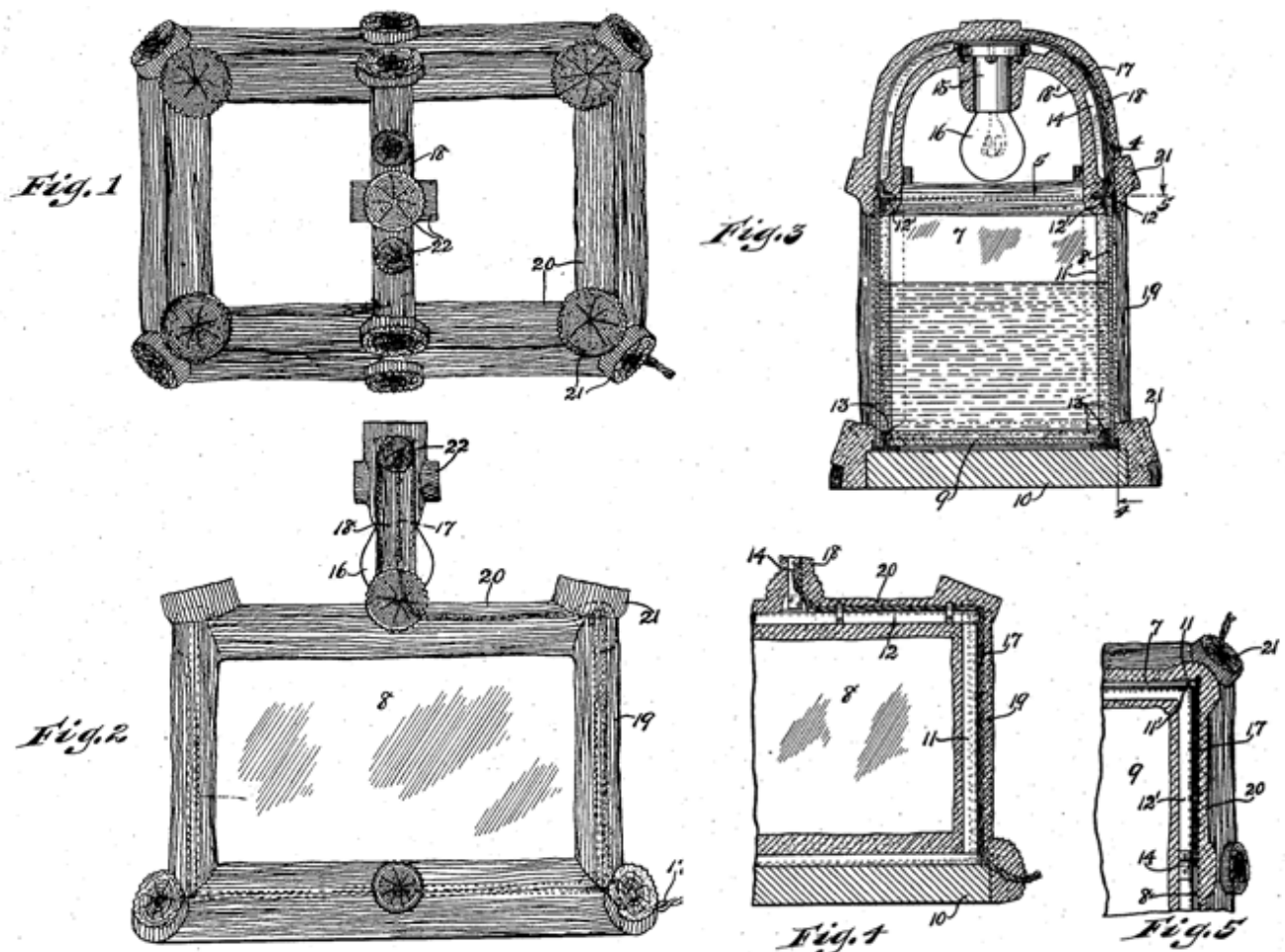

Figure 88: Herbert A. Stone's rustic aquarium, 1927.

Provided over the container and especially over the frame was an arch. It included a metallic arch member **14** mounted with its lower ends on the metallic members **12'** and was arranged at its top to provide a lighting fixture via a socket member **15** for supporting an electric light bulb or lamp **16** so as to provide an overhead lighting fixture for illuminating the aquarium from above. An electric conductor **17** extended from the socket along the arch member **14** and along the frame members **12** and **11** to the base **10**.

The conductor **17** was entirely housed and concealed for its entire distance from the lighting fixture down to where it extended from the base or bottom of the structure. Covering was placed over the arch member **14** as shown at **18** and **18'**, and over the metallic members **11** and **11'** as shown at **19**, and over members **12** and **12'** as shown at **20**, thereby covering and concealing the conductor and at the same time completing the arch and frame or structure of the aquarium. For this covering a cementitious substance was used. This was applied in the plastic condition and molded or formed on the frame members over the conductor to cover them. The inventor arranged the construction of the arch and frame so that a space was provided in the structure for housing and concealing the conductor therein, and he also arranged the covering so as to form a roughened exterior, preferably having knots or stub branches **21** on the frame part and similar knots or stub branches **22** on the arch as shown in the Figures. Thus this gave the structure a rustic appearance and provided a rustic aquarium with an overhead lighting fixture and a conductor extending therefrom being entirely concealed in the structure of the arch and container.

[Figure 89, *Illuminated Aquarium*, Number 1634305] The 1927 aquarium design of John A. Schrimp of Los Angeles was particularly interesting in that it had a removable section that had miniature hills, valleys, and mountains constructed of a ceramic that could be removed from the aquarium

for cleaning. Since this structure had its own floor, the tank was double-bottomed. Small holes were drilled into this structure so that sediment could pass through to the space between the double-bottom. The dirty water then could be drained via a valve located underneath the tank. The frame of the tank was made of metal and connected to the metal bottom. This is an octagonal aquarium, and at the top of each of its eight corners was a light bulb; a ninth light bulb was located in the center of the tank within a glass container. When the switch was thrown, Schrimp's aquarium must have looked like a Christmas tree! Like the lamp aquariums, however, there was always a danger of electric shock should the water leak into the large lamp container or the conduits containing the wires that led to the eight topmost lights.

Figure 1 is a side elevational view of an aquarium embodying the principles of the invention, Fig. 2 is a horizontal section taken on the line 2 - 2 of Fig. 1

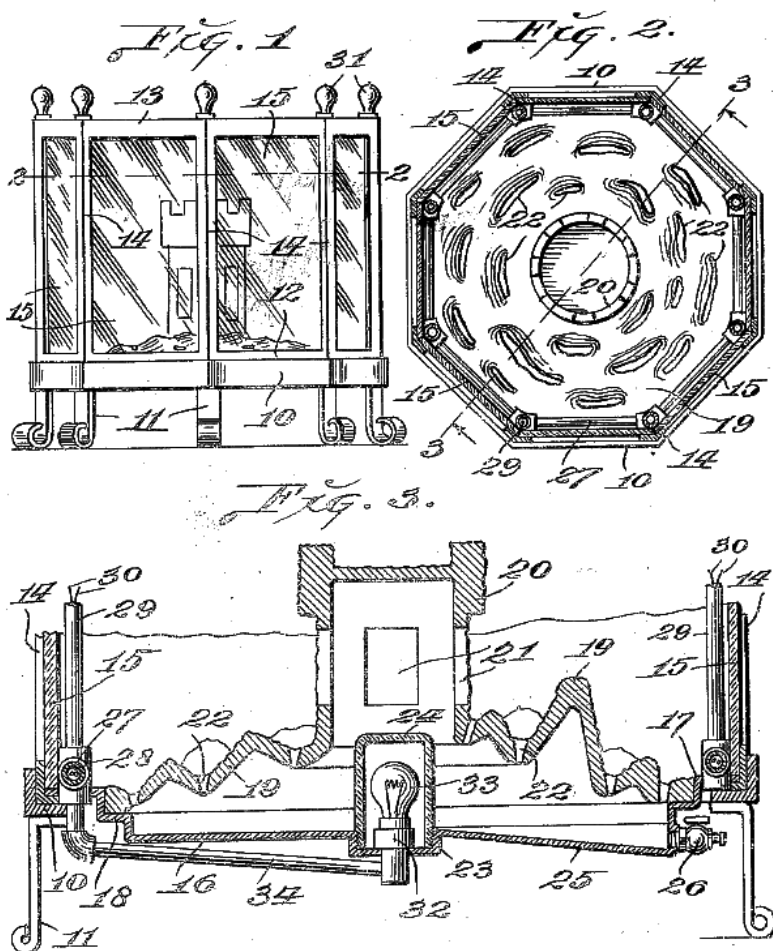

Figure 89: John A. Schrimp's octagonal design, 1927.



and Fig. 3 is an enlarged cross section taken on line 3 - 3 of Fig. 2.

Formed through the removable bottom and arranged in the lower portions of the depressions or valleys therein were slots or apertures that permitted all sediment and the like that could gravitate to the bottom of the aquarium to pass into the space between the removable bottom and the bottom member 16. Formed at the center of bottom member was a depression 23 that was internally threaded and removably seated therein was the externally threaded lower end of an inverted cup-shaped member 24 of glass. Formed in the bottom member and leading from the depression outwardly to the edge of the bottom member was a trough-like depression 25 that served as a drain when the water in the aquarium was being drawn off, and arranged in the wall of member 16 at the outer end of this depression was a valve 26.

When current was supplied to the conductors, the lamps 31 and 33 would be lighted, thereby adding materially to the appearance of the aquarium, particularly at night. The interior of the aquarium would be

illuminated to a certain extent as a result of light rays from lamp 33 passing outwardly through the openings 22 in the removable bottom member 19 and through the window openings 21 in the castle representing member 20. An aquarium constructed in accordance with the invention presented a novel, interesting and pleasing appearance that was especially adapted for decorative purposes. All sediment and small particles of food that would otherwise accumulate on bottom member 19 would readily pass through the apertures 22 into the space between the members 16 and 19 where they were hidden from view and from whence they were removed through channel 25 and valve 26 when the aquarium was drained. The earthenware bottom member 19 being shaped to represent hills, valleys and a tower or castle, added materially to the appearance of the aquarium, and as this bottom member was formed in a single piece, it could be readily removed and cleaned.





THE GREAT DEPRESSION: THE DECADE OF 1929-1938

[Figure 90, *Aquarium*, Number 1852597] In 1932 Fay E. Taylor and James M. Conway of St. Louis, Missouri obtained a patent for the construction of an aquarium from a single sheet of metal. Rectangles were cut out as shown in the diagram and the resulting sheet was folded to produce the finished frame, the last seam being welded together. Adding glass sides and a glass bottom completed the aquarium. Tabs were left at the top of the frame and folded over, thus insuring that the aquarist could not cut his hands on any sharp metal edges. This was a well-thought out idea but there was a lot of waste in the cut out rectangles.

Fig. 1 shows the sides, ends and legs of the invention blanked from a single sheet of metal, Fig. 2 is a side elevation of a completed structure, Fig. 3 is an end elevation of a completed structure and Fig. 4 is a cross-section along the line 4 - 4 in Fig. 2.

The method of construction of the invention consisted of the use of a strip of sheet metal blanked out as shown in Fig. 1. The upper marginal edge of the blank was provided with three angle slots, designated as 1, 2 and 3. The lower marginal edge of the blank was provided with four depending projections, designated as 4, 5, 6 and 7. Cutouts for the ends are designated as 8 and 9, and for the sides as 10 and 11.

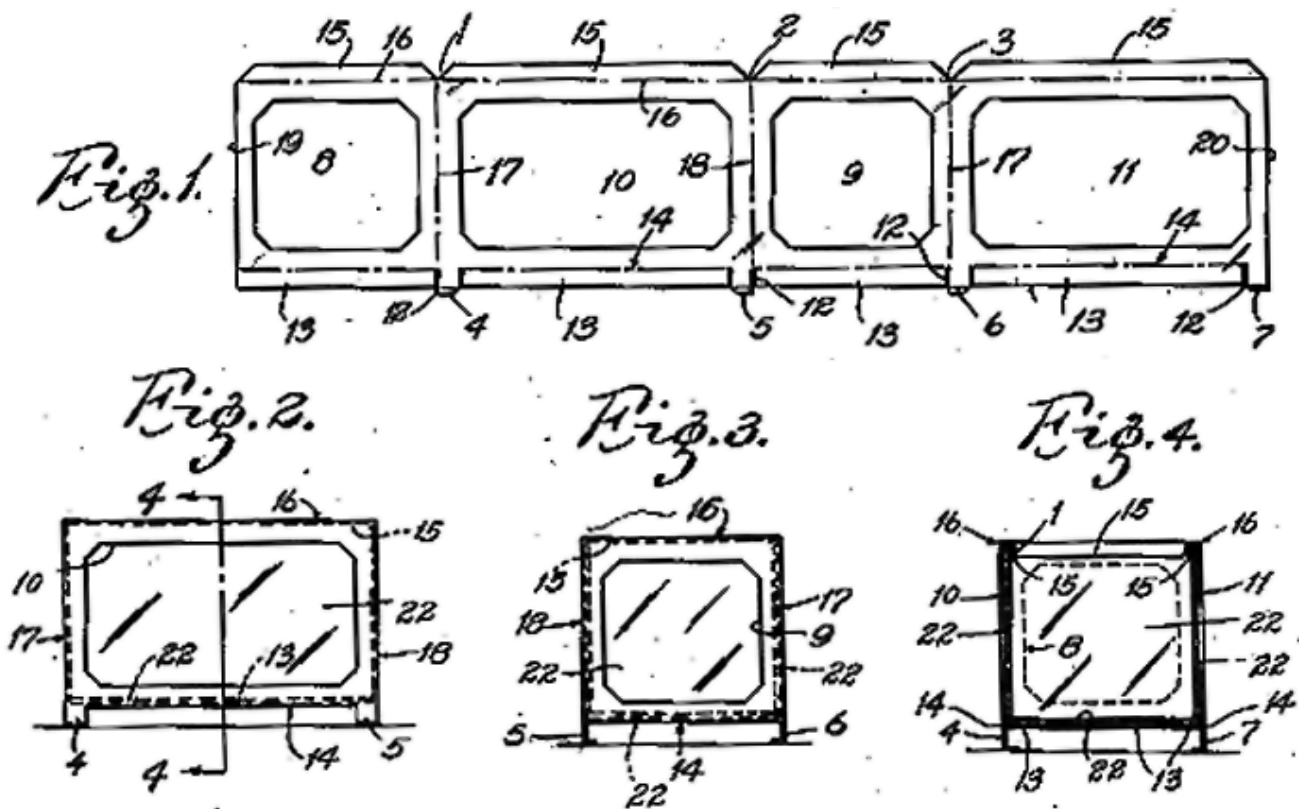

Figure 90: Fay E. Taylor and James M. Conway's aquarium from a single metal sheet, 1932.

The metal was severed from the legs at 12 so that the lower portion 13 of the strip was turned inwardly at a right angle along the line 14, forming a substantial support for the bottom and at the same time strengthening the sides. Likewise, along the upper marginal edge 15 of the strip it was turned inwardly at a right angle along the line 16. Likewise the sides 10 and ends 8 were turned at right angles and also at 19 so that the portions 8 and 9 lay parallel with each other. The portions 10 and 11 laid parallel with each other and at right angles to the portions 8 and 9, forming a complete quadrilateral.

When the metal was thus formed into shape, the edges 19 and 20 were welded together. Glass sides and bottom were formed by the introduction of panes of glass cut to snugly fit the iron framework and were embedded in a suitable cement or putty having the characteristic of hardening under water.

[Figure 91, *Indoor Garden Box and Aquarium, Number 2081023*] Another aquarium construction design was patented by Lewis Teach of Brooklyn in 1937 and used L-shaped exterior and internal flanges, bolted to the bottom of the aquarium. No top frame was used in this design. Figure 1 is a plan view of the box, Figure 2 is a front elevational view of one end of the box, Figure 3 is a cross-sectional view taken on the line 3 - 3 of Figure 1 and Figure 4 is a cross-sectional view taken on the line 4 - 4 of Figure 1.

At each corner a removable leg 21 of Catalin (a brand name for a thermosetting polymer developed and trademarked in 1927 or other desirable material was mounted. The leg 21 had a vertical bore 22 passing through and was secured to the base by means of the bolt 19 passing down through the bore. At the bottom the bore was widened to provide a mouth 23 into which the threaded end of the bolt 19 projected. A nut 24 was screwed on to the bolt 19 and the tightening of this nut drew the post 18 down to sit securely on the boss 17. At the same time the post lug 20 was forced down against the corners of the glass walls 15 to lock the wall panels together. The bolt

end and the nut 24 were covered by means of a cap 25 of felt or similar material that was secured about the enlarged bottom mouth of the bore 22 and also covered the bottom of the leg 21.

The box could be used as an indoor garden box with or without a glass cover (not shown). The latter was used when very small plants were raised in the box and suitable ventilation could be provided in the cover. This cover served to trap and retain moisture within the soil contained in the box as well as serving as a heat insulator to keep the growing plants warm. The box could be used as an aquarium without a cover and, if desired, additional waterproofing provision (not shown) could be used.

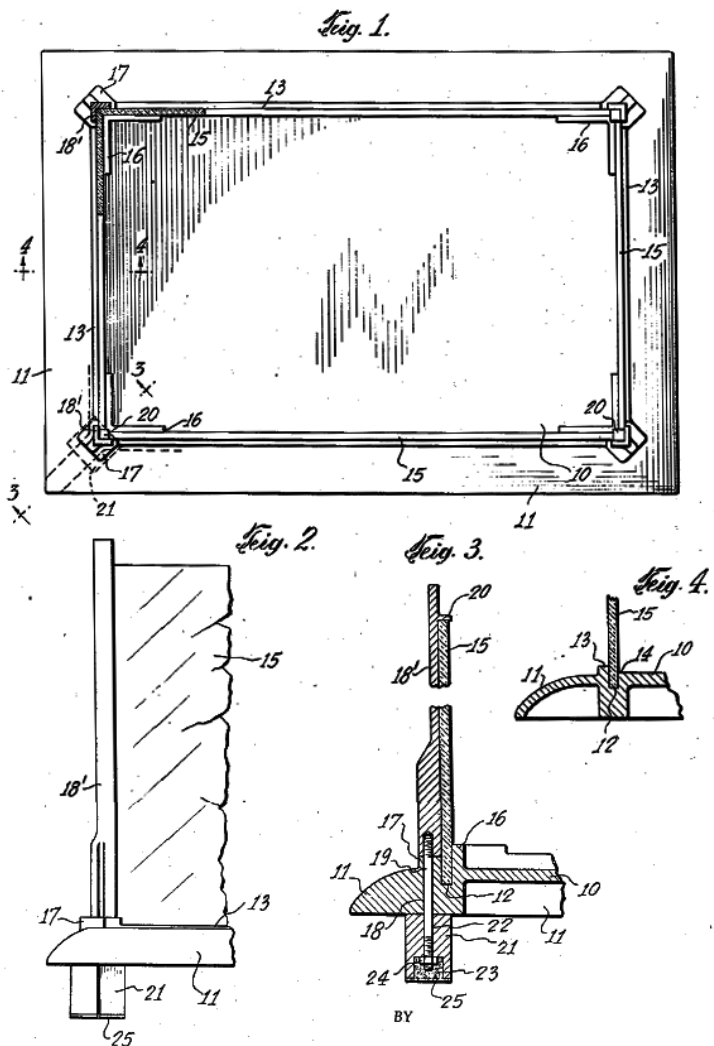

Figure 91: Lewis Teach's aquarium construction patent, 1937.

[Figure 92, *Aquarium, Number 1986018*] Alfred C. Schoepfer of Birmingham, Michigan patented a new type of aquarium construction in 1933 in which the corner posts contained V-grooves into which the glass was inserted. Aquarium cement was placed into the grooves before insertion, and the glass was beveled so that a very tight fit was obtained. When the caps were screwed into the top of the posts, they pressed the glass into the grooves in the base plate, again ensuring a tight seal. The corner posts extended into the base plate and, having threaded lugs on

that end, were secured with threaded caps. If the base were made of glass, the entire aquarium save the posts was then made of glass, although Schoepfer suggested marble could be used. There was, however, no top frame, but as this design was shallow in height it was not really needed. Nonetheless, the work involved in beveling glass (and marble, if it was used for the base) would have made it very costly to manufacture.

Fig. 1 is a perspective view of an aquarium embodying the invention, Fig. 2 is a section taken on line 2 - 2 of Fig. 1, Fig. 3 is a section taken on line 3 - 3 of Fig. 1 and Fig. 4 is a section taken on line 4 - 4 of Fig. 2.

With the aquarium constructed as shown, it was not necessary to provide a frame as the corner posts extended through the base plate and the cap nuts 9 on the lower ends of the corner posts 5 provided supports for the base plate. With all of the parts except the corner posts made of glass a very transparent aquarium was provided due to the absence of extra framework. This type of aquarium lent itself admirably to illumination from the exterior. While glass could be for the base plate, it could also be made of marble, slate or composition material. Also the channels 15 in the corner posts did not necessarily need to be V-shaped as a straight sided channel would operate satisfactorily at this point. The device could be easily and quickly assembled, would not readily leak when so assembled and was of a pleasing appearance

[Figure 93, *Process of Manufacturing Glass Containers for Liquid, Number 2016439*] H. Hogan of Oklahoma City, Oklahoma patented an elaborate aquarium design in 1935 that was meant to conceal the frame so that a rough non-machined framework

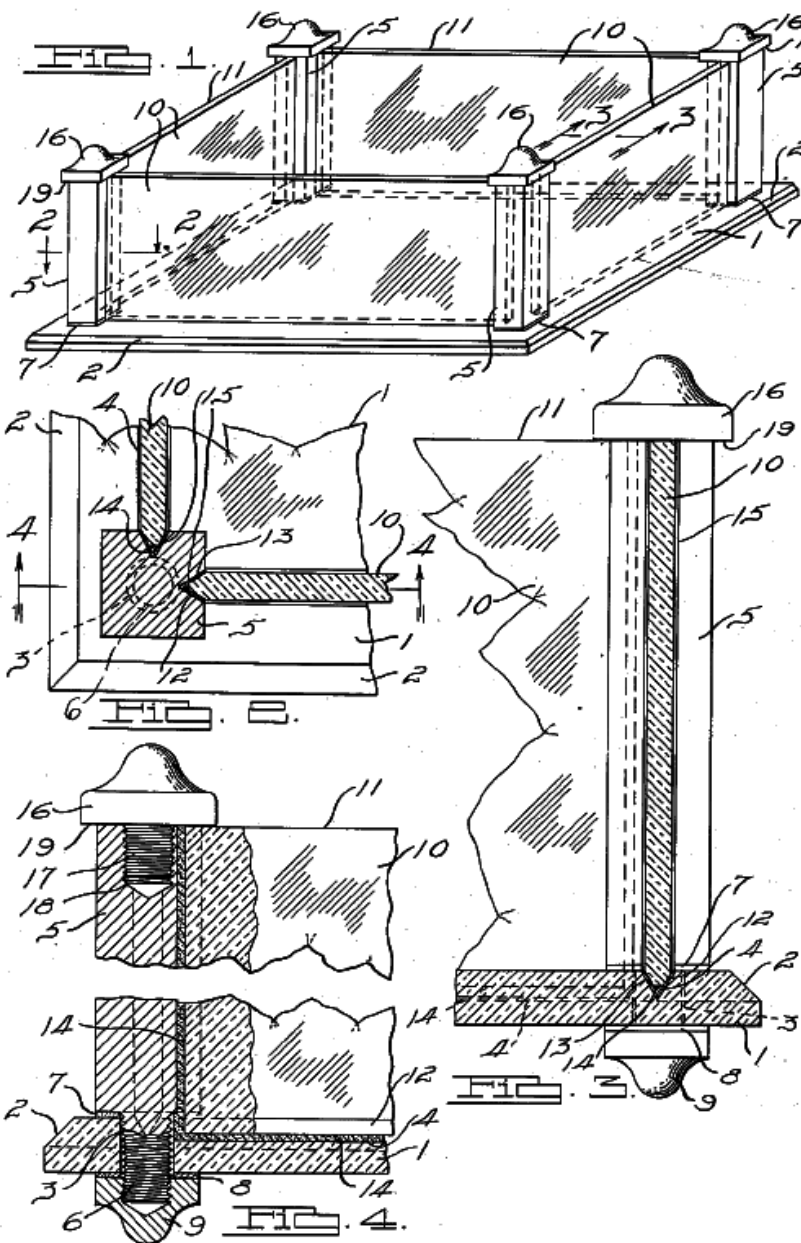

Figure 92: Alfred C. Schoepfer's V-groove, glass construction, 1933.

could be used to keep costs low. To do this, he constructed a frame using flexible strips (17 in Figure 3) on each side to form a mold (Fig. 4). Then, using glass or metal plates for the outside of the mold, he poured in a liquid material capable of becoming solidified after it had set. After the forms were removed the completed aquarium looked like that shown in Fig. 5. With regard to the liquid material that solidified, Hogan referred to a patent granted to Richard C. Hollis of Shreveport, Louisiana in 1928 for an artificial stone. I won't go into the details, but it consisted of a mixture of superfine Portland cement, magnesite, alum and silica. To this was added a concoction of water, flake magnesium chloride and sulfuric acid. After coloring materials were added, the concoction was poured into the mold where it set up after 12 hours. Such an aquarium must have weighed a ton and was dangerous to make, considering the sulfuric acid involved. All this just to conceal an aquarium frame!

Figure 1 was a perspective view of a roughly finished metal frame, Figure 2 was a vertical sectional view taken through the frame intermediate its ends and showing the first step in the process, Figure 3 was a fragmentary perspective view of one end of the frame, Figure 4 was a fragmentary view of the frame after the forms had been installed and 5 was a perspective view of the completed article. As the figures afford a good idea of what the patent is all about it and how it works, further details are not included here.

[Figure 94, *Aquarium*, Number 1838215] Adolph de Clairmont patented a divided tank in 1931 that was designed to hold living as well as non-living creatures. This made some sense, since dead animals such as corals could be placed in the waterless rear compartment, while live fish disported in the front one. The rear compartment could also contain items or models of other objects, thus turning the tank into an exhibit for educational purposes.

Figure 1 was a perspective view of an aquarium constructed in accordance with the present invention, Fig. 2 was a vertical front to rear sectional view, Fig. 3 was a perspective view illustrating one end of a second form of aquarium, Fig. 4 was a similar view illustrating a third form of the invention, Fig. 5 was a perspective view of a fourth form of the invention and Fig. 6 was a vertical sectional view through Fig. 5.

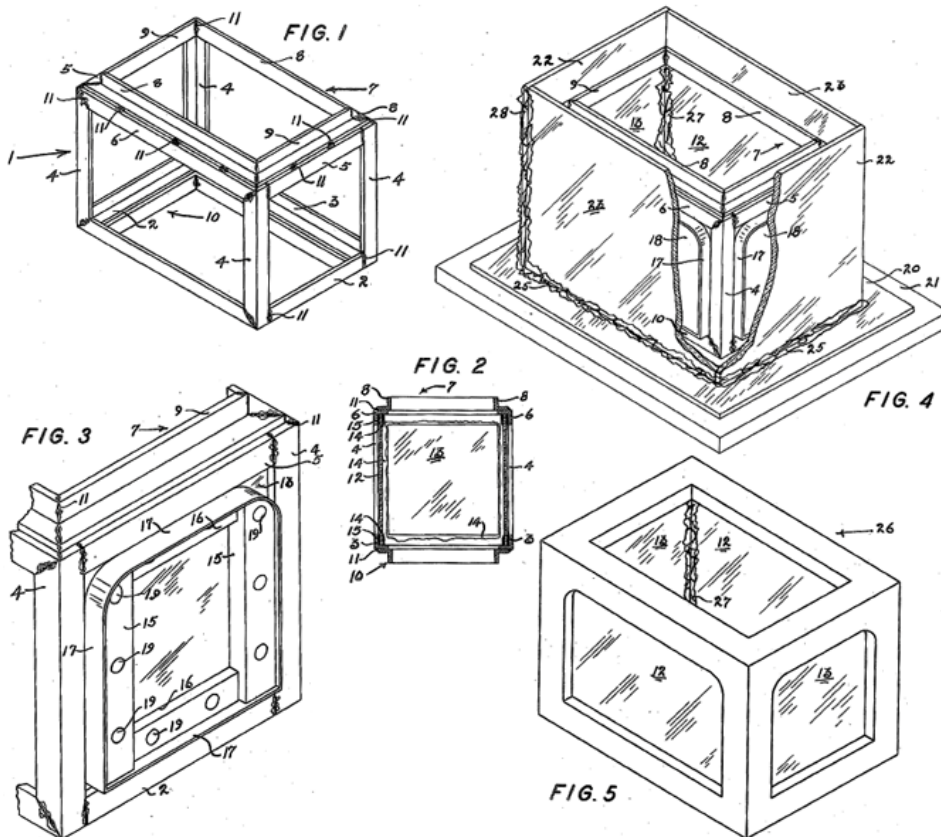

Figure 93: Clark H. Hogan's concealed frame aquarium, 1935.

When the interior of the aquarium was viewed through the front wall of the tank A, the exhibit in the case B would be visible through the water in the tank and would, in fact, appear to be submerged in the water and thus the fish and the like contained in the tank would appear to move in their natural surroundings.

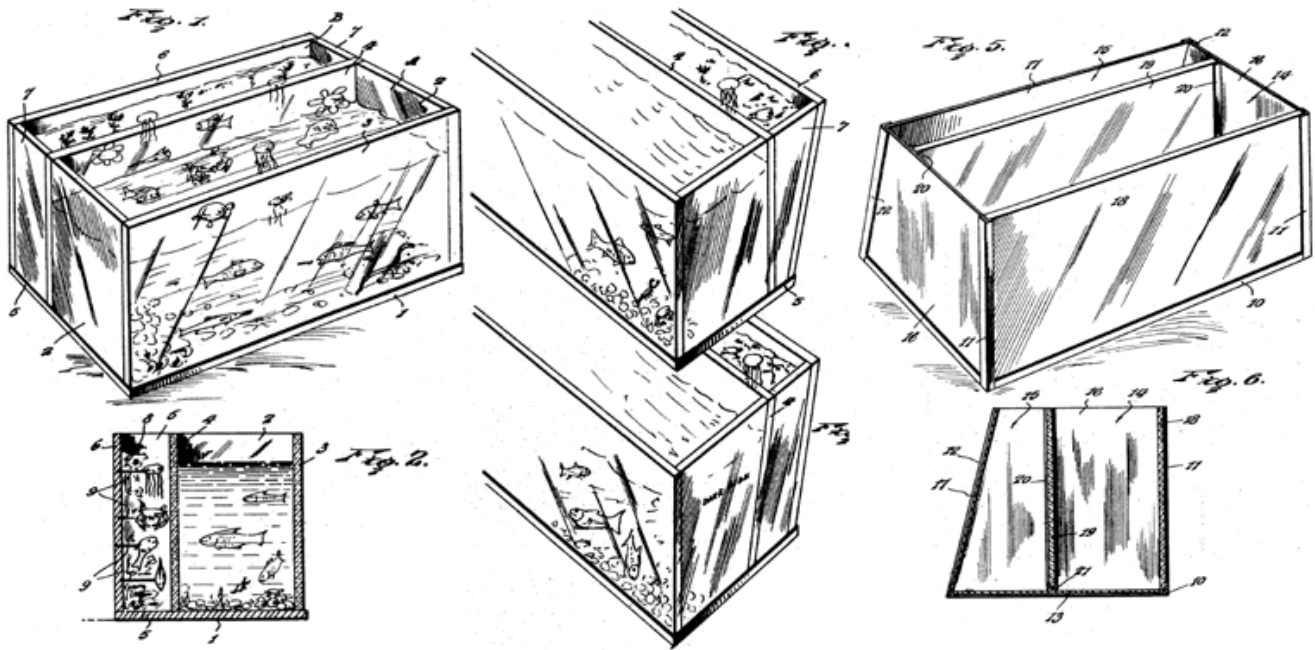

Figure 94: Adolph de Clairmont's divided tank, 1931.

Where the wall of the case **B** was of transparent material or even of translucent material, a light passing through would so illuminate the exhibit within the case so that transparent elements, such for example as jelly-fish and the like, would be so illuminated as to give a clear idea as to their structure.

[Figure 95, *Aerating Device*, Number 2008369] Aeration was a popular subject in this decade. The first such device was a patent granted to Harrison L. Stanley of Martinsville, Tennessee in 1931. Staley's claim was, "In my experimentation, I have discovered that if an open top vessel be inverted and, in this position, submerged in an aquarium so as to imprison a quantity of air within the body of the vessel and below the surface of the water, sufficient air would be dissolved by the pressure of the water against the imprisoned air to sustain fish life over a long period of time." However, considering the slight difference in water pressure between the top of the tank and the bottom, the amount of oxygen could be absorbed was almost immeasurable. Furthermore, there was little circulation to transfer the oxygenated water to the main part of the tank. In order to sink the holder on the bottom it had to be made very heavy, so in effect Stanley had produced nothing more than an interesting aquatic paperweight!

Figure 1 shows a sectional view of the aerator, Figure 2 is a perspective view of the same device, Figure 3 is a sectional view of the invention placed in operative position in a fish aquarium, the side wall of which is partly removed, and Figure 4 is a sectional view of a second form of the invention.

The numeral **1** designated the body of the aerator, made of non-corroding metal, earthenware or glass and in various decorative shapes such as diving bells, shells, castles etc. The body was provided with a chamber **2** which, when submerged below the surface of the water in an upright position, would imprison a quantity of air within the chamber **2** in direct contact with water **10**. The body had sufficient weight within itself to hold it on the bottom of the aquarium **11** by gravity.

As it was necessary to recharge the aerator with a supply of fresh air from time to time by withdrawing it from water, means were provided for accomplishing this without the introduction of the hand into the water of the aquarium. Ear **3** was fixedly secured on top of the body and had an opening **4** for the introduction of a wire hook or chain with which to withdraw the aerator from the water. Ear **3** was placed vertically above the center of gravity of the body so

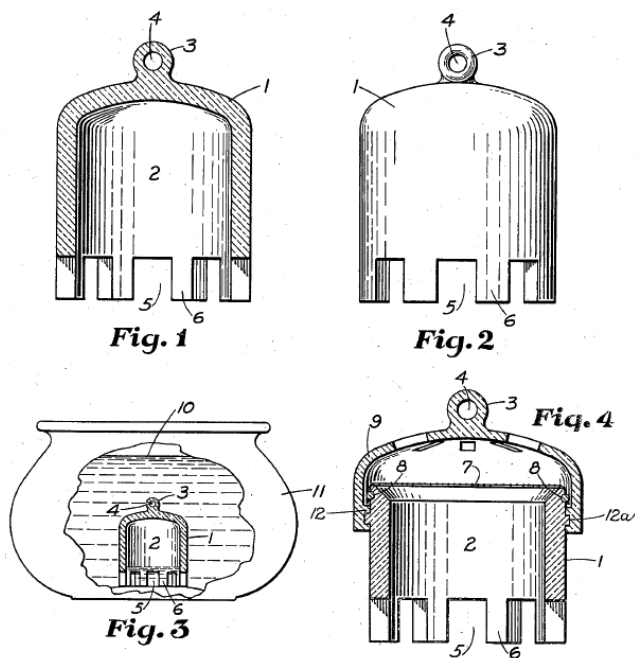

Figure 95: Harrison L. Stanley's aerator, 1931.

that when the body was suspended by hook or chain, it would maintain a vertical position. Unless the aerator was suspended vertically above its center of gravity when being introduced into the water, large air bubbles would escape from the air chamber 2, which greatly lessens its aerating capacity. On the lower portion of the body, openings 5 were provided to permit the agitation of water to be carried into the open end of the aerator. The agitation produced by the swimming fish was necessary for the rapid dissolution and diffusion of the dissolved air and if openings 5 were large enough for a swimming fish to pass through, such dissolution and diffusion of air was greatly expedited. The openings 5 were, in fact, spaces between legs the 6 on which the aerator rests.

In the second form of the invention shown in Figure 4, the numeral 7 indicates a permeable septum which was secured over the top opening in body 1. Septum 7 was removably attached to the body by any practical means, but preferably by securing the outer edge of septum 7 in an annular groove 8 by a cord or spring clasp. A perforated guard 9 was removably secured by engaging lugs 12.

In operation, the aerator was suspended by ear 3 which brings the aerator into a vertical position 5 and

while in this position it was submerged in the water of aquarium. This movement imprisoned a quantity of air in chamber 2 and brought it in direct contact with the water. Then, as fish consumed the dissolved air in water, dissolution of the air from chamber 2 continued until the air in the chamber was exhausted when it was necessary to recharge the aerator again by withdrawing it from the aquarium. When a permeable septum 7 was used in an aerator of this type (see Figure 4), the air in chamber 2 is dissolved also through the septum. All water which could percolate through septum 7 gravitated to the bottom of the aerator to commingle with the water pressing against the air, and as the percolated water was completely saturated with dissolved air it was immediately available for fish life by diffusion through the lower open end of the aerator.

Figure 96, Aquarium, Number 1939583] In 1932 William Welshausen of Allenhurst, New Jersey patented an aquarium that had a built-in heater and aerator. One of the objects of his invention was to “provide a novel aerating valve having a sump that may be easily reached to empty any water leaking past the aerating valve without disturbing the aquarium.” The thermostat was separate from the heater, so three holes had to be drilled into the bottom of the aquarium. Welshausen made much of the waterproof sump for the aerator but oddly enough failed to mention the possibility of leakage around the heater and the thermostat, two areas just as likely to leak. As we all know, the fewer holes drilled into an aquarium below its water level, the better!

Figure 1 was a longitudinal section through an aquarium equipped with the aerating valve and Figure 2 was an enlarged detail section through the aerating valve shown in Figure 1.

Figure 97, Apparatus for Aerating Aquariums, Number 1945962] In 1934 Michael Arneth of New Britain, Connecticut reinvented the wheel – albeit a more complicated one - with his aeration device. Although the diagram looks complicated, it simply consisted of two containers situated one over the other on a stand located next to an aquarium. The top one

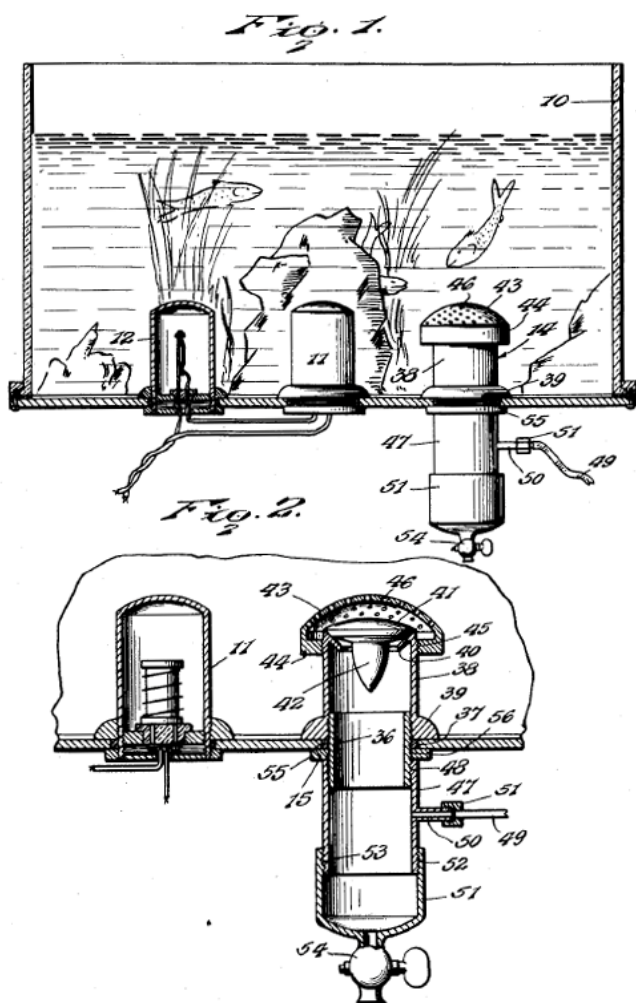

Figure 96: William Welshausen's aerator and heater, 1932.

was filled with water and, as the water dropped to the lower container, a venturi action produced an air current that was sent to the aquarium. After the top container was empty, the containers were simply rotated and the action restarted so there was no need to replace the water once one of the containers was filled. As the inventor stated: "With a few quarts of water for the change, the apparatus is adapted to maintain continuous operation in delivering air to the tank for a few hours."

Figure 1 is a front elevation of one form of apparatus for aerating an aquarium, one end of the tank being also shown; Fig. 2 is a side elevation of the same, Fig. 3 shows an enlarged view of the bearing structure, Fig. 4 shows parts of one of the check valves, Fig. 5 is a front elevation of a modification, Fig. 6 is

a side view of the same, Fig. 7 shows another modification, involving the use of glass for the containers, Fig. 8 is a fragmentary view of another modification in which the valves were restricted to check valves and Fig. 9 is another view of the same.

With the upper container (10 in the Figures 1 and 2) charged with water, the water would fall into the lower container and tend to displace the air therein for delivery to the aquarium tank with a proper setting of the valves. After the emptying of the upper container the moving structure could be rotated so as to inter-change the containers for resumption of operations, all without recharging for an indefinite period of time. With a few quarts of water for the charge the apparatus was adapted to maintain continuous operation in delivering air to the tank for a few hours. Under operating conditions the tube (30 in Figure 1) received water from the upper container and delivered the same to the upper end of the lower container and above the water line therein. This tube was in the form of a single straight continuously

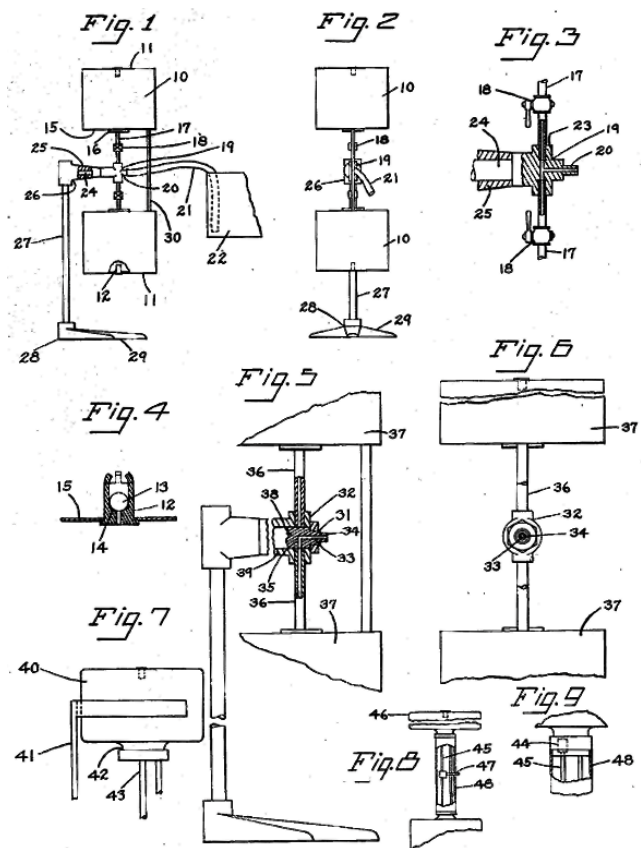

Figure 97: Michael Arneth's aeration device, 1934.

open structure, being free of any and all forms of valves or cocks or the like.

By opening into what could be described as the air end of the lower container there was involved a minimum of hydraulic pressure effect. The water received fell through the air space in the lower container and was deposited at the bottom portion thereof virtually at the water line, which line gradually rises. The air in the lower container was thus displaced and was guided by the air delivery means to the tank. The water delivery lacked anything suggestive of forced ejection, the air being merely displaced by the deposited water. By the use of the single valveless tube 30 there was eliminated any and all need of special parts and special manipulation of the air displacement detail in changing the containers around between the alternative positions or reversing the containers. The device was especially adapted for use in connection with aquariums of household form or small sized goldfish tanks or the like.

[Figure 98, *Aquarium Air Supply*, Number 2008363] James B. Maris of Glen Ridge New Jersey, well-known for his aquarium induction air pump, improved upon the Welshausen aerator in 1934 in that it didn't need to have a hole drilled in the bottom of the tank. Maris used tubing that could be bent to conform to the desired location of the air stone, and placed the air stone at the bottom of the tank to maximize oxygenation and water circulation. Prior air stone designs were simply inserted into the tank, affording limited control over their position.

Figure 1 is a view in front elevation, and partly in vertical section

of an aquarium, with an aerating device in the construction of which the invention has been embodied; Fig. 2 is a fragmentary, detail view in plan, partly in horizontal section, of a delivery means and its support of the type illustrated in Fig. 1, taken, separately, and on a larger scale; Fig. 3 is a vertical sectional view, taken on the plane indicated by the line III - III of Fig. 4, and viewed in the direction of the arrows at the ends of the line, illustrating a modification of the delivery means; Fig. 4 is a view in bottom plan of the modified form of delivery means shown in Fig. 3 with a fragment of conduit 10 attached and Fig. 5 is

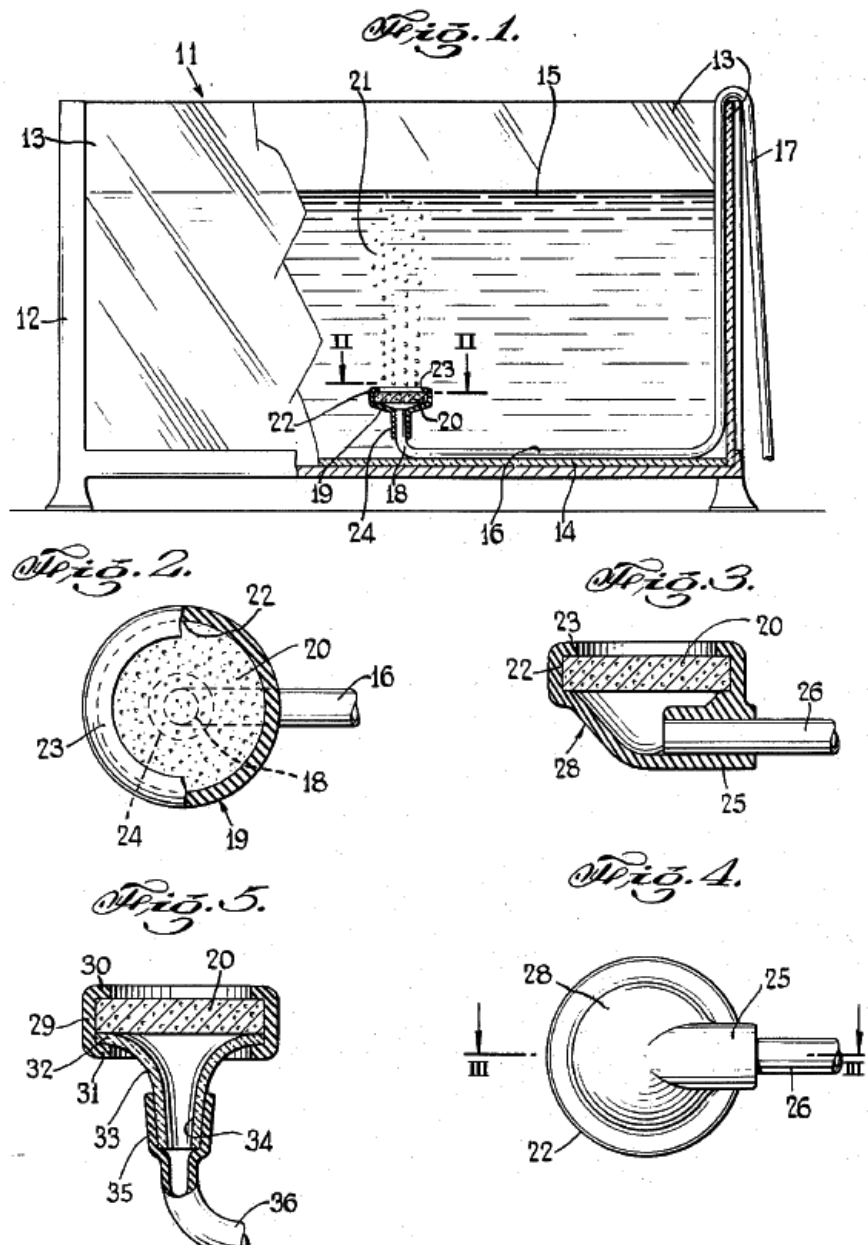

Figure 98: James B. Maris' aerator, 1934.

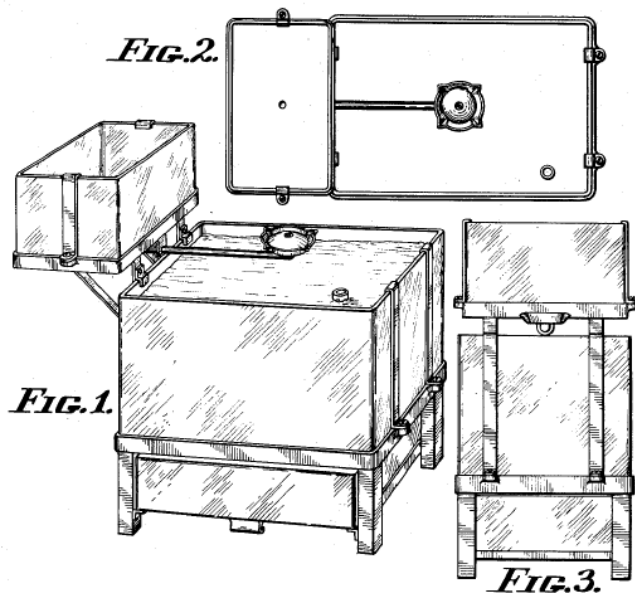

Figure 99: William P. Gold's aeration scheme, 1935.

a view in vertical section of another modification of the delivery means, with an attached conduit shown partly in section and partly in elevation.

[Figure 99, *Design for an Aquarium*, Number D96540] A variation on using the difference in water height to power a device to aerate water was patented by William P. Gold of Clifton, Kentucky in 1935. The water ran out of the upper tank onto a round plate where the water sprayed upwards or just ran down into the main tank, aerating it as it flowed. This is was a Design Patent but the inventor, although numbering the figures made no comment whatsoever on his invention! Figure 1 is a front perspective view of the aquarium showing the invention, Figure 2 is a plan view and Figure 3 is a side elevation.

[Figure 100, *Aquarium*, Number 2028913] Another unusual tank was that designed by Paul Neumann of Milwaukee in 1936. Below a cylindrical aquarium, Neumann positioned a two-compartment tank. Although this tank looked like two pans soldered together, they were separated, connected only by a short pipe containing a valve. Below this was an air tank, filled at intervals via a bicycle pump. The com-

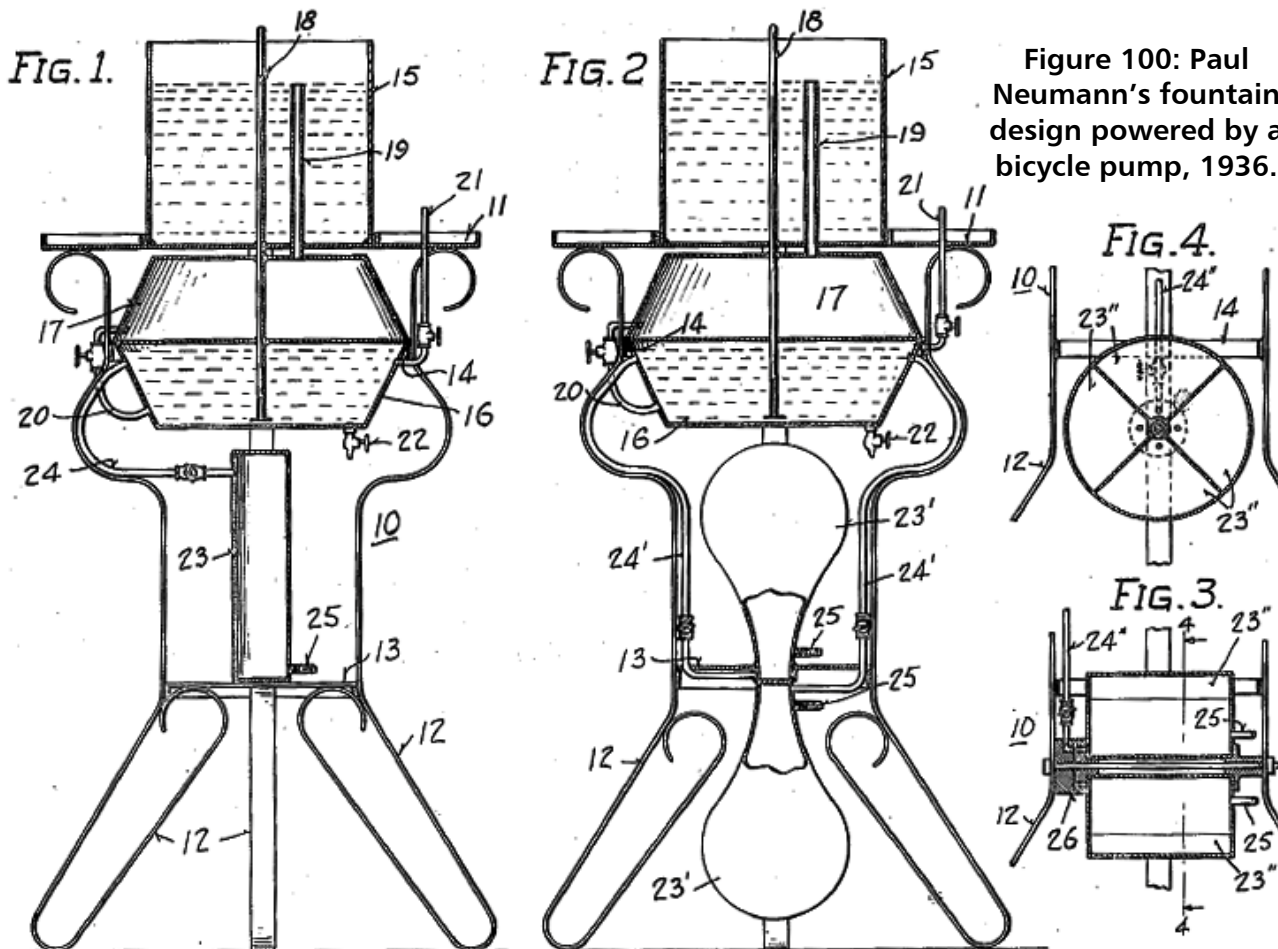

Figure 100: Paul Neumann's fountain design powered by a bicycle pump, 1936.

pressed air forced the water from the lower half into the aquarium where it spouted like a fountain. The overflow then drained into the upper half of the two-compartment tank. When the lower compartment was empty, the air was shut off and the water drained into the lower compartment.

Figure 1 was a view in vertical section of an aquarium constructed in accordance with the invention, Fig. 2 was a view in vertical section of a modified form of the aquarium, Fig. 3 was a view in vertical section of a modification of compressed air reservoirs and connecting means and Fig. 4 was a view in vertical section taken along the line 4 - 4 of Fig. 3.

Referring to Figs. 1 and 2 in particular, a frame or standard **10** was shown carrying a tray **11**. The frame illustrated was fabricated from four legs **12** formed from sheet metal and two transverse members **13** and **14** connected to the legs in any suitable manner such as by welding or soldering. The legs could be of any suitable shape and were preferably formed with a view to giving the structure an artistic appearance. The tray was seated on the upper ends of the legs and carried a water bowl **15** in which fish could be kept. The tray, in addition to carrying the water bowl, helped to brace the legs so as to make the whole structure strong and rigid.

A water storage tank **16** and a drain receptacle **17** were placed under the tray and supported from the transverse member **14**. A fountain nozzle **18** extended from the storage tank through the drain receptacle, tray **11** and water bowl **15**. This nozzle was placed centrally of the water bowl which was large enough to catch the water that was discharged. A drain pipe **19** extended from the drain receptacle **17** to a predetermined level in the bowl. The height of the drain pipe would control the level of the water in the bowl. A valve controlled connection **20** was provided between the drain receptacle and water storage tank **16**. This gave the desired communication between the receptacle and tank for the transfer of water and to facilitate the washing of them.

A valve controlled air vent **21** was provided in the water storage tank to facilitate the transfer of water

from the receptacle **17** to the tank **16**. The tank was also provided with a drain **22** so that the water could be drawn off when desired. In order to provide pressure for discharging the water from the storage tank **16** through the fountain nozzle **18**, a compressed air reservoir **23** was mounted on the transverse member **13** and connected to the storage tank **16** through a valve controlled tube **24**. The reservoir **23** was provided with a valve fitting **25** similar to that provided in the inner tubes of automobile tires. This permitted the storing of compressed air in the reservoir **23**. In the modified form illustrated in Fig. 2, two compressed air reservoirs **23'** were provided. In this manner if reservoirs of the same capacity as **23** were employed, provision could be made for operating the fountain three or four times as long as in the structure shown in Fig. 1.

In the operation of the aquarium, water was poured into the bowl until the drain receptacle was filled and the water level was raised to the top of the drain pipe. The air vent **21** and the valve controlled connection **20** were then opened and water permitted to flow from the drain receptacle **17** to the storage tank **16**. The air vent **21** and valve controlled connection **20** were then closed. Air was pumped into the compressed air reservoir **23** until the desired pressure was established. The pressure could be ascertained in the same manner as the pressure was measured in the ordinary automobile tire. Air was then permitted to flow through the controlled air tube **24** into the storage tank, developing a pressure that was sufficient to cause the water to flow upwardly through the fountain nozzle **18**. As the water fell back in the form of a spray, it was aerated. This aerating of the water restored to it the air that had been taken out by the fish.

When it was desired to wash out the receptacle **17** and storage tank **16**, the air vent **21** and valve controlled connection **20** were opened and water poured down the drain pipe **19**. The water used in washing was drawn off through the drain **22**. The functioning of the aquarium disclosed in Fig. 2 was the same as that disclosed in Fig. 1 with the exception that when the air supply from one reservoir was exhausted, the other was utilized. In the structure illustrated in Figs. 3 and 4, when the supply of air in one tank was ex-

hausted, the tanks were rotated, establishing communication between another tank and the storage reservoir 16.

[Figure 101, *Aquarium*, Number 1956524] A far simpler device for aerating was that designed by Stanley H. Byram of Martinsville, Indiana in 1936 and assigned to Grassyfork Fisheries, Martinsville, Indiana. It consisted of an inner tube and an outer tube, the latter containing holes for the incoming water to escape but preventing the fish from being swept out of the tank.

Fig. 1 was a perspective view of an aquarium equipped with inlet and outlet means constructed in accordance with the present invention; and Fig. 2 was an enlarged elevation of the outlet means, parts being shown in section for clarity of illustration.

In normal operation, liquid was introduced into the aquarium in a comparatively fine spray through the small ports in the spray pipe 37. If the ordinary type of level-maintaining outlet tube, comprising a single tube projecting upwardly to the level that it was desired to maintain and open at its so upper end, were used in conjunction with the above-described type of inlet means, the fresh water laid on the top of the body of water in the aquarium would be skimmed off by the outlet tube, leaving a large body of stagnant and unaerated water within the aquarium. Thus there was distinct cooperation between the particular type of inlet means and the particular type of outlet means described.

The ordinary type of outlet skims off the water that is high in oxygen content and leaves undisturbed the portions of the body of water that are high in carbon dioxide content. The construction of this invention, on the other hand, withdrew water from those areas in which the carbon dioxide content was high and left relatively undisturbed those portions of the water that were high in oxygen content. Since water was introduced to the aquarium at the surface and in a region remote from the outlet port which was adjacent the bottom of the body of the water, a very definite circulating flow of current would exist within

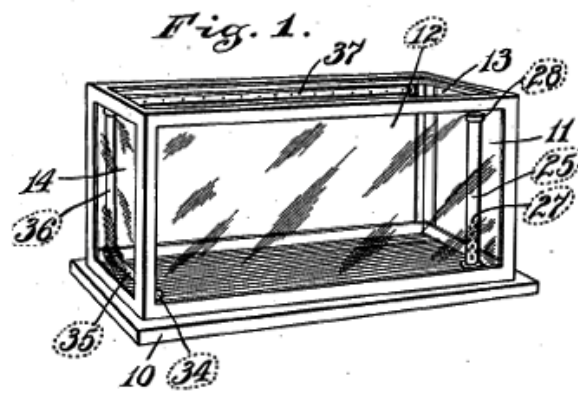

Fig. 2.

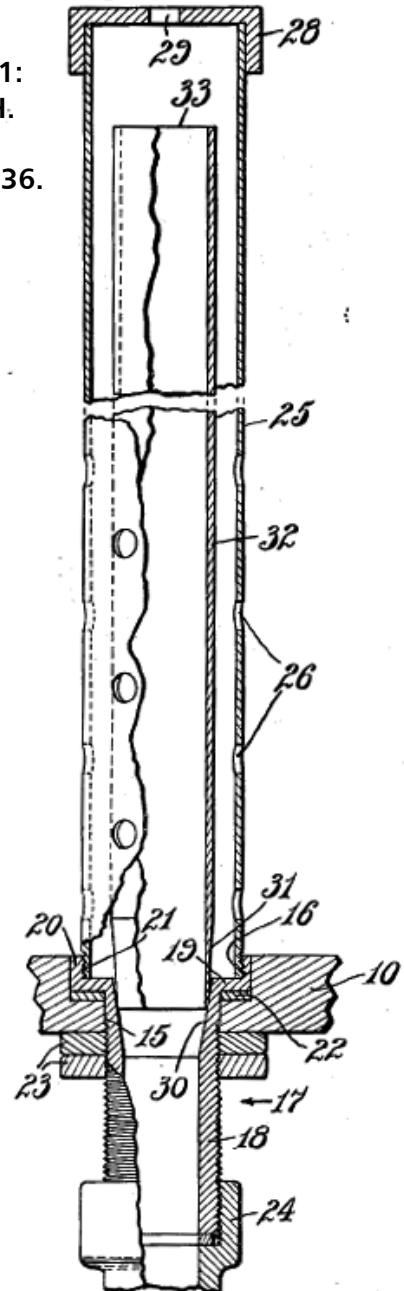

Figure 101:
Stanley H.
Byram's
aerator, 1936.

the aquarium. Since this current flowed from the surface of the water downwardly and toward the outlet, it had a decided tendency to scavenge from the bottom of the aquarium the droppings of the fish and to remove them from the aquarium. This action was decidedly advantageous since, if the droppings were permitted to accumulate in the aquarium they would eventually evolve gases that would rise in bubbles and escape from the surface of the liquid into the room.

[Figure 102, *Fish Feeding Device*, Number 1976962] Two feeding devices were patented during this decade. The first was by Herman G. Pape of New York City in 1934 and was designed to keep food from spreading throughout the tank. This device consisted of a tube into which the food was inserted, from which it fell down onto a feeding trough (Pape shows two variations). The assumption was that the food was (or would become when it became waterlogged in the tube) heavier than the water.

Figure 1 is a fragmentary sectional view taken on the line 1-1 of Fig. 2 of a conventional type of aquarium partially filled with water and having a fish feeding device embodying this invention in place therein, Fig. 2 is a sectional view and was taken on the line 2-2 of Fig. 1 and Fig. 3 is a sectional view of a modified type of fish feeding device embodying the invention in association with an aquarium.

As shown in Figs. 1 and 2, the feed trough consisted of a bowl made of suitable material having a curved side 1 suitably high to prevent food 2 therein from being washed out by the normal water turbulence caused by the fish or by natural water currents, but not so high or curved relative to the diameter of the bowl as to interfere with the fish having free access to the food therein or feeding freely therefrom. The bottom of the bowl has a raised portion 3 at the center, which served to spread the food so that it would be more readily accessible to the fish than would be the case if the food were bunched together at the center. The raised portion also tended to prevent the food from being washed out of the bowl, particularly in combination with the curved in-turned side 1.

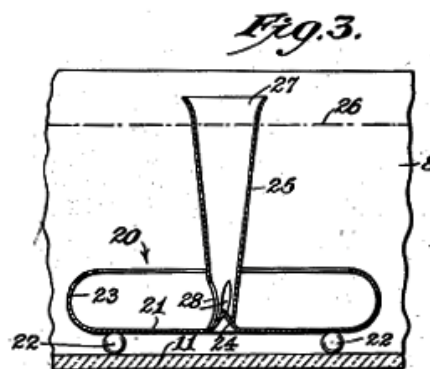
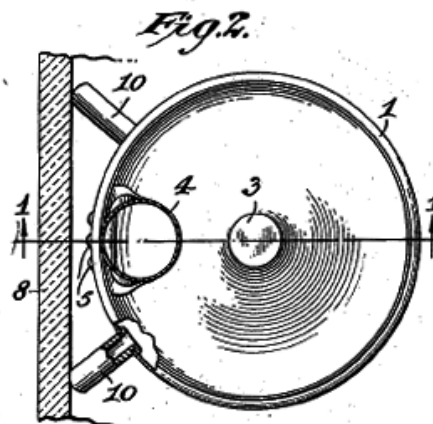
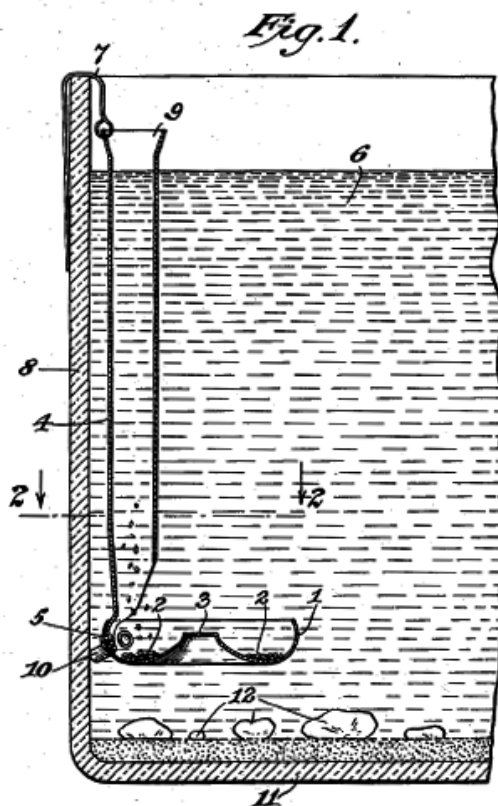
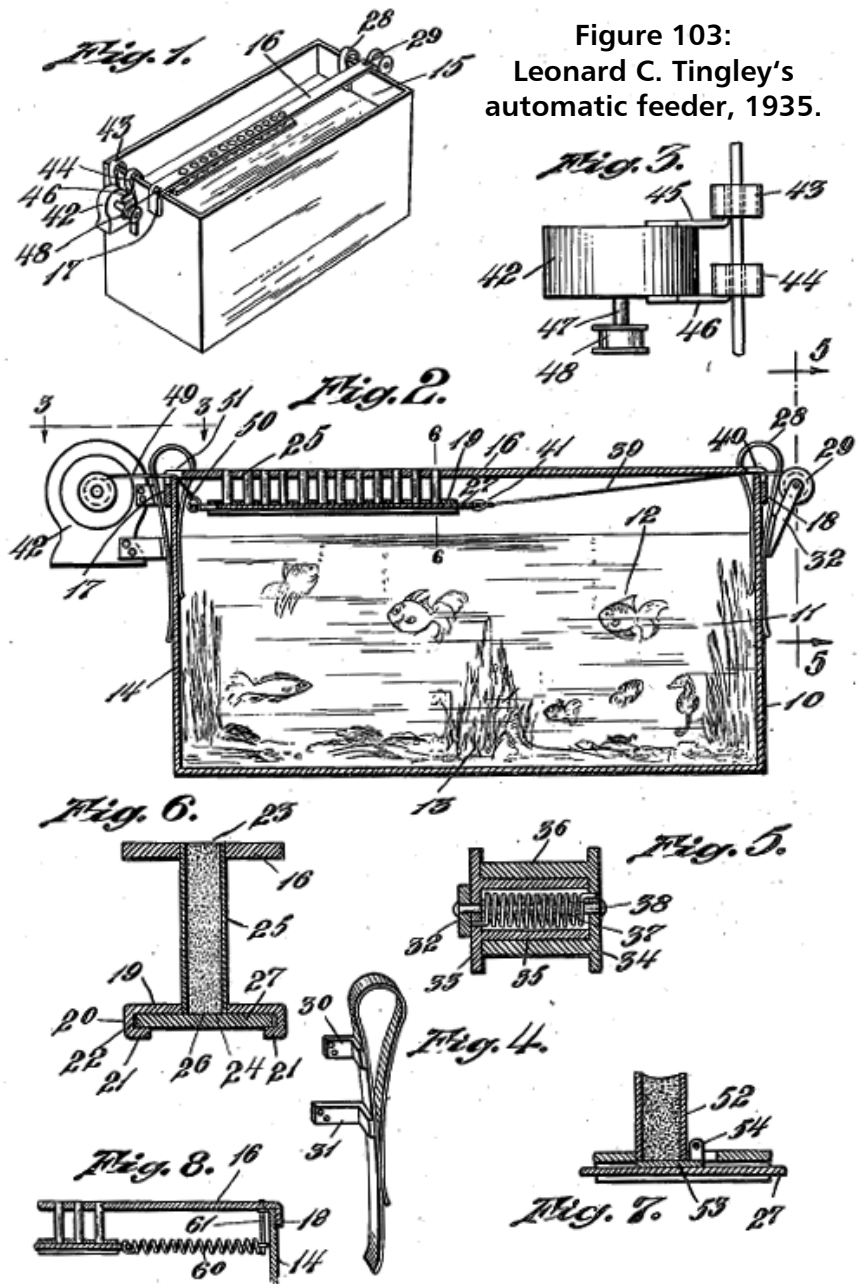

Figure 102:
Herman G. Pape's feeder, 1934.

A feed tube 4 was secured to one side of the bowl by any suitable means appropriate for the materials of which the bowl and tube were made, for instance rivets 5. Tube 4 extended upwardly from the trough to above the level of the water 6 in the aquarium in which the device was placed. The device could be supported in position by a pliable wire 7 secured at one end to the tube 4 and bent over and engaging the top of a side wall of the aquarium. The upper end of the tube was flared, as at 9, to facilitate the introduction of the fish food, and the lower end of the tube could be cut or formed to have an opening biased toward and extending into the bowl. If desired, spacer knobs or studs 10 could be secured to the trough on opposite sides of the tube juncture, as by riveting as shown, which kept the trough some distance from the aquarium wall, kept the tube and trough level and steadied the device against swinging or moving about in the water, and thus helped to maintain the food in the trough since if the trough were tilted or if the device were to swing or move in the water, the food would be more likely to wash or fall out of the trough and settle to the bottom of the aquarium. The spacers also tended to relieve the strain somewhat on the joint between the tube and trough.

[Figure 103, *Feeding Device*, Number 1989298] This was followed in 1935 by a device designed for automatic feeding by Leonard C. Tingley of Providence Rhode Island. The invention consisted of a narrow box that spanned the length of the aquarium, containing compartments that contained the food, the bottom being closed off by a slide with a hole in it. As the slide was pulled along (it was powered by an electric or clockwork motor) and the hole arrived beneath one of the compartments, the food was re-

Figure 103:
Leonard C. Tingley's
automatic feeder, 1935.



leased. The device could be removed easily from the tank, but the food box could only be half the length of the aquarium, since room had to be made for the slide when all the compartments were empty. Although capable of working, it definitely was a Rube Goldberg creation of the first order.

Fig. 1 was a perspective view of a tank or aquarium with the feeding device mounted thereon, Fig. 2 was a sectional view thru the feeding device and aquarium, Fig. 3 was a top plan view of the motor device and clips for mounting the same, Fig. 4 was a per-

spective view of one of the clips that were used for mounting the mechanism in position, Fig. 5 was a vertical sectional view taken on a plane defined by the line 5 - 5 of Fig. 2, Fig. 6 was a section on line 6 - 6 of Fig. 2, Fig. 7 was a sectional view similar to Fig. 2 of a detail and showing a modified construction and Fig. 8 was a fragmental sectional view of a modified form of construction.

The device was readily detachable from the tank and consisted of a supporting strip or plate 16 that was bent as at 17 at one end and at 18 at the other end to extend over the diametrically opposite edges of the tank. This strip 16 was of sufficient rigidity to support the parts that it carried but it was of sufficient flexibility to permit it to be bent at the desired point over the edge of the tank so that it could be adjustably attachable to tanks of varying lengths and widths as occasion could require and could be laterally adjustable. A second plate 19 was positioned below the supporting plate 16. The longitudinally-extending edges of this plate 19 were roiled downwardly and inwardly as at 20 to provide lips 21 forming a slideway 22 between the lips and the bottom of the plate for a closure controlling slide to be presently described.

The plates 16 and 19 were provided with aligned openings 23 and 24 receiving the tubes 25 that were secured therein and served to support the bottom plate from the top plate and also to provide pockets or compartments in which the feeding material could be deposited. Each pocket or compartment could be discharged through its lower open end 26 by the material dropping by gravity. These discharge openings were closed by a slide 27 of a width that extended between the opposite downwardly extending portions of the plate 19 and of a thickness to engage the lower surface of the plate 19 when supported by the lips 21. The slide 27 extended the entire length of the discharge pockets and closed all of them. They could, however, be opened by pulling the slide out from beneath one pocket at a time so that the contents could be discharged into the tank. The pockets that were provided were all in a straight line and equally spaced apart although various other arrangements could be provided if so desired.

In order that this movement could be controlled to operate at periodic intervals, the operating means was completed by use of some suitable device for this purpose. This consisted of a clock or an electric motor with time control, the details of which were not a part of the invention but was known as a Telechron movement. This device 42 was adjustably supported upon the tank by a pair of clips 43 and 44 through brackets 45 and 46 and was provided with a shaft 47 having a pulley 48 thereon. Secured to the pulley and extending about the same was a flexible element 49 that was secured at 50 to the end of the slide 27 by extending through an opening 51.

[Figure 104, *Thermostat for Aquariums*, Number 1981251] George F. Roth of Chicago devised a real improvement on thermostats in 1931. As aquarists well know, if the contacts on a thermostat stick together, the heat remains on and the fish are cooked.

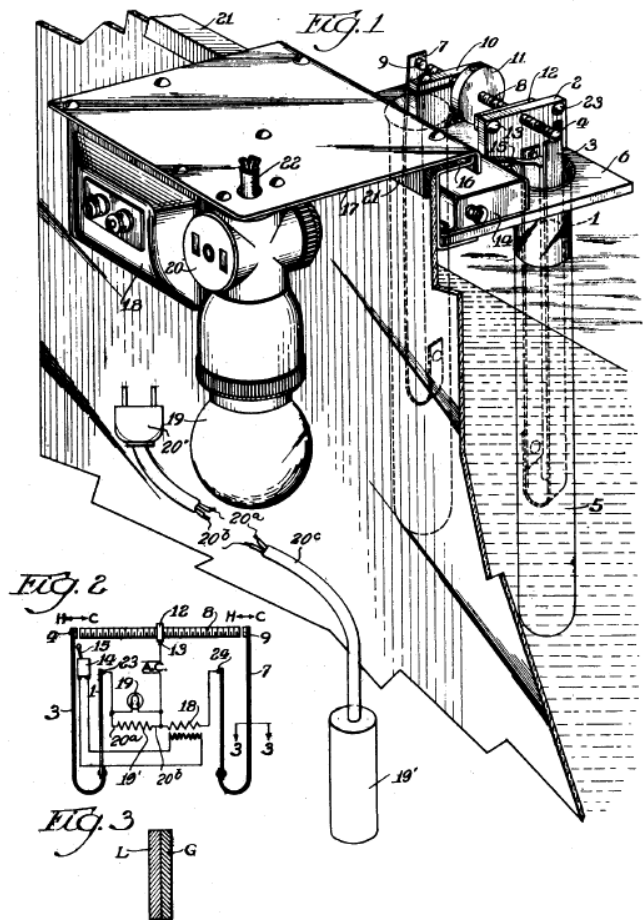

Figure 104: George F. Roth's fail-proof thermostat, 1931

Roth's improvement was to incorporate a secondary thermostat set a few degrees higher than the primary one. The secondary thermostat operated an electromagnetic vibrator that freed the frozen contacts of the primary thermostat. This was an extremely innovative solution to the main problem of early aquarium heater thermostats. The lamp in the drawing was used only to show when the heater was on or off.

Figure 1 is a fragmentary perspective view of an aquarium with a temperature control device mounted on the front edge of the tank, the electric heater element being shown disconnected at the plug attachment; Fig. 2 is a circuit diagram of the temperature control device and Fig. 3 is an enlarged section on the line 3 - 3 of either thermostat as shown in Fig. 2. A bi-metallic U-shaped thermostat 1, referred to as the primary thermostat, was fixedly mounted on a vertical support 2 and comprised a movable arm 3 the free end of which had a contact 4 mounted thereon. The thermostat comprised an inner strip G and an outer strip L (shown in Fig. 3), the strip or element located on the outer side having the lesser coefficient of expansion.

If in operation it was required that the water in the aquarium had to be maintained at about 70° and the temperature of the water dropped below that point, the thermo-responsive element 3 drew toward 10 the contact 8, which was so adjusted that the contact 4 on the element 3 engaged with the contact 8 and closed an electrical circuit that turned on the heater 19' located at the bottom of the tank. The lamp 19 was connected in parallel with 16 the heater 19' so that as soon as a contact was made at 4 - 8 the lamp lighted showing that the heater turned on. When the temperature of the water reached 70° the contact broke at 4.

The process was repeated over again as soon as the temperature of the water receded. If the contact 4 of the thermostat 1 froze or adhered abnormally to contact 8, as sometimes happened, and did not break contact when the temperature of the water reached 70° then the thermostat 7 that was set to close at a few degrees higher swung against the other end of contact 8. When this contact was made, say at 75°, it

closed a vibrator operating circuit. Current now passed through the transformer 18 to the electromagnetic device 14, causing it to vibrate its arm 15 against the thermo-responsive element 3, breaking the contact 4 - 8 and thereby opening the heater circuit. Ensuing drop in temperature then broke the contact made at 8 - 9 by thermostat 7. If contact 9 stuck, the continued operation of vibrator 14 served as an alarm, whereupon the contact 9 could be broken manually. By adjusting the contact 8 so that the gap between the end of the contact 8 and the contact 4 was made smaller, the gap between the other end of contact 8 and contact 9 was made larger. Therefore the thermostats could be set for any definite range of temperature.

[Figure 105, *Heating and Illuminating Device for Fish Aquariums, Number 1803571*] Before thermostatic heaters were available for aquaria, light bulb heaters were common. One design in 1931 was created by John J. Ulman of Cleveland. The tube used

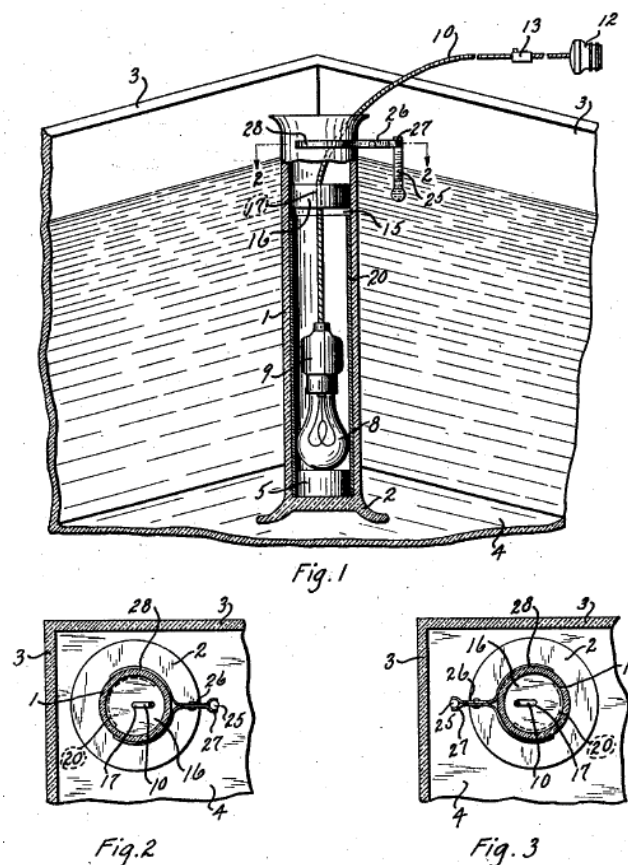

Figure 105:
John J. Ulman's light bulb heater, 1931.

was of glass so it also served to illuminate the aquarium, although this position was unsuitable for the fish and for the aquarist as well. I probably need not comment on the safety of such an arrangement, but aquarists did take chances in those days.

Fig. 1 was a vertical sectional view of the device arranged in one corner of a fish tank; Fig. 2 was a cross sectional view on the line 2 - 2, Fig. 1, showing the device in its normal day-time position and Fig. 3 was a similar view showing the device in its normal night-time position.

The device included a tubular glass container 1 provided with a suitable base 2 and open at its top and closed at its bottom. The container was of a height greater than the depth of the liquid in the tank in which it was adapted to be used, such a tank with glass sides 3 and a glass bottom 4 being shown in the drawings. To maintain the device in the proper position in the tank against the buoying effect of the water in the tank, such as in one corner, a suitable weight 5 was placed in the bottom of the container as indicated.

Resting on the top of this weight was an ordinary electric light bulb 8 which constituted the heating and illuminating means, the bulb being of such candle power as to readily maintain the water of the tank at the proper temperature. The bulb was secured to an ordinary socket 9 connected to one end of a suitable current transmitting cord 10 extending through the open top of the container and provided at its other end with the usual plug 12 and intermediate its ends with a suitable controlling switch 13.

A heating and illuminating chamber 15 was therefore formed within the container, the upper end of which chamber was closed by a suitable closure 16 of felt or the like, so that it was moisture-proof, the closure having a small central opening 17 through which the cord 10 extended.

Arranged within and almost as high as the heating and illuminating chamber 15 was a reflector member 20 having a transverse curvature corresponding to the curvature of the tubular container 1. This reflec-

tor had a highly polished inner surface so that it readily reflected the light rays. In its normal daytime position, as indicated in Figs. 1 and 2, it served to reflect the light rays inwardly toward the center of the tank and thus make visible the fish in the tank, and when it was in its normal night-time position, indicated in Fig. 3, it served as a shield to cut off the light rays and protect the fish from any glare of the light. Either this reflector 20 could be adjusted or the container itself could be turned, the latter being possibly more convenient. In practice, the reflector 20 could be a simple sheet of aluminum. In order that there would be no doubt as to what the temperature of the water of the tank actually was, a simple thermometer 25 was provided.

[Figure 106, *Aquarium*, Number 2016123] In 1935 Wallace Schorr of Morningside Minnesota devised a far safer scheme (*Aquarium*, Number 2016123). In Schorr's design the lamps were not immersed in the water so the danger of electric shock was much less. The lamps, as in Ulman's design, provided both heat and light although once again, the placement of the lights was not optimal.

Fig. 1 is a view partly in front elevation and partly in vertical longitudinal section of an aquarium embodying the invention, Fig. 2 is a view partly in plan and partly in horizontal section, Fig. 3 is an end view, Fig. 4 is a vertical section taken on the line 4 - 4 of Fig. 2 as indicated by the arrows, Fig. 5 is a rear view of a portion of the aquarium, Fig. 6 is a view partly in front elevation and partly in vertical section illustrating a modified form of aquarium, the glass tanks used therewith being indicated in dotted lines; Fig. 7 is a view partly in plan and partly in horizontal section illustrating the aquarium shown in Fig. 6, Fig. 8 is an end view of the same, Fig. 9 is a vertical section taken on the line 9 - 9 of Fig. 7 and Fig. 10 is a view in rear elevation illustrating a portion of the aquarium shown in Figs. 6 to 9.

By turning on the switches 33, electricity would be supplied to the bulbs 32 to light them. These bulbs located in the substantially closed chambers 29 had the double function of lighting two adjacent tanks 11 and 12, so as to permit the fish to be readily viewed

and of supplying heat to the chamber 29 so as to heat the water in these two tanks. The side walls of the

chambers 29 were formed by adjacent ends of tanks 11 and 12 and heat was transmitted both by radiation and conduction from the chambers 29 to the water in the tanks. The temperature of the tanks could be regulated when the lights 32 were on by means of the dampers 38. When the dampers 38 were opened, fresh air could enter the chambers 29 through the air inlets 36 and heated air could exhaust from the chambers through the air outlets 37. The settings of the dampers 38 determined the rapidity of air circulation through the chambers 29. As the bulbs 32 were located directly behind the front uprights 18, the tanks were indirectly lit up as observed from the front of the tanks and the beams from these lights shone on the fish and other marine life held within the tanks so as to produce beautiful effects.

[Figure 107, *Plant Propagator, etc., or Aquarium, Number 107-2002380*] The creation of Gilbert Wernicke and Alfred R. Lintern of Cleveland, Ohio in 1935 featured electrical resistance heating elements concealed below the bottom of the tank. They show two different tank designs in their drawings, one of which has a curved decorative glass top. In addition to electrical resistance heating elements, they also suggested a tubular lamp that could be used for heating the tank (or lighting if just the propagation of plants was the object).

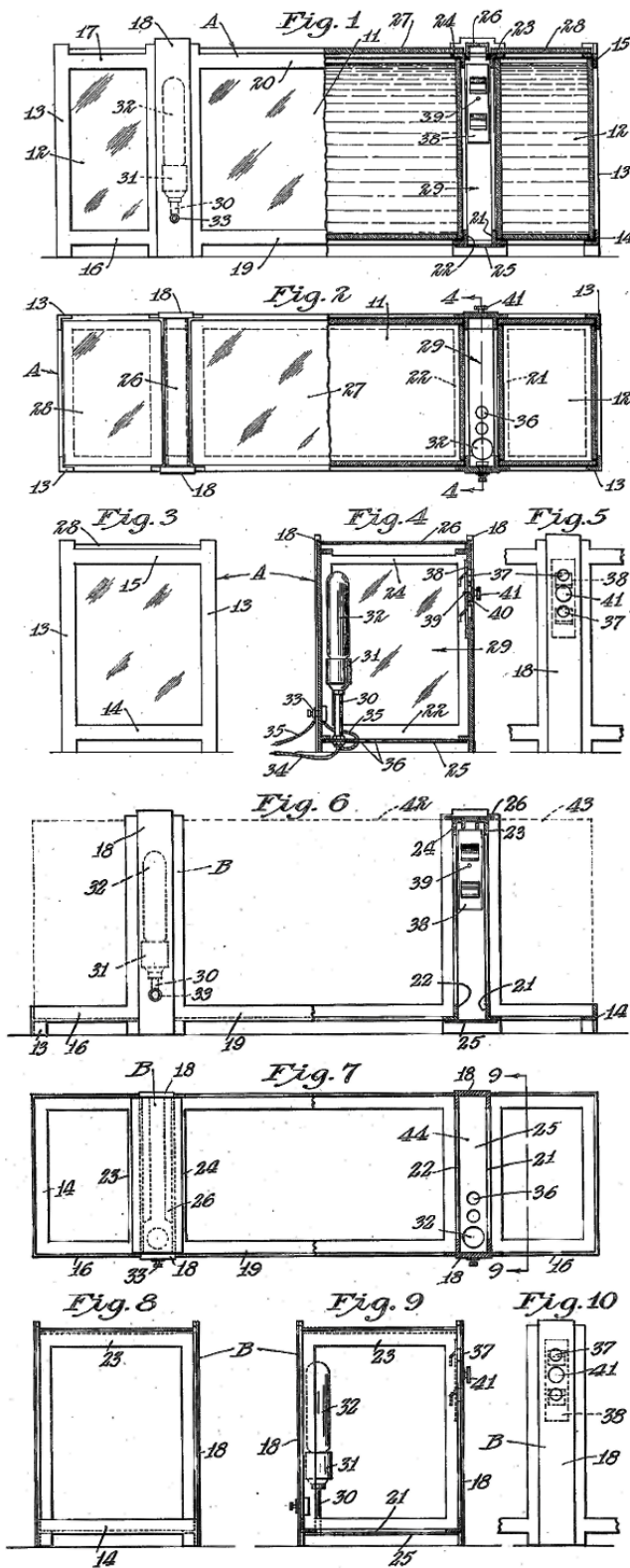

Figure 106:
Wallace Schorr's light bulb heater, 1935.

tion and heating device, Fig. 9 is a fragmentary perspective view showing still another arrangement of frame members at the base and a modified corner construction, and Fig. 10 is a fragmentary sectional view of still another modification of base.

The main body of the patent is long (five pages!), but as the figures afford a good idea of what the patent is all about it and how it works, it is not included here.

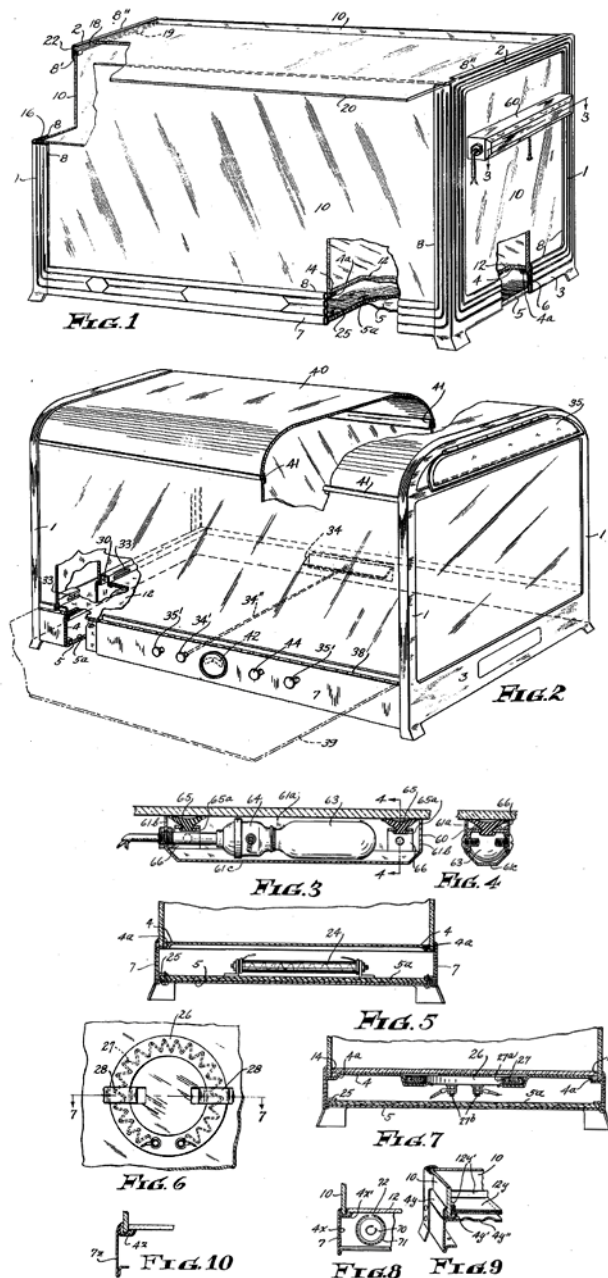

Figure 107:
Gilbert Wernicke and Alfred R. Lintern's
heated aquariums, 1935

[Figure 108, *Transporting Aquarium for Aquatic Animals*, Number 1991149] Leaving nothing left to waste, including the air rushing alongside a moving automobile, Albert S. Haislip of Fredericksburg, Vermont patented a novel fish transportation device in 1935. The idea must have come to him as he watched his dog with its head stuck out of the window. Haislip replaced the dog with a funnel, to which was connected a hose that led to a fish can. As the automobile moved along, air would be compressed and sent to the can, thus aerating it. Score ten points for imagination for Albert Haislip!

Figure 1 is a fragmentary side view of an automobile showing the manner in which the contrivance is placed in an automobile, Figure 2 is a side elevational view of the container or aquarium as constructed in accordance with the principles of the invention, Figure 3 is a top plan view of Figure 2, Figure 4 is an enlarged top plan view of the special lid or cover and its air conditioning and cooling coil, Figure 5 is a bottom plan view of the cover shown in Figure 4, Figure 6 is an enlarged sectional view taken approximately on the plane of the line 6 - 6 of Figure 3, Figure 7 is a fragmentary detail view in section showing a valved by-pass for the incoming air currents, the section being on the line 7 - 7 of Figure 5, Figure 8 is an enlarged sectional view showing the air intake funnel or cup, Figure 9 is a detail elevational view of a buoyant cartridge designed for temporary use during the period of fishing and placing the resultant catch in the container, Figure 10 is a view like Figure 9 showing the bottom cap removed, Figure 11 is a central longitudinal sectional view taken approximately on the plane of the line 11 - 11 of Figure 9, looking in the direction of the arrows and Figure 12 is a horizontal section on the line 12 - 12 of Figure 10.

[Figure 109, *Illusion Apparatus*, Number 1764356] Two odd contraptions finish off this section of utilitarian patents. The first was awarded to Elmer E. Schlotz of Denver, Colorado in 1930. This was an illusion apparatus designed to entertain an audience in a theater by making it appear that the performers move and act in a body of water. The diagram is fairly self-explanatory, the tank being

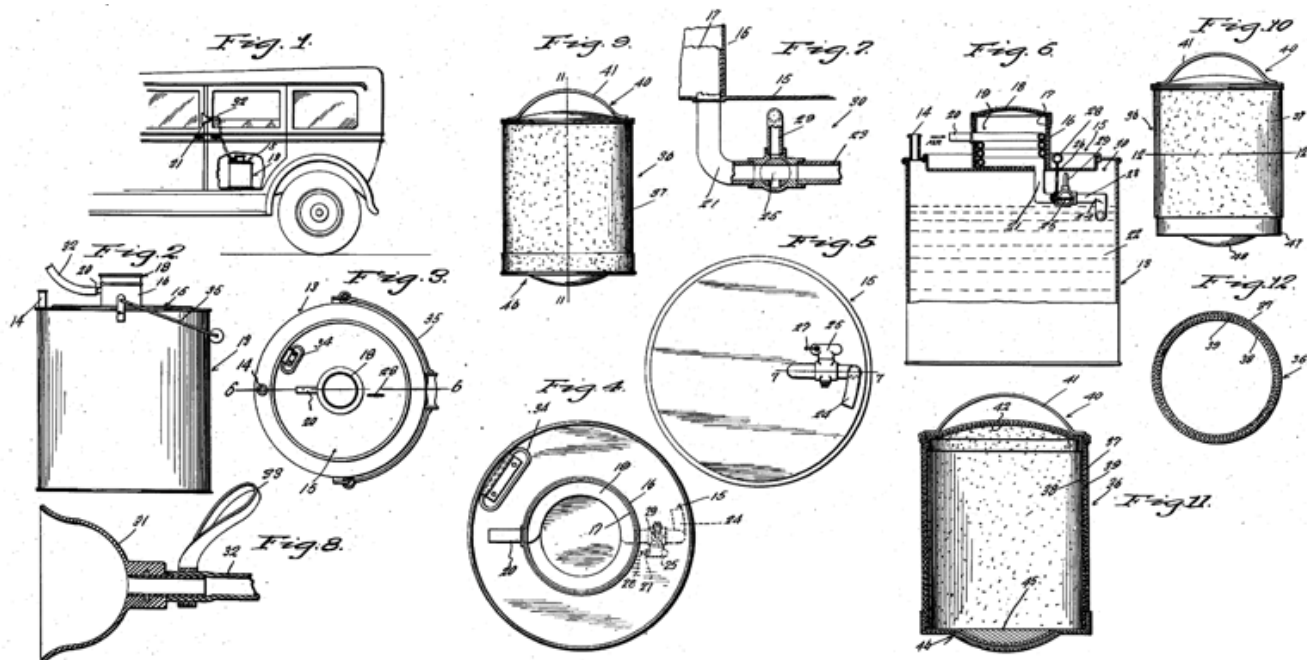

Figure 108: Albert S. Haislip's automobile aerated transporter, 1935.

placed between the audience and the actors or musicians. The inventor apparently knew nothing about the weight of water, however, since he blithely talked about the tank easily being installed on stage and taken up when the performance was over. Furthermore the design was inherently unstable so I, for one, would not like to have been standing anywhere near it.

Figure 1 represents a perspective view of the illusion apparatus, Figure 2 is a fragmentary section along the line 2 - 2 in Figure 1, Figure 3 is a similar section showing a modified construction of the tank included in the apparatus, Figure 4 is a transverse section taken on the line 1 - 1 Figure 2 drawn to a larger scale, and Figure 5 is a section similar to Figure 4 showing another modification in the construction of the tank.

In the use of the illusion apparatus as shown in the drawings, the audience saw the body of water and through it the actors who could enter the chamber or space behind the tank while the stage was dark or by means of a slide or other contrivance, which not being an essential part of the invention, was not shown in the drawings. The illusion was heightened by dressing the actors in appropriate costumes to represent fishes, divers or mermaids, and by the use of properly directed lamps the entire scene could be

illuminated so as to enhance its artistic and mystifying effect upon the audience. If the tank was sufficiently large, the chamber or space behind it could contain a piano and other instruments and a number or musicians could be gathered there to produce orchestral choral music. The sound of the music was propagated to the audience through the space 13 and could be clearly heard which increased the delusion. While the invention was more particularly designed for stage illusion, it could be adapted for house use as a tank for goldfish etc. In this case the chamber, which in the illusion apparatus was occupied by the performers, could contain plants that would show through the front of the tank and thereby create the effect that they were growing under water.

[Figure 110, *Fish Race Apparatus*, Number 2117616] Another screwball invention was that assigned to Irving I. Levenstein of Brooklyn in 1938. It consisted of a number of horizontal glass tubes or raceways into which were placed the piscatorial contestants (Levenstein suggested goldfish or "...other small species..."). A pump was situated in the bottom of the contraption and conveyed water through the raceways towards the starting point to stimulate the fish to swim. The inventor suggested that the flow of water could be increased to drive the fish back to their starting gates after the race was over.

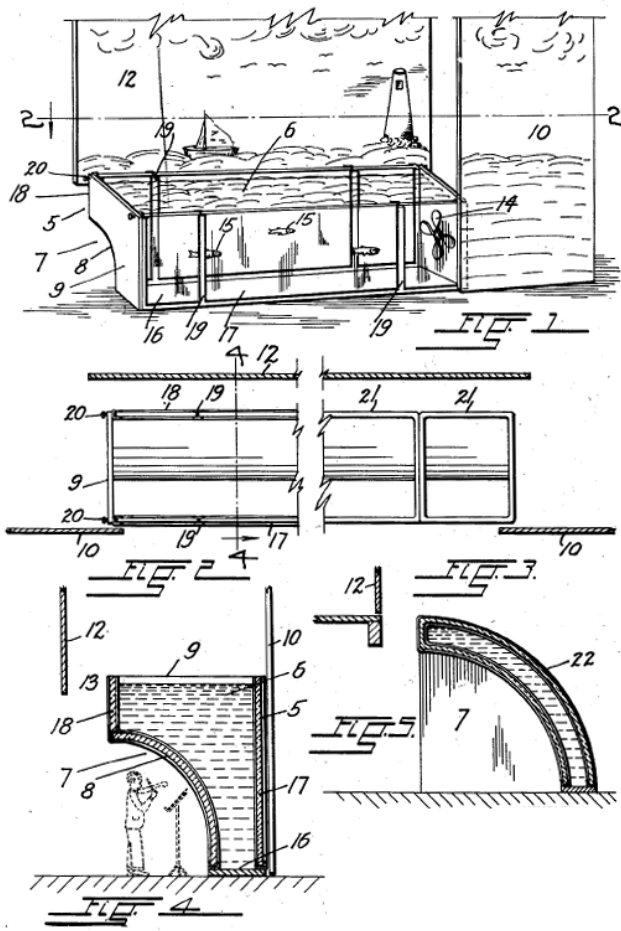

Figure 109: Elmer E. Schlotz's illusion apparatus, 1930.

The handle opened up all the starting chambers simultaneously, a detail of the chambers being shown at the bottom of the drawing.

Fig. 1 is an elevation, partly in section of a device embodying the invention; Fig. 2 is a side view, Fig. 3 is a section taken at line 3 - 3 in Fig. 2, Fig. 4 is a perspective view of a fish receptacle used at the start and goal and Fig. 5 shows in perspective, a slightly modified form of an end for a raceway.

The numeral 15 indicated elongated substantially horizontal glass tubes or other structures to serve as troughs for water raceways. Ends 16 and 17, of each of these raceways opened at the top to receive the wire mesh receptacles 18, were connected by piping 19 in which was interposed the pump 20 driven by a motor 21. The receptacles 18 were each provided with a vertically slidable gate 22, which when lifted,

permitted free passage of a fish from the receptacle 18 into the raceway 15 or vice versa.

Each of the entries, as for instance goldfish or other small species, were placed in individual receptacles 18 at ends 16 of the raceways. The pump was operated to agitate the water, whereby a current was produced in the raceways to emulate the movement of natural streams in a direction flowing towards the starting points, namely, the ends 16. The owner of each fish, upon a given signal, lifted the gate of the receptacle 18 holding his entry, whereupon the fish were free to enter the respective raceways. Relying upon the habits of fish they will swim, or at least the current against them will tend to make them swim, towards the opposite ends of the raceway. The fish that first passed into the receptacle 18 at the other end would be the winner.

The fish at the end of the race could be allowed to enter the receptacles 18 at the goals 17 or else the pump

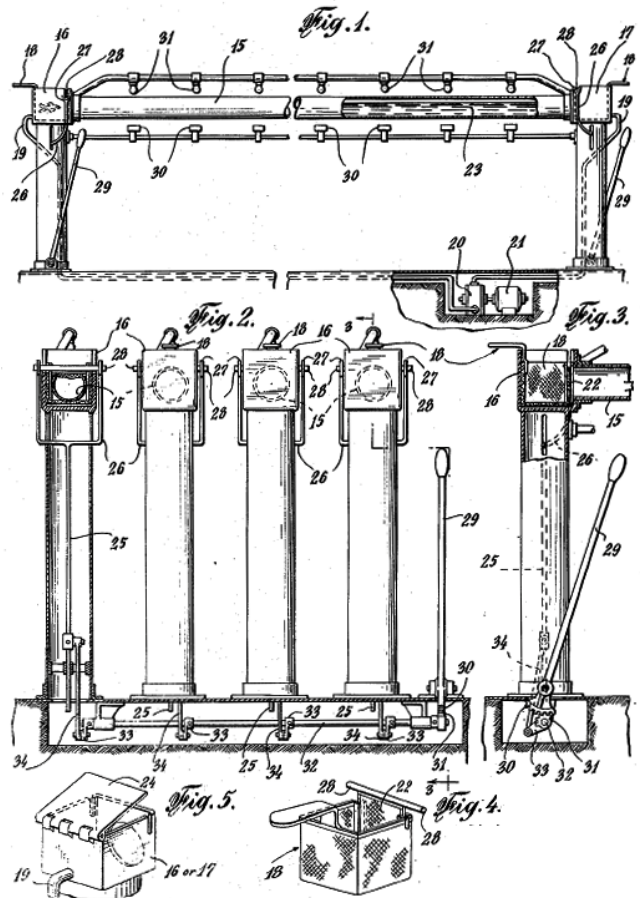

Figure 110: Irving I. Levenstein's fish race track, 1938.

could be speeded up to such an extent that the current would force all the fish back to the receptacle 18. In which event, ends 17 could be covered by lids 24 or the direction of rotation of the pump could be reversed and speeded up so that all losers would be forced into the receptacles at their respective goals.

It was useful to include a mechanism whereby all the gates could be lifted simultaneously. For such purpose, at the ends 16 and 17 of each raceway 16 for each unit there was provided a vertically slidably mounted rod 26, terminating in a yoke 26, the arms of which embraced the raceway ends. Upon upward movement of the rod 25 the gates would be lifted, and upon downward movement of such rods 26 the gates would fall due to their weight. Lever 29, when moved, would cause segmental gear 30 to turn its co-acting segmental gear 31 on stud shaft 32 which carried the crank 33 linked by member 34 to the rod 25. Movement of the lever 29 in one direction would cause all the gates to lift up simultaneously, and upon reverse movement of the lever all the gates would fall due to gravity.

To urge the fish toward their goals, bait could be moved in the raceways towards the goals at a speed faster than the fish could swim. To indicate the progress of the race, photoelectric cells 30 could be employed with co-operative light sources 31 in suitable

circuits, including a bank of lamps on an indicator board.

[Figure 111, *Attachment for Aquarium Tanks, Number 1943417*] One of the really odd tank designs of this period took its inspiration from the arched birdcage aquarium patented in 1877 by Matthew Palen and Daniel Sexton. This was conceived in 1934 by George W. Bringman of Cleveland, but the arch in this case was submerged in the aquarium after first loosening a valve near its top to permit the water to enter. After fully filled with water, the valve was closed and the arch was then raised and placed on two crossbars. The fish could then swim from the main tank through the arch and back again.

Figure 1 is a plan view of the invention attached to an aquarium for use with either quiet water or continuous flow of water, Fig. 2 is a side elevation of the aquarium with the arch elevated and filled with water, Fig. 3 is an end elevation of Fig. 2, Fig. 4 is an enlarged longitudinal section of the arch and adjusting bracket and upper part of the aquarium taken on line 4 - 4 of Fig. 1, Fig. 5 is a fragmentary plan view of part of the arch and adjusting brackets, Fig. 6 is an end elevation of the arch and adjusting brackets taken on line 6 - 6 of Fig. 4, Fig. 7 is an enlarged sectional view on line 7 - 7 of Fig. 6 showing the first position with the knob valve open and the air flow-

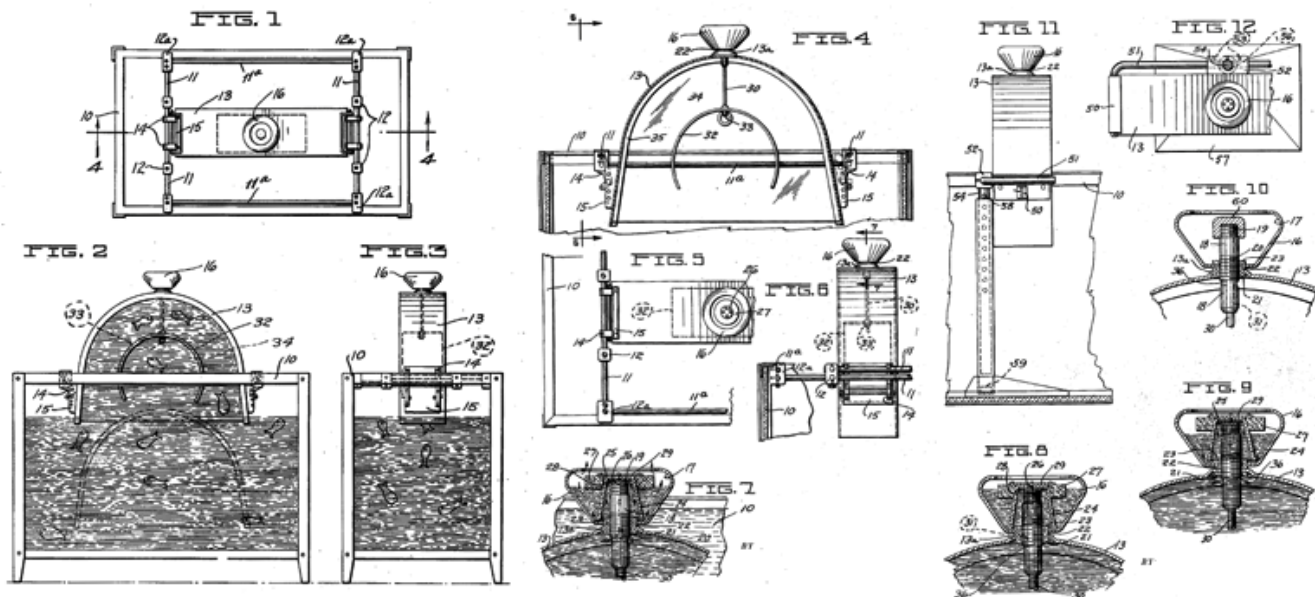

Figure 111: George W. Bringman's arch aquarium, 1934.

ing out the top drawing the water into the knob through valve by suction, Fig. 8 is a section similar to Fig. 7 but in the second position with the knob valve closed and the water at the high level, Fig. 9 is similar to Figs. 7 and 8 but in the third position with the knob valve open and the water receding into the aquarium, Fig. 10 is a section similar to Figs. 7, 8 and 9, but with a screw cap replacing the valve, Fig. 11 is a fragmentary end view of an aquarium with a modified device for quiet flow of water and Fig. 12 is a fragmentary plan view of Fig. 11.

In operation the valve 24 was placed over the top 5 of tube 18, and the arch 13 was slowly lowered into the tank which caused the air inside the arch 13 to escape through the hollow knob 16 as shown in Fig. 7. Water from the tank then pressed in through the apertures 36 in the tube 18 and into tube. The water, following the air through the clearance between the top of tube 18 and the valve 24, fell downward within the valve and escaped into the hollow knob 16. The water rising caused the float to move upward and when the arch was raised the float would lower and close the valve and stop the flow within the knob as shown in Fig. 8.

The arch was raised until the rods 11 were engaged by the lugs or hangers 14 to support the arch in raised position. The valve 24 should not be disturbed after the arch 13 was once filled unless it was necessary to drain the arch when the valve 24 was raised and the water retreated through the valve and back through the bore 31 in tube 18 and out through aper-

tures 36 in the lower part of tube 18 and down into the tank. Water could be added by pouring it into the knob 16 or by placing a hose or pipe line within the knob.

When the arch 13 was being lowered into the water the valve 24 rose just enough to allow the air to escape and fill the arch with water. When full and the arch had been raised so that the top of the tube 18 was at or above the level of the water in the aquarium, the resilient washer within the valve 24 pressed on the top of tube 18 and closed the valve. When fresh water was added, the float rising caused the valve to open and a portion of water entered the arch 13. The knob draining caused the float to drop and again closed the connection until the water again rose in knob 16. If only quiet water was used a modified form could be used in which brackets 50 (Fig. 11) were attached at each side of arch 13 through which bent arms 51 were mounted and held within each end of block 52 by set screws 53. A shaft 54 extended upwardly through block 52 with a plurality of apertures 55 through the shaft at intervals.

Shaft 54 was raised or lowered within a hollow glass tube 56 mounted upon base 57, the shaft 54 being retained at any desired height by a pin 58 being thrust through any of the apertures 55, the pin 58 resting across the top of glass tube 56. A resilient plug 59 was inserted in the base of the glass tube for drainage purposes. In the form shown in Fig. 10 a cap 60 was screwed on the tube 18 instead of the valve, and could be removed to let in air to empty the arch.

[Figure 112, *Water Passover*, Number 2059927] A fish bridge design created to unite two separate aquariums was patented by Oscar G. Beck of Herrick, Illinois in 1935.

Figure 1 is a fragmentary vertical sectional view, Figure 2 is a sectional view on the line 2 - 2 of Figure 1, Figure 3 is a sectional view on the line 3 - 3 of Figure 1, Figure 4 is an end elevation, Figure 5 is a perspective view of a closure member for each open end of the device, Figure 6 is a side elevation of the device in reversed position from that shown in Fig-

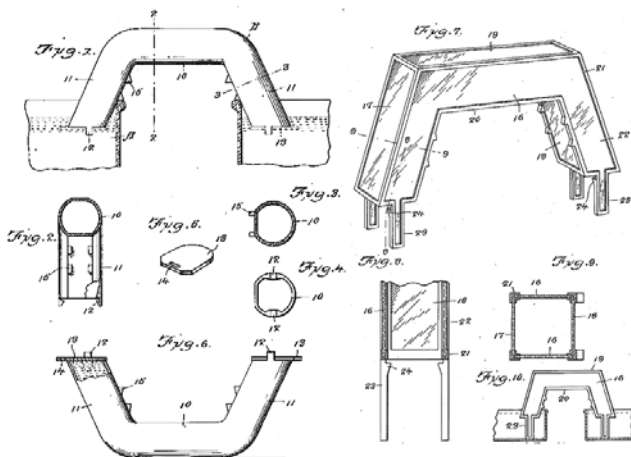

Figure 112:
Oscar G. Beck's fish bridge, 1935.

ure 1 and partly in section, Figure 7 is a perspective view of a modified form of the device, Figure 8 is a sectional view on the line 8 - 8 of Figure 7, Figure 9 is a sectional view on the line 9 - 9 of Figure 7 and Figure 10 is a view similar to Figure 1 showing the modified form of the device in association with adjacent aquariums, tanks, pools or containers.

To have the device operate it was necessary to have the body 10 inverted from the position shown in Figure 1 of the drawings to the position shown in Figure 6 and in this position water was introduced into the body 10 to fill it. Thereafter the gates 13 were placed in position to engage the lugs 12 so as to close the open ends of the body for retaining the filled condition of the device whereupon the filled device was turned on itself and placed as shown in Figure 1 with the shoulders 15 resting upon the edges of the open tops of the aquariums, tanks, containers or the like A,

then by a suitable implement engaged in the slots 14 and the gates 13 these could be removed from the ends of the body 10 and thus the filled condition of the device constituted a water passover or swimway between the aquariums, tanks, containers or the like.

In Figures 7 to 10 of the drawings there was shown a modification wherein the device was constituted by transparent side panels 18, outside and inside end panels 17 and 18, respectively, and outer and inner top panels 19 and 20, respectively. These panels were fitted with a frame 21, the panels being sealed at their edges next to the frame. This frame had open ends at the leg portions 22 which were provided with the extensions 23 forming props. The extensions carried keepers 24 for the gates.

[Figure 113, *Combination Aquarium, Number 2000451*] We'll begin our discussion of aquarium designs in this decade with combination configurations, starting with the one by Adolf W. Krieger of Brooklyn in 1935. This included an aquarium, a bird cage, and several, plant containers.

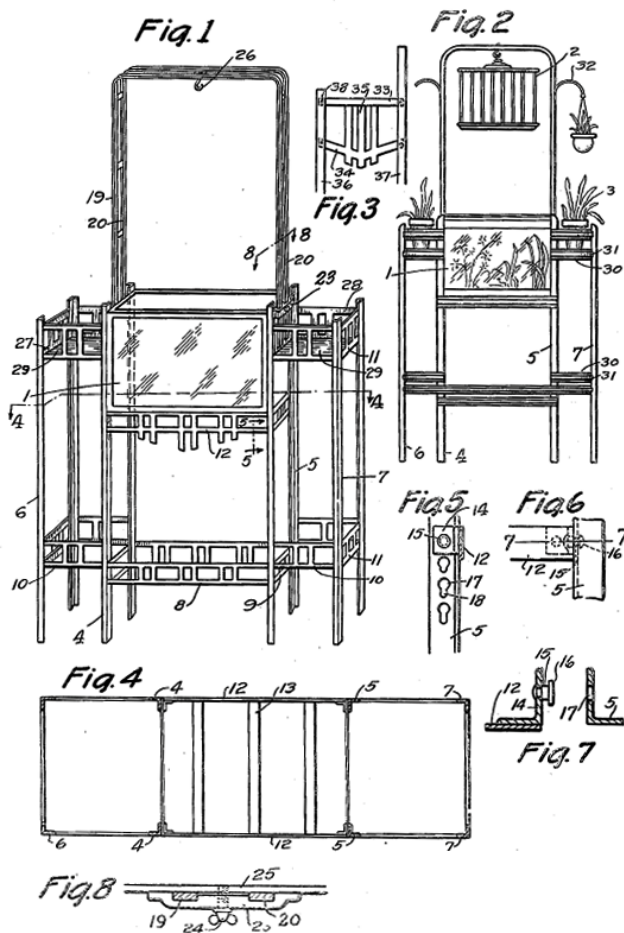

Figure 1 is a view showing one arrangement of the aquarium stand, Figure 2 is a view showing a stand of a different design, Figure 3 is a detail showing an end view of the stand in which the rear portion of the stand extends upward above the front portion, Figure 4 is a sectional view taken on the plane defined by the line 4 - 4 on Fig. 1 the aquarium being omitted, Figure 5 is a sectional view taken on the plane defined by the line 5 - 5 on Fig. 1, Figure 6 is a detail looking toward the front of the section shown in Figure 5, Figure 7 is a sectional view taken on the plane defined by the line 7 - 7 on Fig. 6 and Fig. 8 is a sectional view taken on a plane defined by the line 8 - 8 on Fig. 1. Although this is a utility patent, the figures are sufficient to describe the design.

[Figure 114, *Combined Aquarium and Flower Stand, Number D109478*] The creation of Robert Furrey of Council Bluffs, Iowa in 1938 was another that combined an aquarium with plant containers. However, "less is more" is not the basis for these two rather intricate designs!

Figure 113: Adolf W. Krieger's combination aquarium and plant stand, 1935.

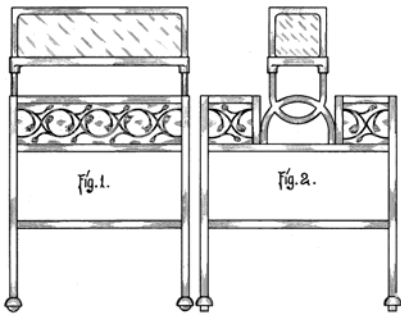

Figure 114: Robert Furrey's combination aquarium and plant stand, 1938.

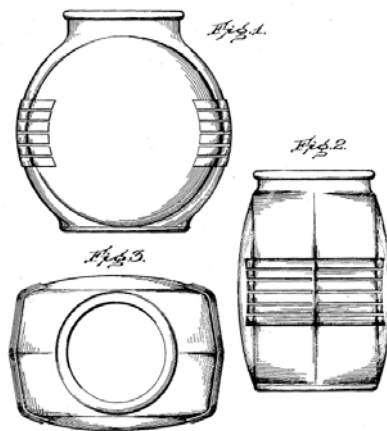

Figure 115: Michael S. Desser's flat fish bowl design, 1935.

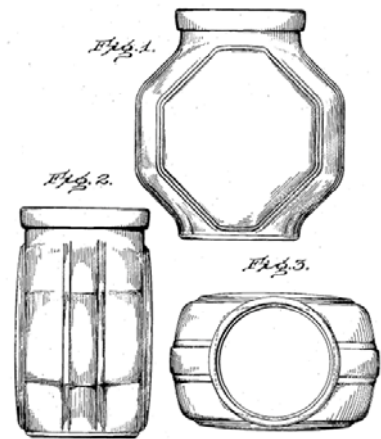

Figure 116: Edwin W. Fuerst's flat fish bowl design, 1936.

Figure 117: Arthur von Frankenberg's fish globe design, 1936.

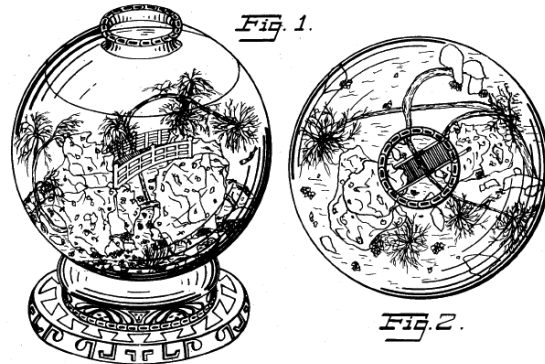
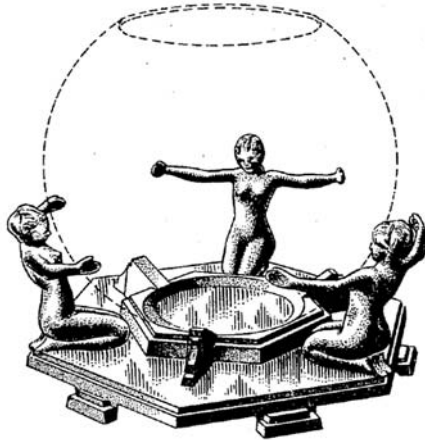

Figure 118: Mitsuo Matsuno's fish globe design, 1931.

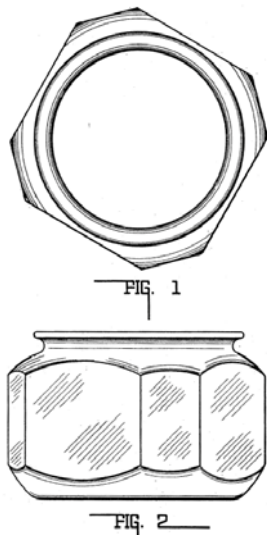

Figure 119: David A. Jenkins's fish globe design, 1933.

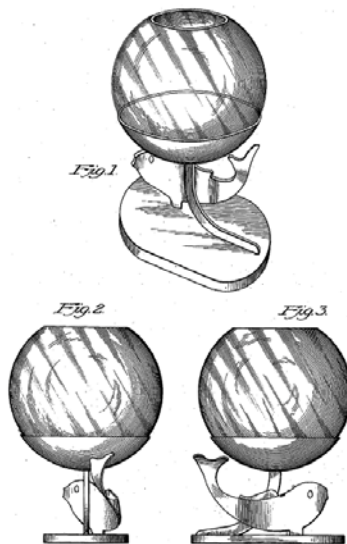

Figure 120: Lester K. Franklin's fish globe Design, 1936.

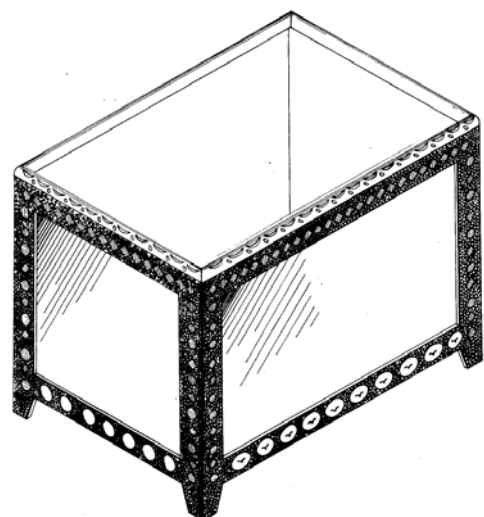

Figure 121: Hermann Hufner's rectangular design, 1931.

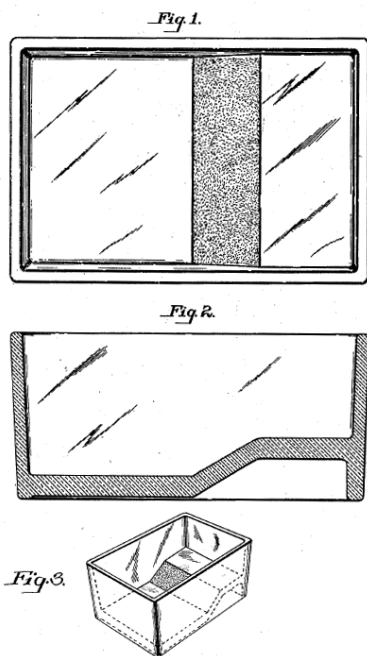

Figure 122:
Thomas W. McCreary's all-glass
shelf tank, 1932.

[Figure 115, *Fish Jar*, Number D97041] Flat fish bowl designs in this decade were advanced by Michael S. Desser of Toledo, Ohio in 1935 (*Fish Jar*, Number D97041).

[Figure 116, *Fish Jar*, Number D102550] Desser designed another with his co-inventor, Edwin W. Fuerst in 1936. Both are very nice artistic variations of the plain, flat-sided fish bowl.

[Figure 117, *Design for an Aquarium or Similar Article*, Number D80204] Globe designs abounded, including one by Arthur von Frankenberg of New York City in 1929.

[Figure 118, *Design for an Aquarium or Similar Article*, Number D85253] A second was that in 1931 of Mitsuo Matsuno also of New York City (*Design for an Aquarium or Similar Article*, Number D85253).

[Figure 119, *Bowl*, Number D89307] A third was that of David A. Jenkins of Kokomo, Indiana in 1933.

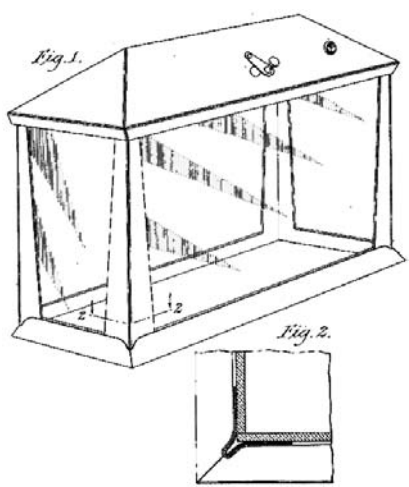

Figure 123: John J.
Halterbeck's tapered frame
aquarium, 1932.

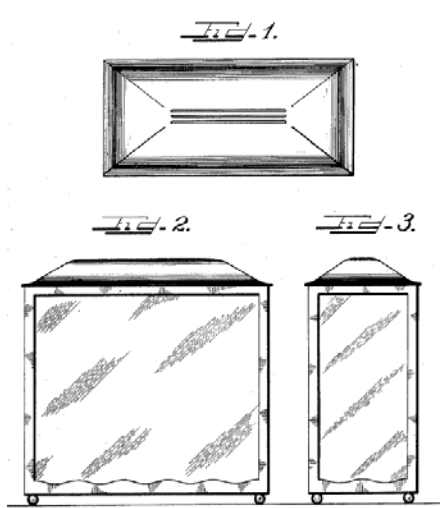

Figure 124: Arthur P.
Swanson's tall tank with a
scalloped design, 1934.

[Figure 120, *Combined Fish Bowl and Stand*, Number D98718] A fourth was that by Lester K. Franklin of Chicago in 1936.

[Figure 121, *Aquarium*, Number D85181] Rectangular designs were represented by those of Hermann Hufner of New York City in 1931 and the following three:

[Figure 122, *Aquarium Bowl*, Number D86325] This one was by Thomas W. McCreary of Monaca, Pennsylvania in 1932. Unfortunately, since like the others this was a design patent, McCreary did not explain the purpose served by the shelf in his design;

[Figure 123, *Design for an Aquarium*, Number D86914] This one was by John J. Halterbeck of Long Island City, New York in 1932.

[Figure 124, *Design for an Aquarium*, Number D93365] This one was by Arthur P. Swanson of Maine Township, Illinois in 1934.

[Figure 125, *Aquarium*, Number 1965323] One very modern looking fountain aquarium was patented during this decade, that by Nathan Taslitt of Hartford, Connecticut in 1934.

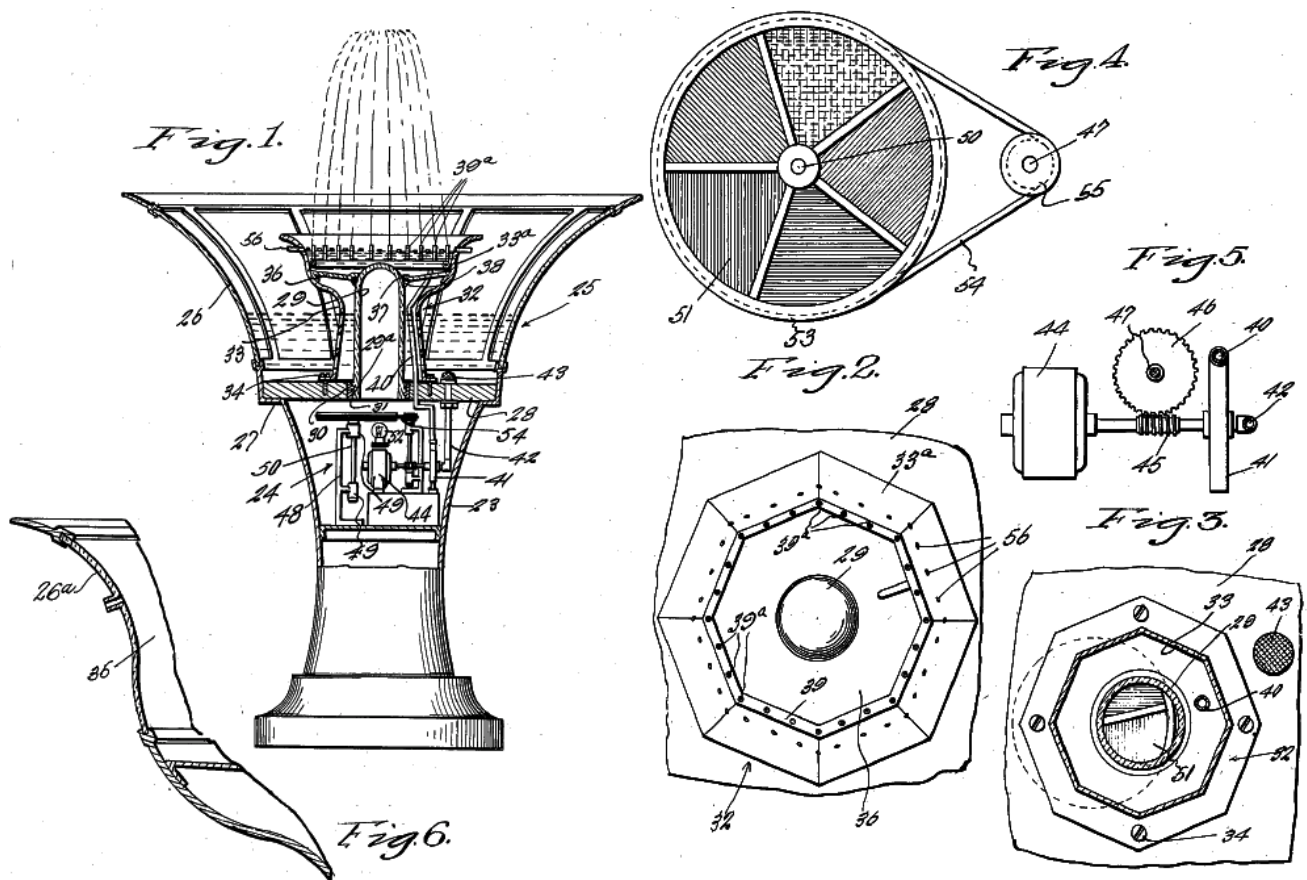

Figure 125: Nathan Taslitt's fountain aquarium, 1934.

Figure 1 is a view partly in section and partly in elevation, of a combined aquarium and fountain embodying the features of the invention, Figure 2 is a top plan view showing the arrangement of the spray head of the fountain, Figure 3 is a sectional elevational view illustrating certain features and details of construction, Figure 4 is a plan view of a color changing disk and a portion of the drive means therefor, Figure 5 is a detail plan view certain parts being shown in section illustrating the manner of driving a pump and the color disk from an electric motor, and Figure 6 is a fragmentary sectional elevational view of a slightly modified form of cup forming part of the combined fountain and aquarium structure.

Water to a suitable level was contained within the bowl 25 and through the medium of the motor driven pump a continuous circulation was provided whereby the water was drawn from the bowl and forced upwardly to discharge in the form of a spray from the spray head as shown in Figure 1. The falling spray played on the water contained in the receptacle

part 33a of the bowl to a suitable depth. The upper end of the spray emitting tubes 39a terminated above the level of the water in the receptacle part 33a, such part being provided on its rim or wall with a circular series of relatively spaced tubes 56 whereby provision was made for maintaining the water in the receptacle part 33a at a predetermined level. During the operation just described the change-color disk 51 would be rotated at a suitable speed for bringing the different color segments opposite to the lamp 52, enhancing the attractiveness of the fountain.

Regardless of the depth of the water in the bowl, the colored light rays were projected to the top of the spray. Furthermore, by keeping the water level in the receptacle 33 a little above the top of the globe 29, the colored light rays were reflected through the open work design or grill of the member 32 on to the water flowing from the tube 56 and also on to the surface of the water in the bowl. The fountain could also serve in the nature of an aquarium, the fish being placed in the bowl.

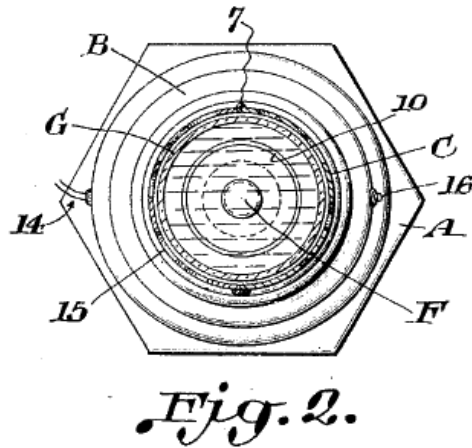
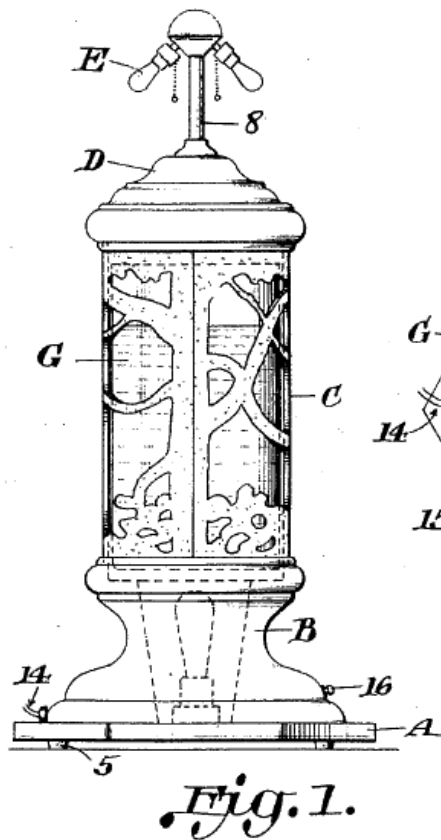

Fig. 2.

Figure 126:
Charles Emma's lamp
aquarium, 1929.

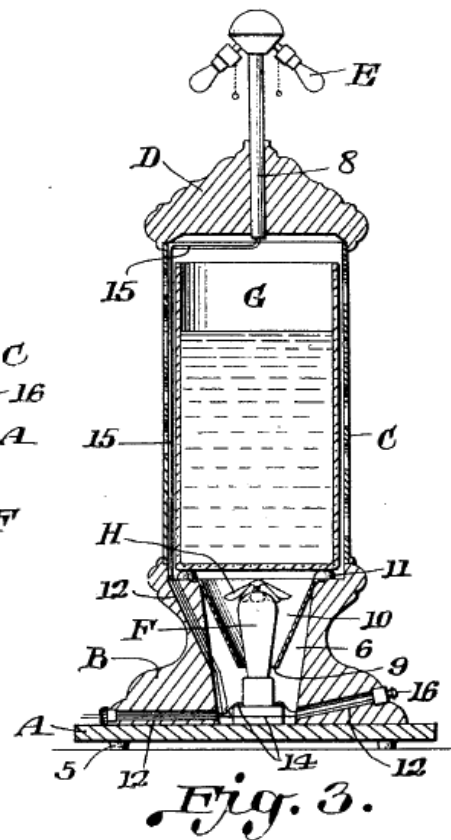

Fig. 3.

[Figure 126, *Illuminated Aquarium Lamp, Number 1723272*] There were, however, a number of lamp aquariums patented, starting with that of Charles Emma of Philadelphia in 1929. Figure 1 is an elevation of the device, Figure 2 is a horizontal section and Figure 3 is a vertical section.

A base **A** was provided with felt or rubber pads **5** supporting a body portion **B** of suitable decorative contour having an enlarged central cavity **6** and supporting a decorative casing **C** made in sections and hinged at **7** for an opening to provide access to the interior. An appropriately decorated cap **D** rested on the decorative casing and served to support a tubular standard **8** for a light cluster **E** that could or could not be used at the time the main illuminating device was in operation. A lamp **F** mounted in the central cavity of the base projected through an opening **9** in a frusto-conical mirrored reflector **10** mounted to throw the beams from the light upwardly within the casing. A glass globe **G** of suitable cross section was mounted within the casing on felt or rubber pads **11** so that it was spaced from the base, and could be filled with water serving as an aquarium or for a re-

ceptacle within which a fountain (not shown) could be made to play and direct its waters down the interior walls.

A vaned and multicolored shield **H** could be mounted on the tip of the lamp so that the heat from the lamp revolving the vane the light would be shown of a different color passing upward to the aquarium. The base **B** could be suitably apertured as at **12** for the accommodation of the light circuit wires **14** from which a lead **15** could carry the current upwardly within the casing and through the standard **8** to the light cluster. A suitable switch **10** could be supplied and conveniently mounted in the base as shown.

Rays from the lamp would be directed upwardly so that the water in the globe would be lighted throughout illuminating objects, such as fishes, swimming in the water, and the light would be diffused and send a glow through the decorated casing. While a design of trees and shrubbery was conventionally shown as a filigree or cutout decoration for the casing, any other suitable design could be used, the parts thereof serving to protect the glass globe from any casual injury.

[**Figure 127, Fish Bowl and Lamp Combination, Number 1762634**] The second lamp aquarium patent was by Motogo Jyumi of Oakland, California in 1930. An innovative feature of Jyumi's design was the positioning of air tubes within the bowl to insure a convection circulation of air within the bowl.

Figure 1 is a side view showing a combination fish bowl and lamp unit embodying the invention, a portion of the structure being shown in sectional elevation; Figure 2 is an enlarged fragmentary sectional view taken on the line 2 - 2 in Figure 1 and Figure 3 is an enlarged plan view of a lamp base of the structure as viewed on the line 3 - 3 in Figure 1.

Extending axially upwardly from the member 7 was a threaded boss 13 providing a mounting for a suitable source of illumination. As shown, an electric lamp socket 14 was mounted on the boss 13, the socket containing a lamp 15 placed in an upright position. The member 7 functioned as a supporting

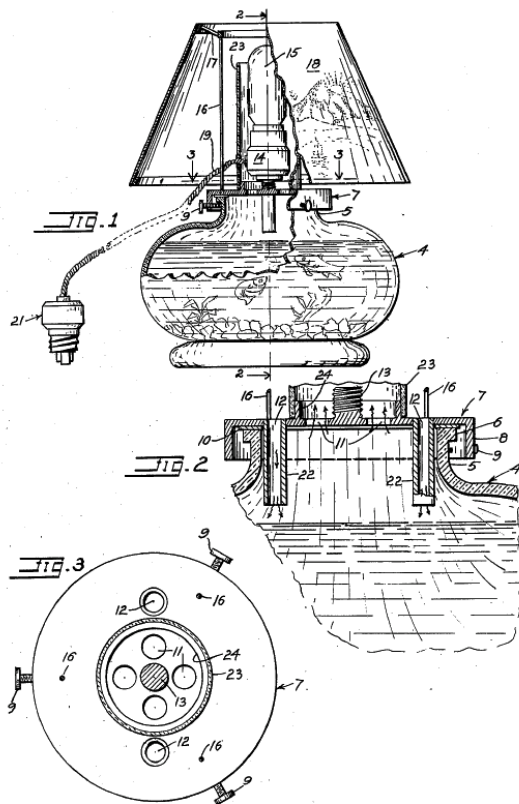

Figure 127:
Motogo Jyumi's lamp aquarium, 1930.

base for the lamp. Also extending upwardly from the member 7 were rods 16, the rods supporting a lamp shade frame 17 on which was mounted a shade 18 of suitable size and design. The necessary wires 19 for supplying current to the lamp 15 were directed through the side of the socket 14 and were provided at their free end with a suitable attachment plug 21.

When the lamp 15 was unlit, the air circulation through the openings 11 and 12 of the closure member 7 was generally sufficient to provide the necessary supply of fresh air to the bowl 4. To insure a maximum movement of circulated air in the bowl under these conditions, tubes 22 were mounted on the member 7 that extended downwardly from the outer set of openings 12 toward the surface of the water in the bowl. In this manner, warmer air rising to and escaping through the inner set of openings 11 would cause an inward flow of fresh air through the tubes 22 for discharge near the water surface, thus insuring some circulation of fresh air at and along the water surface at all times whereby the fish could obtain air by rising to the surface as they must do in quiet waters generally.

When the lamp 15 was lit, some of the heat generated thereby would be radiated, both directly and by reflection from within the shade 18 toward the bowl and its contents, and the resulting heating thus produced could proceed faster than the cooling by the convection circulation previously described even though the latter increased its quantity flow rate on account of the radiated heat. Accordingly, it was highly desirable that the effect of the radiated heat be overcome in a positive manner. Thus, the desired result was obtained by suitably increasing the convection circulation through the bowl by utilizing the heat of the lamp, the lamp functioning essentially as a heat source for this specific purpose. In this manner, the exposed water surface was constantly cooled by evaporation induced by the circulated air.

To utilize to the fullest extent the heat of the lamp for producing the desired increased convection circulation of air through the bowl, placed about the lamp in upright position was a tubular chimney member 23 whereby a definite up-draft was created along the

lamp and through the openings 11, the latter openings lying within the base of the member 23. The chimney member 23 was formed of a transparent or at least translucent material that could be a heat resistant glass, mica or other suitable composition. As shown, the base member was provided with an upwardly extending annular flange 24 for engagement with the base of the member 23 to hold the latter in a coaxial relation to the lamp 15. The wires 19 were led from the space within the member 23 through a suitable perforation therein.

[Figure 128, *Aquarium, Number 1871742*] Albert Sabath of Chicago patented his lamp design in 1931. Sabath's design was especially interesting in that a lamp and a fan were situated within the clear glass chimney that supported the fish bowl. Within the chimney was a cylindrical screen that rotated as the warmed air rose. The screen could be painted with any aquarium subject, fish being pictured in the

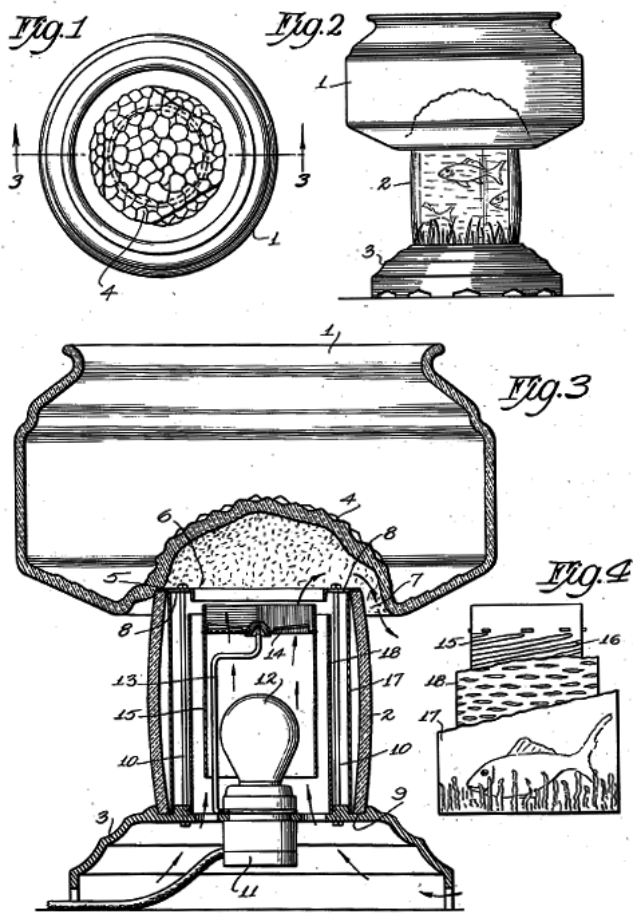

Figure 128:
Albert Sabath's lamp aquarium, 1931.

drawing. A colored lamp could also provide additional pictorial interest.

Figure 1 is a top plan of the device, Figure 2 is a side elevation, Figure 3 is an enlarged vertical section, taken on the line 3 - 3 of Fig. 1 and Figure 4 is a side elevation, partly broken away, showing the two screens and the picture panel.

In operation, the rising heated air passing through the fan 14 rotate the cylindrical screen 15 for producing the desired motion effects on the pictorial representations and for simultaneously producing color effects within the aquarium. With this construction, a large number of different scenic and color effects could be produced. If desired, instead of using the artificial illuminating mechanism below the aquarium, the dome 4 could be coated with a luminous paint.

[Figure 129, *Combined Lamp and Fish Bowl, Number D108779*] Two lamp aquarium designs by Herbert F. Crewse of Des Moines, Iowa appeared in 1938. The aquarium in Crewse's first patent featured an unusual, pear-shaped globe. Slots were cut into the globe to provide air and I suppose to feed the fish (as this was a design patent, Crewse does not

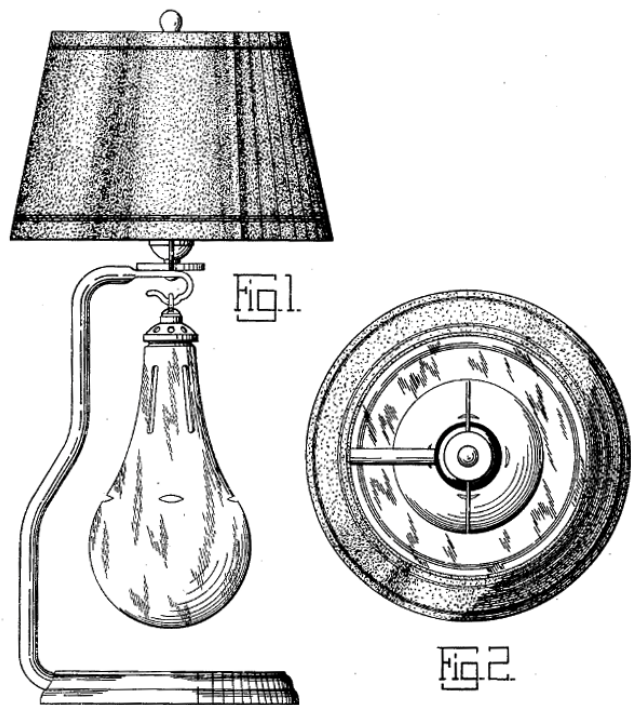

Figure 129:
Herbert F. Crewse's lamp aquarium, 1938.

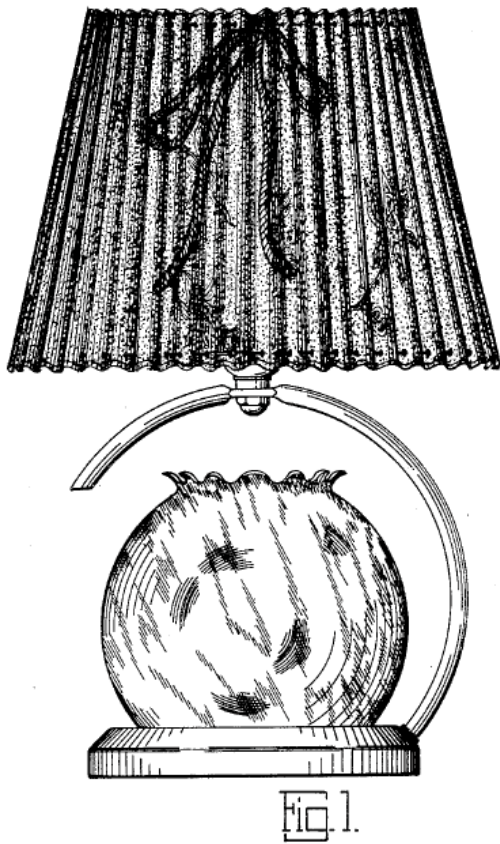
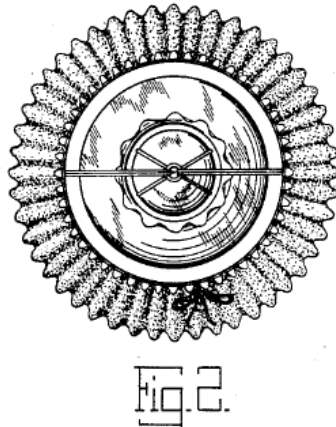

Figure 130:
Herbert F. Crewse's
second lamp
aquarium, 1938.



elaborate), but this was a very awkward and impractical design.

[Figure 130, *Combined Lamp and Fish Bowl*, Number D110271] This was Crewse's second patent.

[Figure 131, *Combined Aquarium and Picture*, Number 1777944] Four wall aquarium patents were awarded during this decade, the first by Charles Trovato of Corona, New York in 1930. His design was interesting, being half-picture and half aquarium (the lower half).

Figure 1 is a front elevation of the aquarium constructed in accordance with the invention, Figure 2 is an end

elevation, Figure 3 is a rear elevation, Figure 4 is a sectional view taken approximately on the line 4 - 4 of Figure 1 looking in the direction of the arrows, Figure 5 is a sectional view on the line 5 of Figure 1, Figure 6 is a sectional view on the line 6 - 6 of Figure 1, Figure 7 is a sectional view on the line 7 - 7 of Figure 1, Figure 8 is a fragmentary perspective view of the fish container detached from the aquarium and Figure 9 is a fragmentary horizontal sectional view through the aquarium showing a modified form of fish container.

The aquarium comprised a picture frame **10** that could be ornamented in any desirable manner, and to this frame at its back was secured a box-like body **11**, which constituted a backing for the frame. The body **11** was tapered from top to bottom so that the lower portion gradually narrowed to the bottom of the frame. This body in its side walls at the upper half thereof was provided with ventilating orifices or holes **12**, while the frame center was entirely open which also increased ventilation. Located within the body **11** in the lower portion was a fish container or well **13**, which was cor-

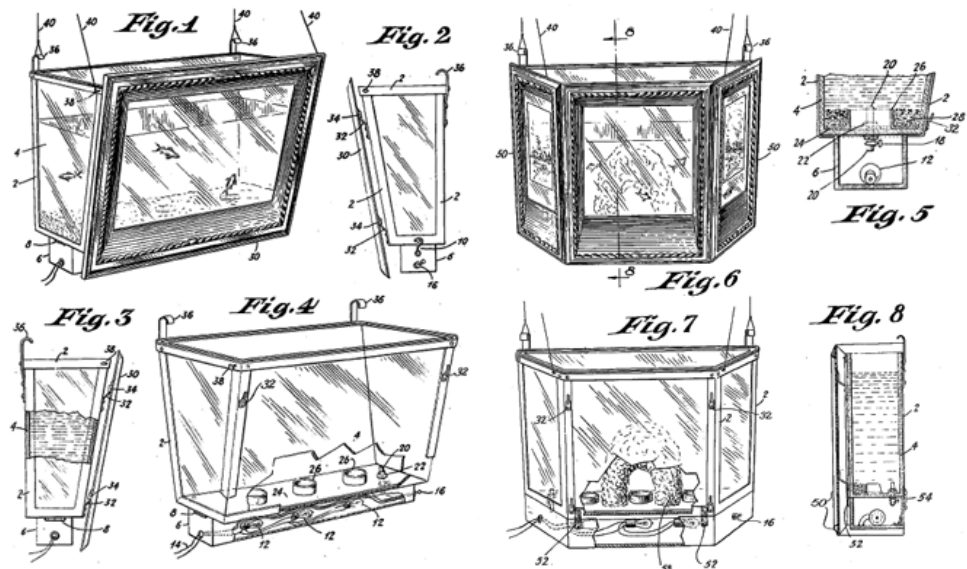

Figure 131: Charles Trovato's wall aquarium, 1930.

respondingly shaped to the lower portion and adapted to hold water, the latter being let into the same through the feed lead 14 and the water discharged through an overflow or drain-off 15. The lead 14 and the overflow or drain-off could be of any desirable construction suitable to the aquarium.

The container or well 13 was in the form of a metal body having an open front 16 closed by a glass panel 17, which was secured in a manner to render the container or well liquid tight about the latter so that through this panel the fish within the container or well could be visible through the frame 10, which was adapted to be supported upon a vertical wall in any desirable fashion. On the inner face of the back 18 of the body 11 was suitably secured a scene or picture 19 that entirely covered the back above the container or well and was visible through the open center of the frame 10.

Arranged on the back of the frame 10 at its upper portion were suitable electric illuminating bulbs 20, one being preferably of blue tint and the other of yellow tint so that on illumination the rays therefrom would be thrown onto the scene or picture to give a

sunset effect thereto. The bulbs 20 were adapted to be arranged in an electric house circuit and the connections could be of any suitable type. In Figure 9 of the drawings there was shown a slight modification of the fish container or well wherein the body 21 was entirely made from glass and flanged at 22 at its ends, through which fasteners 23 passed for securing it in place.

[Figure 132, *Illuminated Wall Aquarium, Number 1974068*] Isador Greensaft of Belmar, New Jersey patented his wall aquarium in 1934. He illuminated his tanks (he pictured a number of designs) from the bottom with three lamps directly below glass-topped cylinders, and projected them a distance into the tank so as not to have the gravel block the light.

Figure 1 was a perspective view of the illuminated aquarium, Figure 2 was an end view of the apparatus of Figure 1 illustrating the manner of supporting the decorative frame to the container supporting framework, Figure 3 was another end view of the apparatus shown in Figure 1 and illustrates the manner in which the compartment was hinged to the frame-

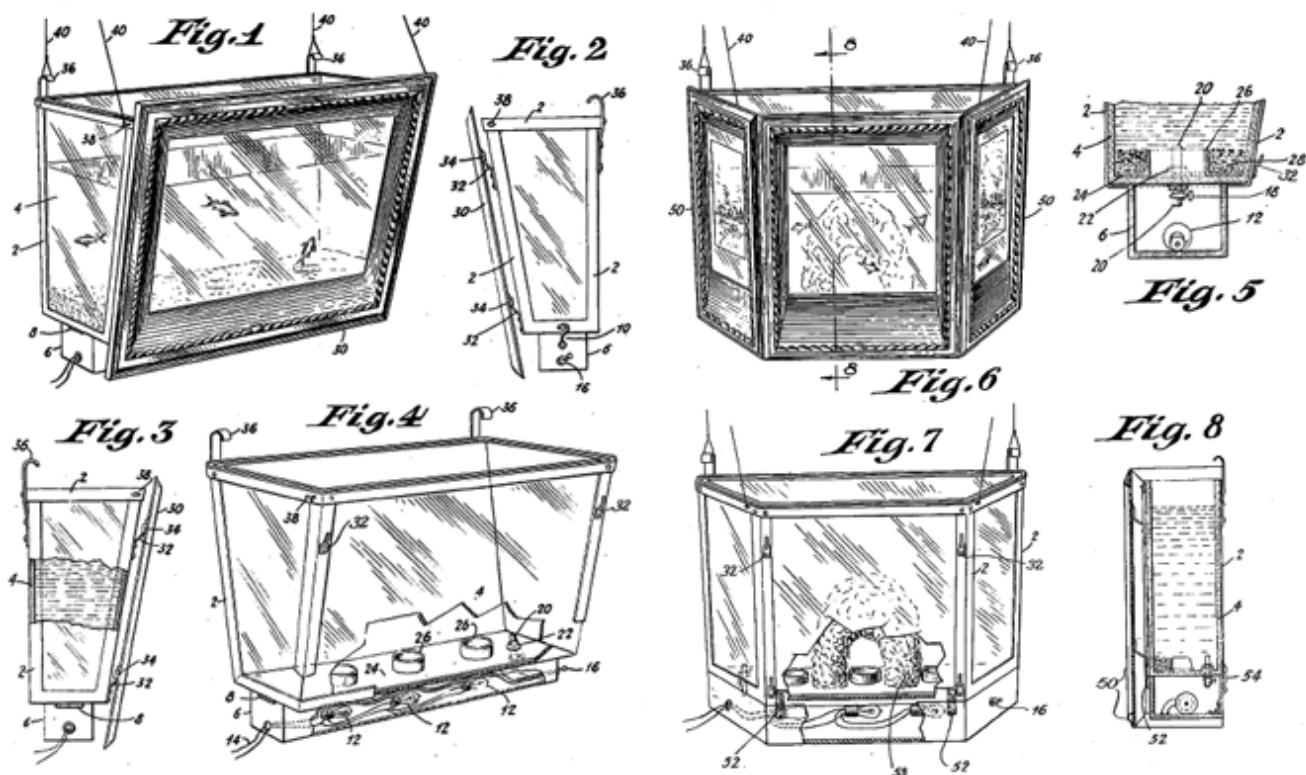

Figure 132: Isador Greensaft's wall aquariums, 1934.

work, Figure 4 was a perspective view partly in section and with the decorative frame removed, Figure 5 was a cross section of the illuminated aquarium, and Figures 6, 7 and 8 were views of a modified form of the invention, Figure 8 being a view of Figure 6 taken along the plane 8—8.

Regarding Figures 1 to 5, an open metallic framework 2 supported a transparent glass, open topped water container 4, suitably shaped so as to fit snugly within the open framework 2. The framework 2 could be of metal cast in one piece, or it could be made of several suitable pieces of angle iron and/or straps suitably fastened together as by brazing, welding, soldering or by fixing the pieces together by riveting, bolting or the like. Hinged by means of hinge 8 to the underside of the framework 2 there was a rectangular compartment or enclosure 6 of suitable material such as wood or sheet metal. The compartment or enclosure was removably fixed to the framework at its other end, as shown in Figure 2 by a latch 10 of usual form.

Within the compartment were mounted a plurality of incandescent lamps 12. Energy was fed to the lamp by a suitable line 14, and energization of the lamps was controlled by actuation of switch 16, fixed to compartment 6. The lamps could be replaced by unlatching latch 10 and dropping the compartment so that the lamps were accessible. To lessen the height of the compartment and make them less conspicuous, the lamps 12 were placed in a reclining position as illustrated. If desired, walls or separators could be placed between the lamps so that each lamp rested in a separate section of the compartment. Moreover, the lights could be colored to pass colored light through the water. To still heighten the beauty of the aquarium and make it appear as a “living” picture, a decorative frame 30 could be removably fixed to the front thereof by means of suitably spaced prongs 32 suitably fixed to the front of the framework 2 and cooperating with suitably spaced loops 34 fixed to the rear side of the decorative frame 30. The width of the frame was such that it covered the framework and compartment 6. To support the aquarium, a plurality of inwardly turned hooks 36 fixed to the rear of the framework was provided. The hooks were turned relatively forwardly so that the aquarium could rest

flush against a wall. To prevent any forward tilting, screw eyes 38 fixed to a relatively forward portion of the framework were provided. Supporting wires 40 or the like could be then fastened to the hooks and eyes and to wall supports or hooks (not shown).

In the dropped position of compartment 6 the container 4 could be drained by actuating valve or stopcock 18 so that the tank or container 4 emptied through vent or drain pipe 20. The latter was placed through a hole in the tank 4 and non-leakably fixed thereto by a suitable nut and washer arrangement 22. This nut and washer arrangement was, of course, duplicated on the underside of the tank as shown in Figures 5 and 8. If desired, a false bottom 24 could be provided having cylindrical projections 26. These projections could be surrounded with sand, stone gravel and the like 28 as shown in Figure 5. In that event, care should be taken that the vent pipe 20, projects over the surrounding sand. Also, the incandescent lamps 26 were placed directly beneath the orifices in the false bottom so that the light was projected in concentrated beams through the water, enhancing the beautifying effect of the illumination.

Referring now to Figures 6, 7 and 8 illustrating a modified form of the invention, in general the construction of this modified arrangement was similar to the form shown in Figures 1 to 5. However, to increase the artistic effect and appearance of the illuminated aquarium, it was shaped so as to have front and rear sides or faces that were parallel and sides that were not parallel to each other but arranged symmetrical with respect to the front and rear faces. The polyhedron shape to be given to the open framework was indicated in Figure 7.

The side frames 50 could be removably fixed to the open framework 2 by a suitable arrangement of prongs and metallic supporting loops as described in connection with Figures 1 to 5. If desired, translucent pictures could be painted on the side panes of the tank, and/or on the front or rear panes of the tank. The tank itself, of course, was shaped so as to correspond to the shaping of the open framework.

In the modified arrangement, the compartment was hinged by means of front hinges 52 to the framework

so that the compartment dropped away from the wall against which the aquarium rested. The compartment was held in its closed position against the tank and open framework by means of latches 54 fixed to the rear of the compartment and open framework. As an added touch of beauty an imitation stone arch 53 could be placed so as to rest on the false bottom of the tank, which in this case was also suitably shaped so as to conform to the contours of the framework.

[Figure 133, *Aquarium*, Number 1991683] Harry J. Kelly of Nashville, Tennessee in 1935 presented his version of a wall aquarium.

Figure 1 represents a side view of an aquarium constructed in accordance with and embodying the invention as seen through the front glass panel, Figure 2 represents a top plan view, Figure 3 represents an enlarged view of one of the inner or rear corners

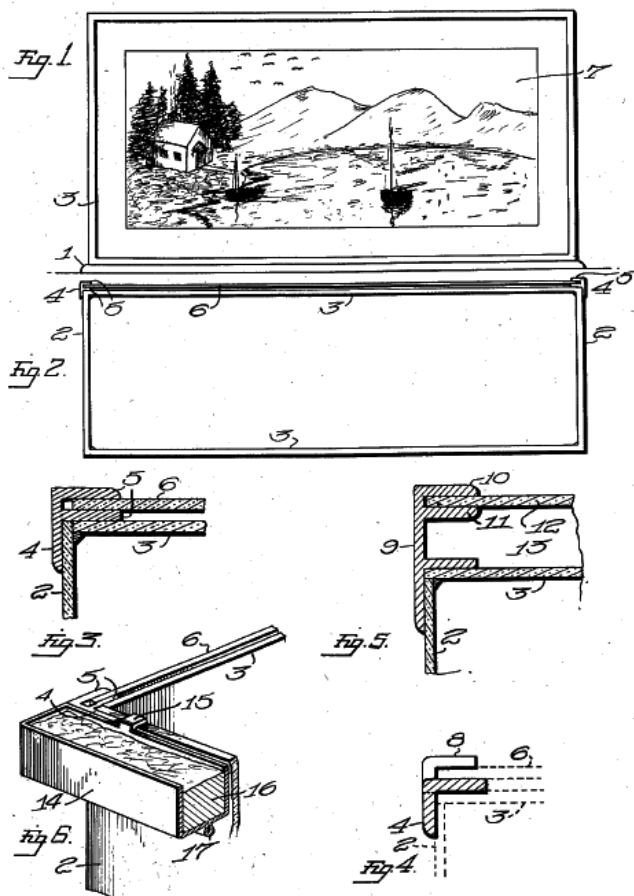

Figure 133:
Harry J. Kelly's wall aquarium, 1935.

showing the cleat to secure the picture or like article of adornment, Figure 4 shows a detail view of a modified form of corner in which the picture holding means is struck up from the metal of the corner strips, Figure 5 shows a further modified form which provides a space or chamber to receive soil in which may be planted a suitable ornamental vine or plant and Figure 6 is a detail view of another modified construction of the invention.

The aquarium consisted of the base or support 1, the end glass panels 2, the front and rear glass panels 3 and the pair of rear corner strips or angle plates 4 that were formed with cleats or guides 5, in which was fitted a panel 6 ornamented by a picture 7, or other ornamentation which showed through the front glass panel of the aquarium.

In the form of the invention shown in Figure 4, the corner angle strips were provided with struck up clips 8, which held the picture, while in the form shown in Figure 5, the corner strips were provided with a web 9, formed with ears 10, providing a cleat 11 to receive and retain a panel 12. This formed the space or chamber 13, in which could be placed dirt or water for the planting of a vine or suitable plant. The front or outer corners of the panels 2 and 3 could be made integral, or they could be secured together in any suitable manner. The form of the invention shown in Figure 6 was provided with a trough 14 and with hooks 15 for hanging it from the end or side panels. The trough was adapted to receive soil 16, for suitable plants and was further provided with a drain spout 17. This form was also provided with the corner piece 4, the cleat 5 and the ornamental panel 6, as in the other forms of the aquarium.

[Figure 134, *Wall Aquarium*, Number 2144551] Morris Skolnick of New York City in 1937 patented the last of these four.

Fig. 1 is a front view of the wall aquarium, Fig. 2 is a sectional view taken on the line 2 - 2 of Fig. 1, Fig. 3 is a sectional view taken on the line 3 - 3 of Fig. 1, Fig. 4 is an end view looking in the direction of the line 4 - 4 on Fig. 1 and Fig. 5 is a plan view of the device shown in Fig. 4.

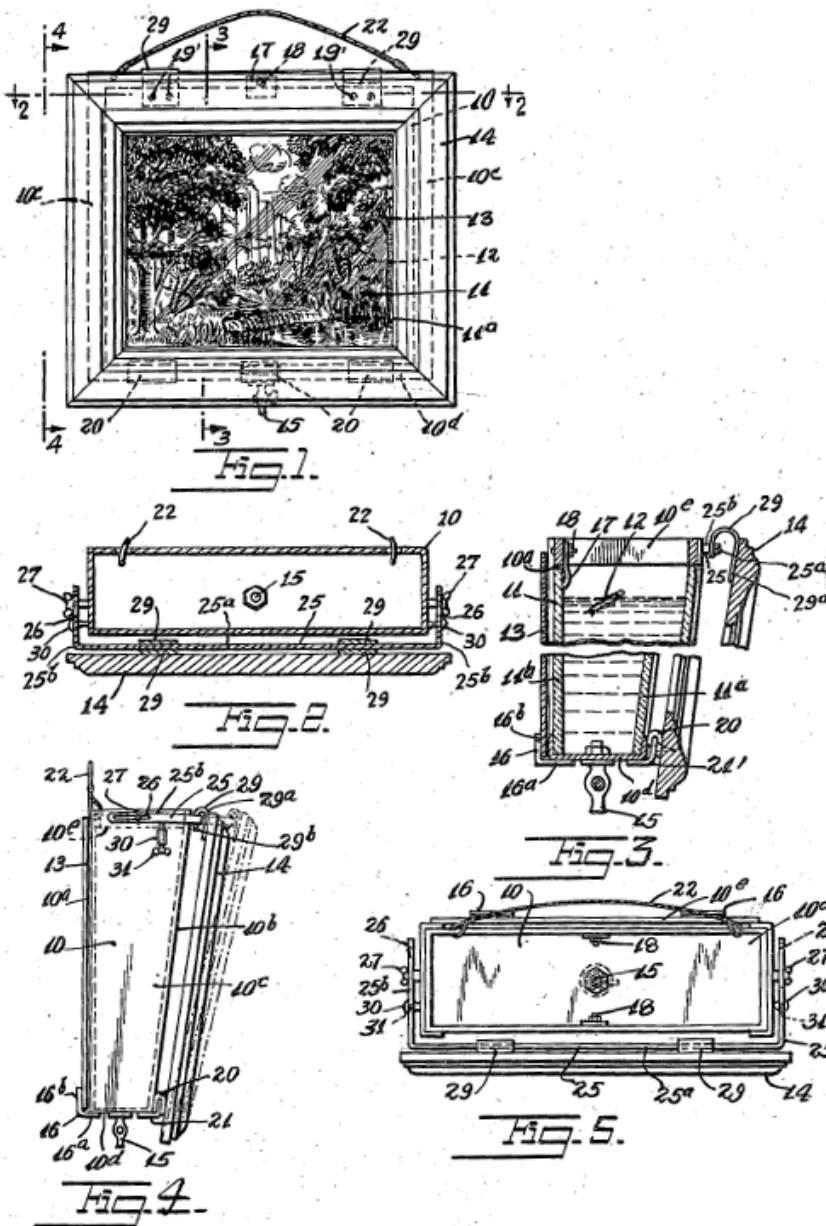

Figure 134: Morris Skolnick's wall aquarium, 1937.

The invention provided a novel manner for attaching a removable picture to the rear of an aquarium and a removable picture frame to its front and then supporting the entire device on a wall so that both the picture and the frame could be removed while the aquarium was cleaned, thus preserving the picture and the frame.

Another object of the invention was to have the front of the frame structure at an angle to the bottom wall and then support the picture frame on the front parallel thereto so that the frame would assume a position which was customary when hanging picture frames.

Still further the invention provided for a drain cock to be mounted in the bottom wall of the aquarium to permit the water to be drained and changed without removing the device from the wall.

There were, of course, a number of inherent problems with wall aquariums: (1) they had to be firmly attached to the wall studs (and many houses of the time had plaster lath walls where the studs were hard to locate), (2) the tanks had to be located where studs were available, (3) the tanks were necessarily small because their widths had to be narrow, and (4) they had to be located where furniture did not interfere with access to the tanks. Because of these problems, these designs were of limited use.

[Figure 135, *Design for a Combination Aquarium and Fernery Stand, Number D78013*] Six designs for aquarium stands were patented during this decade, starting with that of Harvey H. Downie of Seattle, Washington in 1929. These were all Design Patents so there was no description accompanying any of them;

[Figure 136, *Stand for Fish Bowls or Similar Articles, Number D78682*] Lewis E. Wackerle of Chicago in 1929 for three mermaids holding a fish bowl (*Stand for Fish Bowls or Similar Articles, Number D78682*);

[Figure 137, *Fish Bowl Standard, Number D80395*] Joseph Schlagheck of Toledo Ohio in 1930 for marine creatures holding a fish globe;

[Figure 138, *Aquarium Stand or Similar Article, Number D80865*] Sanders C. Simpson of Woodcliff, New Jersey in 1930 for two nudes holding a flat-sided fish bowl;

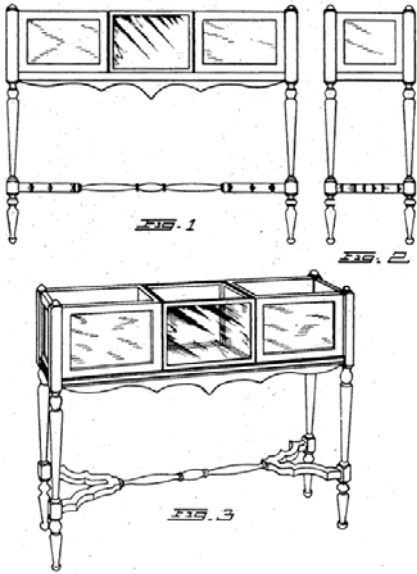

Figure 135: Harvey H. Downie's aquarium stand, 1935.



Figure 136: Lewis E. Wackerle's aquarium stand, 1929.

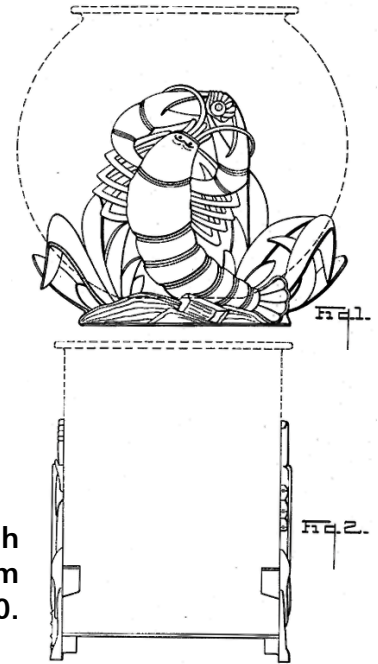

Figure 137: Joseph Schlagheck's aquarium stand, 1930.

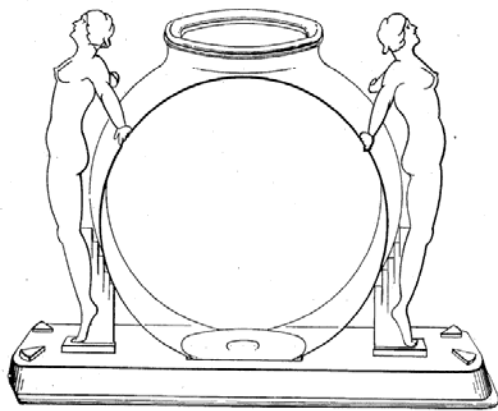

Figure 138: Sanders C. Simpson's aquarium stand, 1930.

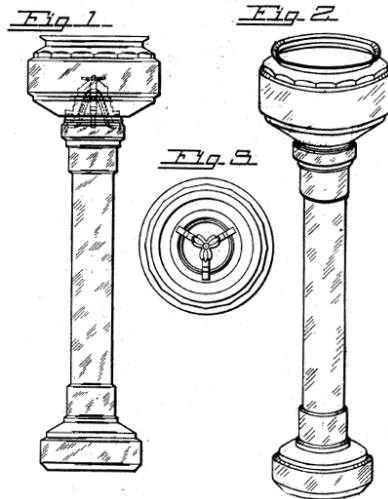

Figure 139: Roy E. Castetter's aquarium stand, 1931.

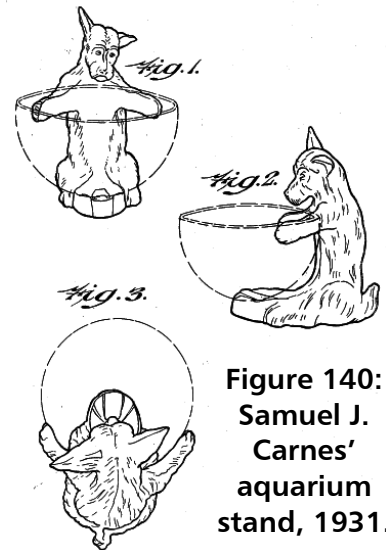

Figure 140: Samuel J. Carnes' aquarium stand, 1931.

[Figure 139, *Design for an Aquarium*, Number D85413] Roy E. Castetter of Wyoming, Ohio in 1931 for a simple bowl on a column-like stand. Note that Castetter did not identify the odd triangular object in his Figure 3;

[Figure 140, *Design for a Fish Bowl*, Number D100200] This one was by Samuel J. Carnes of Camden, Arkansas in 1936 for a dog holding a fish bowl.

[Figure 141, *Aquarium*, Number 1858181] We now examine a number of novelty aquariums that seemed to be the rage during this decade. The first was the 1932 brainchild of Gaspar R. Bossetta of New Orleans, Louisiana 1932. Bossetta's design showed a twelve-sided aquarium with a glass figurine of a bird above it. When the time came for water change, the bird was filled with water at its tail, the water dripping from its beak into the aquarium, thus providing aeration as well. One leg of the bird served as an overflow tube for the excess water.

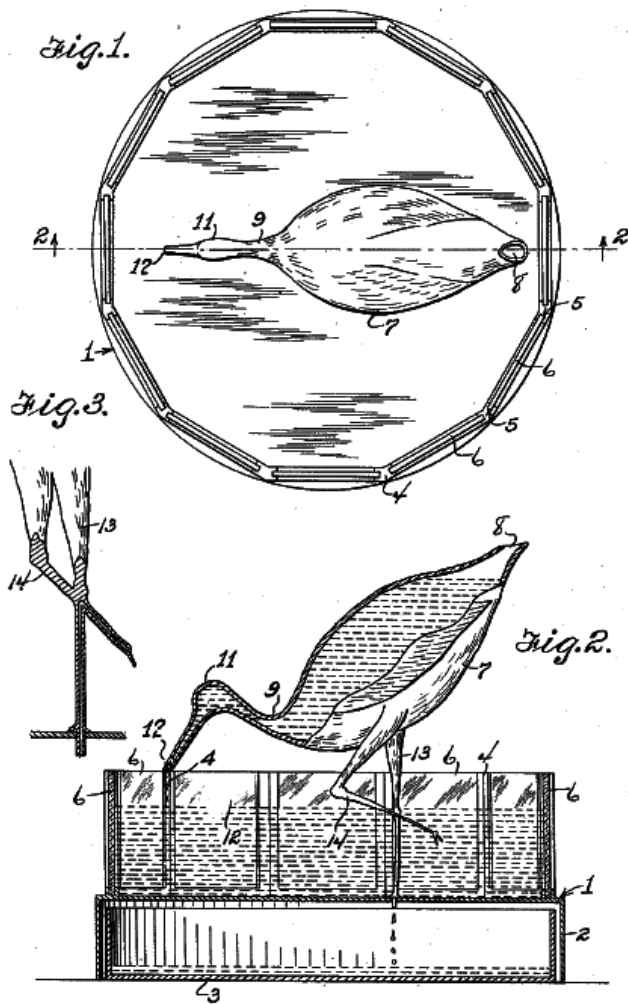

Figure 141:
Gaspar R. Bossetta's novelty Aquarium, 1932.

Figure 1 is a top plan view of the aquarium that forms the subject matter of the invention, Figure 2 is a sectional view taken approximately on line 2 - 2 of Figure 1 looking in the direction of the arrows and Figure 3 is a fragmentary sectional view illustrating the drainage means for the aquarium.

The aquarium was not only attractive and ornamental in appearance, but provided for a change of the water within the bowl. This was brought about by filling the body of the bird 7 with water as shown in Figure 2. Consequently the water would drip from the bill of the head 11 within the bowl. As the water within the bowl rose to a height where it was above the juncture of the tubular portions of the legs 13 and 14, a siphonic action took place and the water was drawn up through the tubular portion of the leg 14 and passed

down through the tubular portion of the leg 13 to the receptacle below that could be emptied by merely lifting the bowl from the base when it became necessary to do so. Thus the water within the bowl would be constantly changed as long as the hollow bird 7 contained water. The fish were not disturbed in any manner and the water introduced within the bowl from the body of the bird was practically the same temperature as the water within the bowl and so was beneficial for the health of fish.

[Figure 142, *Design for an Aquarium, Number D82230*] Four of these novelty designs emerged from the imagination of Larry Venditti of Philadelphia. In all of these designs the aquariums were covered with stones that made them look like miniature grottos, and a light bulb enclosed in a glass bell jar was built into the bottom of each of them to provide illumination. His first and second designs were Design Patents. His first design (1930) was of a trapezoidal shape;

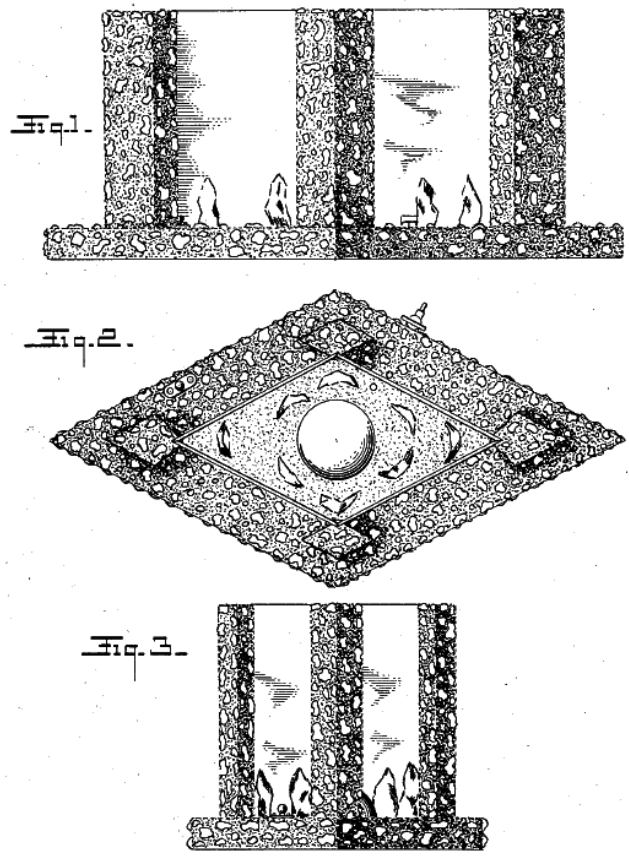

Figure 142: Larry Venditti's first novelty aquarium, 1930.

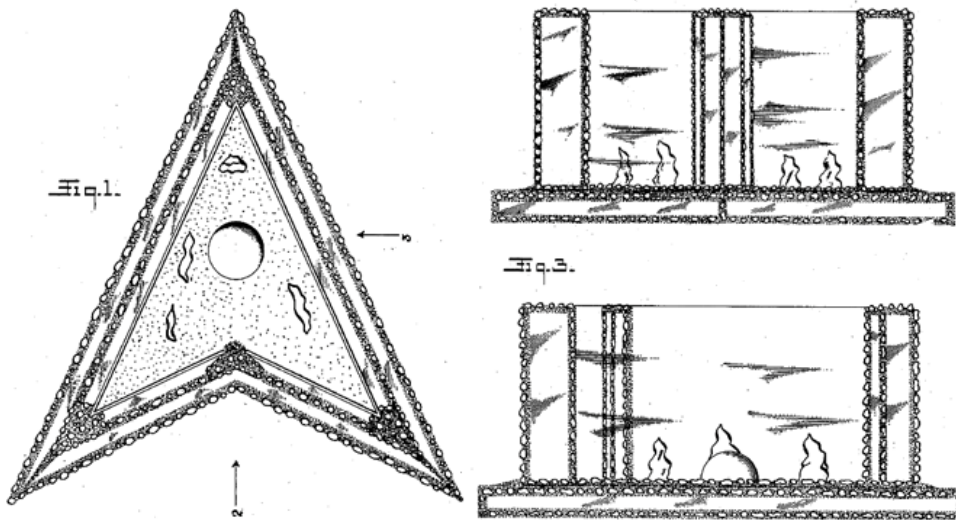

Figure 143: Larry Venditti's second novelty aquarium, 1930.

glass and posts would be increased. These plates of glass or other suitable media were secured in position by having their lower edges engaging the shoulders 11, and their vertical edges the several posts 12. They were secured and maintained against leakage in the usual manner by the use of the cementitious material indicated at 16.

Within the body of the aquarium defined by the several plates of glass was

[Figure 143, *Aquarium*, Number D83137] His second design (1931) was in the shape of an arrowhead;

erected an illuminating element comprising a trans-

[Figure 144, *Aquarium*, Number 860698] His third design (1932) was in the shape of a triangle. Note that this and the following were Utility Patents.

Figure 1 is a view in side elevation of one embodiment of the invention, Figure 2 is a top plan view shown in Figure 1, Figure 3 is a sectional view taken through to the light chamber showing the reflecting and refracting bodies embedded in the base, and Figure 4 is a fragmentary inverted plan view showing the manner of mounting the illuminating element in the body.

Erected upon the base 10 was a plurality of posts 12, the number of such posts being determined by the polyangularity of the device. In the drawings, such posts were shown as three in number and in such triangular construction; a plate 13 of glass formed one of the sides indicated in the drawings as the front, while the other plates of glass 14 and 15 formed two other sides. If the number of sides was greater than three, then the number of plates of

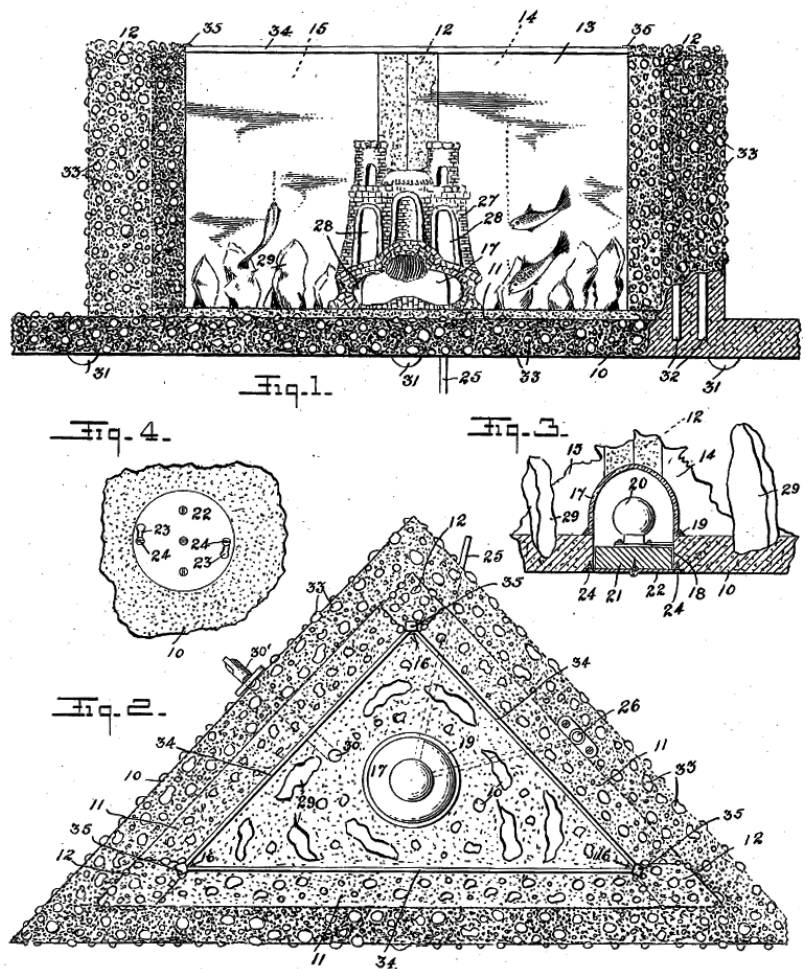

Figure 144: Larry Venditti's third novelty aquarium, 1932.

parent dome **17**, which was erected over an opening **18** in the bottom of the base **10** and rendered leak proof by the usual cementitious material. Within this dome a light element **20** was inserted and attached to a block **21**. The block had a plate **22** connected with key hole slots **23** engaging fastening members such as screws **24** embedded in the material of the base **10**. By a rotation of the amplitude of the key hole slot **23**, the plate **22** could be inserted or removed and locked therein. Wiring **25** was indicated in the drawings, with a switch **26** for controlling the current to the lighting element **20**.

The dome **17** was covered by an ornamental device, indicated at **27**, with openings **28** through which the light from an illuminating element would pass and into engagement with reflecting and refracting bodies **29** that were embedded permanently and rigidly in the base **10**. Rocks such as flint, quartz or the like, having reflecting or refracting facets could be employed, but there was no limitation upon the use of other reflecting or refracting bodies.

For the purpose of evacuating the aquarium, a conduit **30**, terminating in a spigot **30'** was provided so that the water could be drawn from the aquarium as was deemed desirable. Also, the device being constructed of concrete or like plastic material would be of rough nature and would tend to mar tables and the like, so for the purpose of preventing this, feet **31** were provided in the nature of semi-spherical rubber tips. To strengthen the structure, reinforcing could be inserted, such reinforcing being indicated at Figure 1 by the bars **32** extending from the post **12**, in the homogeneous mass and into the bottom or base **10**. The employment of such reinforcing was no indication of other than monolithic structure but merely that the monolithic structure was thereby strengthened and made more rigid. The material referred to as concrete while still in a plastic condition, could be ornamented further by applying thereto pebbles **33** or other like ornamental members. These pebbles could be of any size, actual or relative, and could be of any color or colors that fancy may dictate.

The upper edges of the transparent sheets were finished, strengthened and protected by channels **34**,

which simply embrace the upper edges of the sheets. To maintain those channels in position, strips of metal **35** were embedded in the posts **12** when being molded. After the channels **34** were in position, these strips **35** were bent downwardly and soldered across the junction of the adjacent channels. According to Venditti, the device had a near approach to natural appearance and provided quarters in which the aquatic animals would be more content to live and therefore have their lives prolonged.

[Figure 145, *Aquarium*, Number 1908939] His fourth design (1933) also was in the shape of triangle but three vertical posts were added that held the aquarium up a short distance from the table. The posts in this version were made of a translucent or transparent material so lamps could be enclosed in these as well if desired. Venditti stated that his aquaria could also be designed in other shapes.

Figure 1 is a top plan view of one embodiment of the invention, Figure 2 is a view shown as indicated by arrow 2 at Figure 1 seen in elevation, Figure 3 is a sectional view taken on line 3 - 3 of Figure 1, Figure 4 is an inverted plan showing a fragment of the base and the manner of inserting and securing the illuminating element therein, Figure 5 is a top plan view of a base of a slightly modified construction, Figure 6 is a **sectional** view **taken** on line 6 - 6 of Figure 5 and Figure 7 is a sectional view taken on line 7 - 7 of Figure 5 showing the container in position.

A supporting base was provided that included a table structure of any size and shape. As shown in Figures 1 to 4 inclusive, this formed a triangular base **10**, but the invention was not limited to a triangular form. About the margin of the table **10** an upstanding rib **11** was provided, forming a depression conforming in general shape to the shape of the base. At the several corners, posts **12** were erected. These posts conformed in number to the shape of the base, and the showing in the drawings of three of these posts was merely in conformance with the triangular shape and was no limitation upon the invention. The posts were provided with vertically disposed grooves or guide ways **13**, and the posts themselves could be of any construction desirable. The posts were of hollow

construction and under some conditions could, if constructed of transparent or translucent material, be used for containing an illuminating element.

Through the bottom of the table 10 an opening 14 was provided, and an illuminating element indicated at 15 as an electric bulb was inserted through. This illuminating element could be supported therein and thereby raised to a predetermined height above the level of the table in any manner. As shown, a socket 16 was provided, supported by a strap 17 and as shown at Figure 4, cut-outs 18 permitted the insertion through of tongues 19 carried at the extremities of the strap. By inserting through these cutouts 18 and giving a partial turn, the illuminating element would be retained in position.

The container was an integral structure as shown at 20 and, to function properly as an aquarium, was constructed of glass. In the bottom and upstanding therefrom, a dome 21 was erected and positioned to cover the illuminating element 15 when the container was in position. At Figure 2 this container was shown as partially lifted from its normal position, indicating that the container could be removed from the base for cleaning or the like, and by such lifting as shown, exposed the illuminating element that was wholly enclosed when the container was in the normal position.

In the modified type shown at Figures 5 to 7 inclusive, the base was of slightly different construction. As shown, a table 23 was provided having at the corners upstanding posts 24. These posts 24 differed from the posts 12 in that they were simply curved members or plates embracing the corner of the container 20. These posts 24 would extend only a limited distance from the base as distinguished from the posts 12 that were shown as extending the length of the container. Under the table 23 a supporting arrangement would be provided. At

the corners, parts analogizing legs 25 were shown and intermediate the corners, other parts 26. This base, while conforming to the general shape of the container, would be supported by any type of supporting structure. Parts 25 and 26, as shown, were merely illustrative. Whatever the structure, a rib 27 would be interposed between the several posts so that the container 20 would fit more or less snugly within this rib, which in conjunction with the posts was continuous throughout the entire margin.

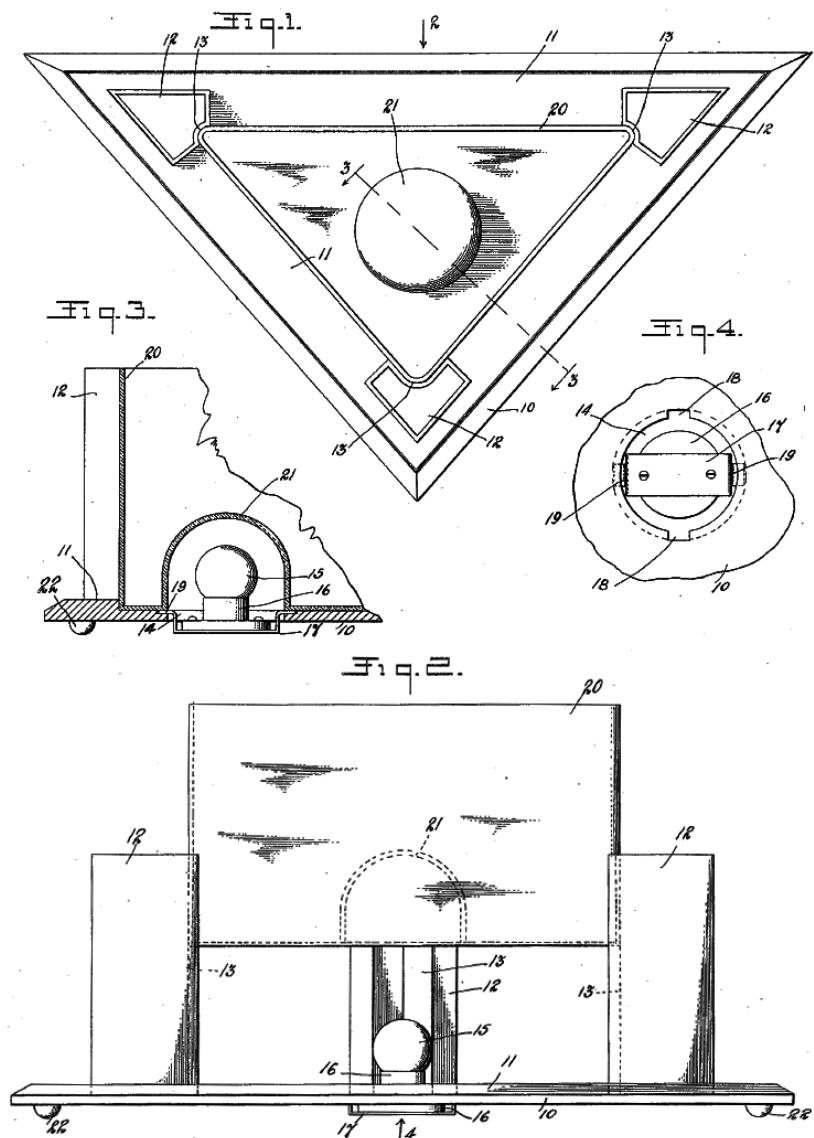

Figure 145:
Larry Venditti's fourth novelty aquarium, 1933.

[**Figure 146, Combined Table and Aquarium, Number 2133740**] The first table aquarium design was assigned to Stephan E. Donohoue of Charleston, West Virginia in 1937 (Number 2133740). Unfortunately, Donohoue did not supply any details as to how access to the aquarium for feeding and cleaning was obtained. The assumption is that the glass top attached to the support legs was simply lifted off the aquarium. The possibility for breakage during such maneuvers was, of course great, since table glass of this size is heavy.

Fig. 1 was a perspective view of the invention, Fig. 2 was a top plan view, Fig. 3 was a sectional view taken on the line 3 - 3 of Figure 2, Fig. 4 was a side elevation of the table frame and Fig. 5 was a top plan view of the table frame.

The frame of the table 5 had supporting legs 6 connected together at the upper and lower ends by means of upper and lower circumferentially extending members 7 and 8 respectively. The lower ends of the legs were offset to form feet 9 for resting the device on a floor surface. The upper and lower members were constructed of a substantially cylindrical upper member being of a greater diameter than the lower member. The legs intermediate of the upper and lower ends thereof were offset and inclined upwardly and outwardly for jointure with the upper member. Interposed between the legs and extending between the upper and lower members was a reservoir 10 of an elongated cylindrical configuration and constructed of glass to form an aquarium.

The aquarium was provided with water, in which species of aquatic animals such as goldfish were adapted to be contained. Mounted on the upper member above the upper end of the aquarium was a table top 11 constructed of glass. The upper end of the aquarium was spaced from the top to provide an air passage 12 whereby air, necessary for the aquatic animals contained in the aquarium, was permitted to be circulated through. The top 11 provided a guard to protect the upper end of the aquarium and at the same time permitted of a view of its contents. Furthermore, the weight of the liquid contained in the aquarium served to prevent accidental overturning of the device. By

means of the transparency of the top and the aquarium, a view of the contents of the reservoir could be had from any position.

[**Figure 147, Miniature Aquarium, Number D83044**] A plethora of design patents for novel aquariums characterized this decade, including those of Hans C. Jensen of Chicago in 1930, an aquarium in the form of a house;

[**Figure 148, Fish Bowl, Number D84002**] Floyd G. Smith of Petersburg, Florida in 1931, two tanks connected via two tubes the fish could swim through;

[**Figure 149, Aquarium, Number D85201**] Valerius Pomernacki of Chicago in 1931, an aquarium shaped like a boat;

[**Figure 150, Fish Bowl, Number D86002**] Charles M. Wibel of Mount Pleasant, Pennsylvania in 1932, an aquarium shaped like a fish;

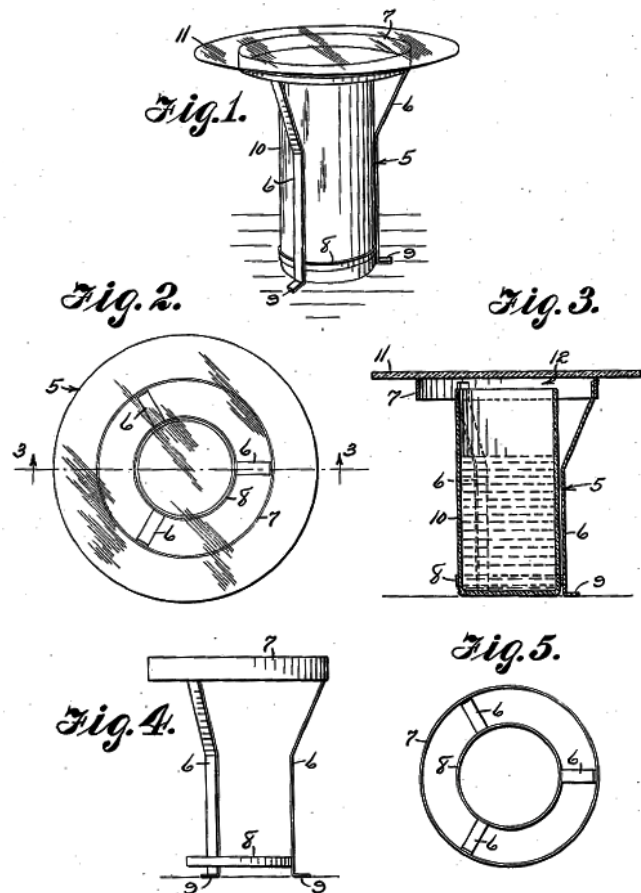

Figure 146: Stephan E. Donohoue's table aquarium, 1937.

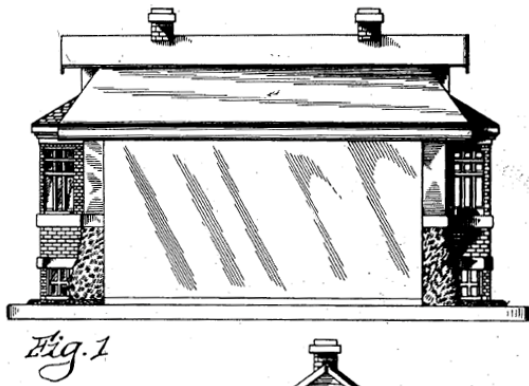

Figure 147:
Hans C. Jensen's
novelty aquarium
design, 1930.

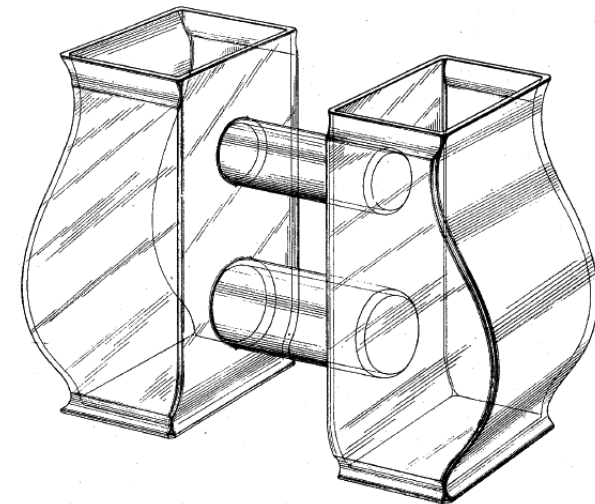
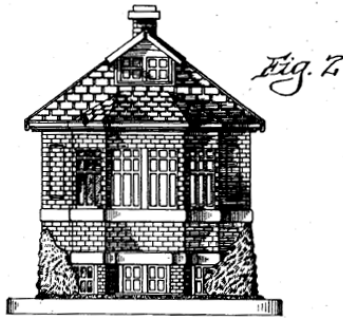

Figure 148: Floyd G. Smith's novelty aquarium
Design, 1931.

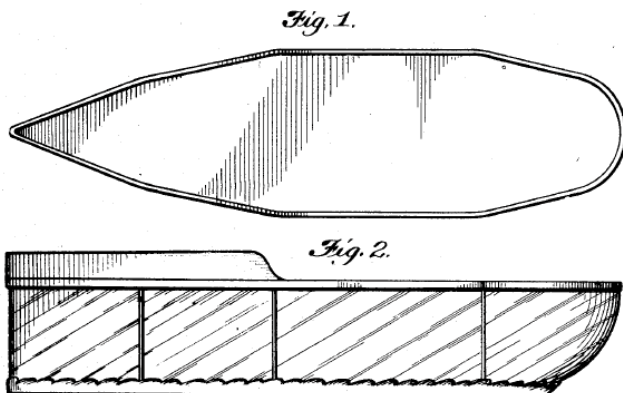

Figure 149: Valerius Pomernacki's novelty
aquarium design, 1931.

[Figure 151, *Fish Bowl*, Number D90032] Soovia Janis of New York City in 1933, a bear holding a fish bowl;

[Figure 152, *Aquarium*, Number D90041] Russel Wright in 1933, an aquarium in the form of a horizontal tube;

[Figure 153, *Fish Bowl*, Number D90646] Two from Samuel J. Carnes of Camden, Arkansas in 1933, a cat looking over a fish bowl (*Fish Bowl*, Number D90646) and

[Figure 154, *Fish Bowl*, Number D90647] and a bird overlooking a fish bowl;

[Figure 155, *Aquarium*, Number D92416] E. McCormick of New York City in 1933, (an aquarium in the shape of a porthole);

[Figure 156, *Aquarium*, Number D92776] Oscar M. Shannon of Larchmont, New York in 1934, an aquarium in the form of a treasure chest;

[Figure 157, *Aquarium*, Number D93033] Henry I. Miller of St. Louis, Missouri in 1934, a twelve-sided aquarium;

[Figure 158, *Aquarium*, Number D94058] Arthur P. Swanson of Maine Township, Illinois in 1935, an Art Deco design;

[Figure 159, *Aquarium*, Number D94248] and another by him in 1934, an aquarium in the shape of an alarm clock;

[Figure 160, *Fish Bowl or Similar Article*, Number D95727] Charles P. Askew of Marion, Indiana in 1935, an aquarium in the shape of a submarine;

[Figure 161, *Fish Bowl*, Number D97759] Samuel J. Carnes of Camden, Arkansas in 1935, a globe aquarium within a fish;

[Figure 162, *Combined Fish Bowl and Stand*, Number D98718] Lester K. Franklin of Chicago

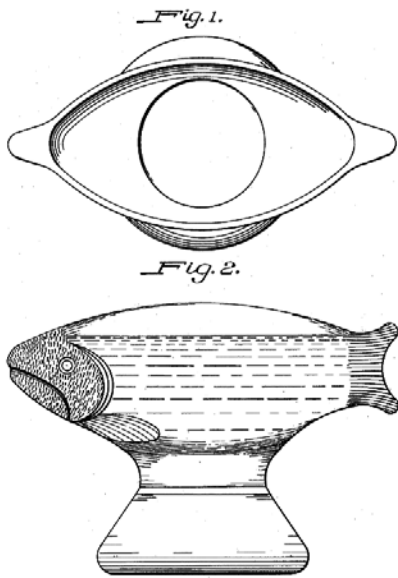

Figure 150:
Charles M. Wibel's novelty
tank, 1932.

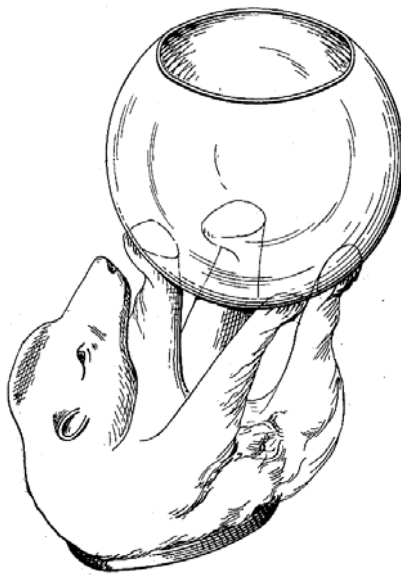

Figure 151: Soovia Janis'
novelty tank, 1933.

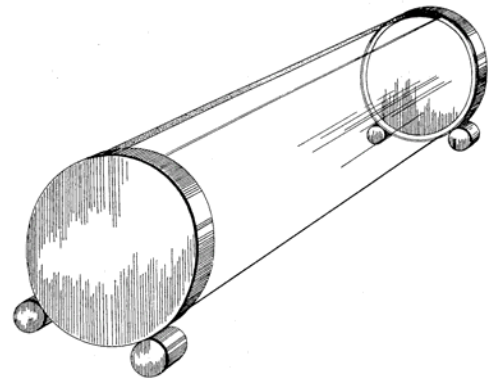

Figure 152:
Russel Wright's horizontal tube
aquarium, 1933.



Figure 153:
Samuel J. Carnes' novelty tank,
1933.



Figure 154: Samuel J. Carnes's
second novelty tank, 1933.

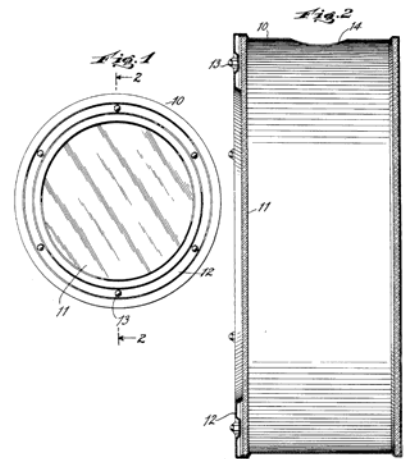

Figure 155: William E.
McCormick's porthole tank,
1933.

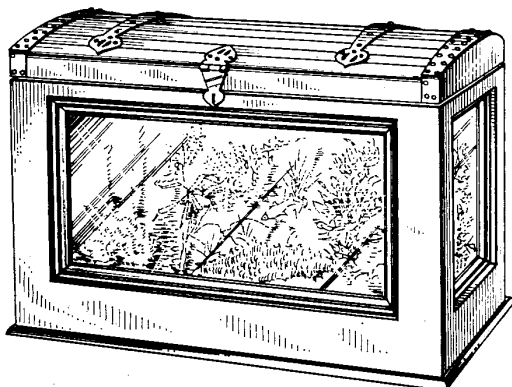

Figure 156: Oscar M. Shannon's
treasure chest tank, 1934.

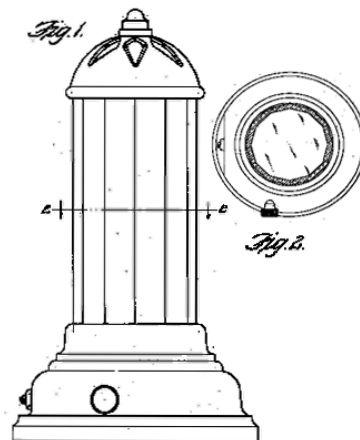

Figure 157: Henry I.
Miller's twelve-sided
aquarium, 1934.

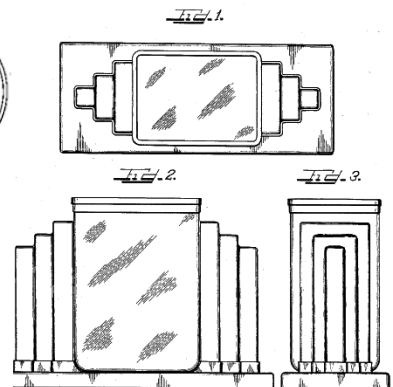

Figure 158: Arthur P.
Swanson's Art Deco
Design, 1934.

in 1936, a fish bowl on a stand containing a flamingo and cattails and

[Figure 163, *Combined Clock and Vase*, Number D96947] Leopold Weiss of New York City in 1935 invented a hanging aquarium with a built-in clock. Since these were all design patents, there are no details other than what can be seen in the drawings.

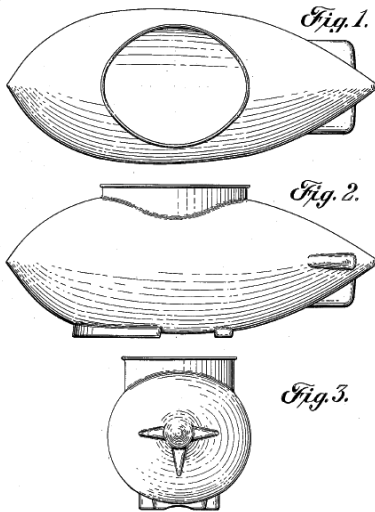

Figure 160: Charles P. Askew's submarine aquarium, 1935.

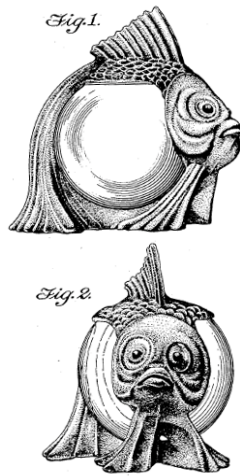

Figure 161: Samuel J. Carnes fish globe within a fish, 1935.

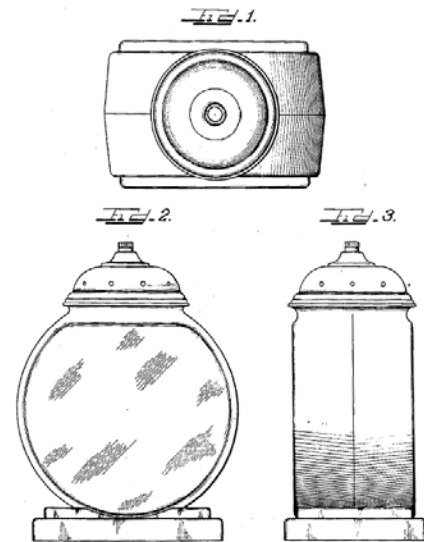
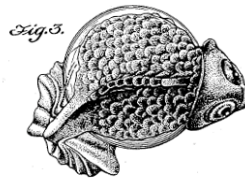

Figure 159: Arthur P. Swanson's alarm clock aquarium, 1935.

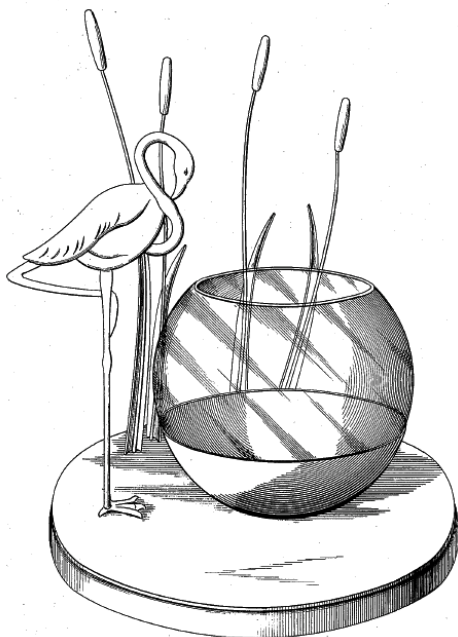

Figure 162: Lester K. Franklin's globe with a flamingo, 1936.

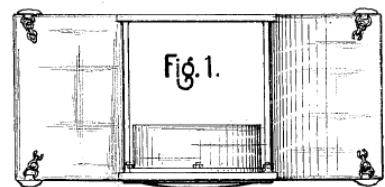
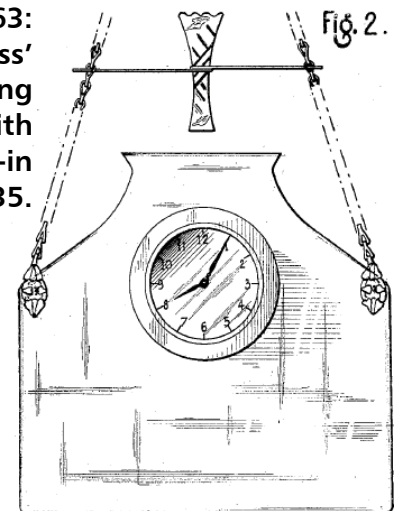

Figure 163: Leopold Weiss' hanging Aquarium with built-in clock, 1935.





WORLD WAR II: THE DECADE OF 1939-1948

[Figure 164, *Aquarium Conditioner*, Number 2172799] This was the decade of World War II and performe the number of aquarium patents dwindled to a mere trickle compared to the previous ten years, i.e., 13 versus 75. We'll start off with three patents that dealt with aeration and filtration.

The first was issued to John L. Magnus of Washington, DC in 1939. It is interesting to quote from the inventor: "...aeration of aquariums is becoming recognized as essential in this industry or hobby." Magnus, a well-known name in the hobby in the previous decade, designed an aeration scheme that aerated from beneath the surface of the water and above as well. He accomplished this by designing a fan that incorporated an air pump, using the fan blade shaft to power the piston of the air pump. The fan was directed across the surface of the water, cooling it by evaporation. This was a very ingenious design, although bulky and cumbersome in its implementation.

Fig. 1 is a view in side elevation of the conditioner and aerator operative-ly mounted in conjunction with an aquarium, Fig. 2 is an enlarged view in rear end elevation of the device, Fig. 3 is an enlarged fragmentary sectional view taken substantially on the line 3 - 3 of Fig. 2, Fig. 4 is a detail view in transverse vertical section through the pump plunger and co-acting parts, Fig. 5 is a detail perspective of a preferred type of connecting

member for the plunger, Fig. 6 is a sectional view of a preferred type of check valve and Fig. 7 is a similar view of a valve for regulating the exhaust of air beneath the water.

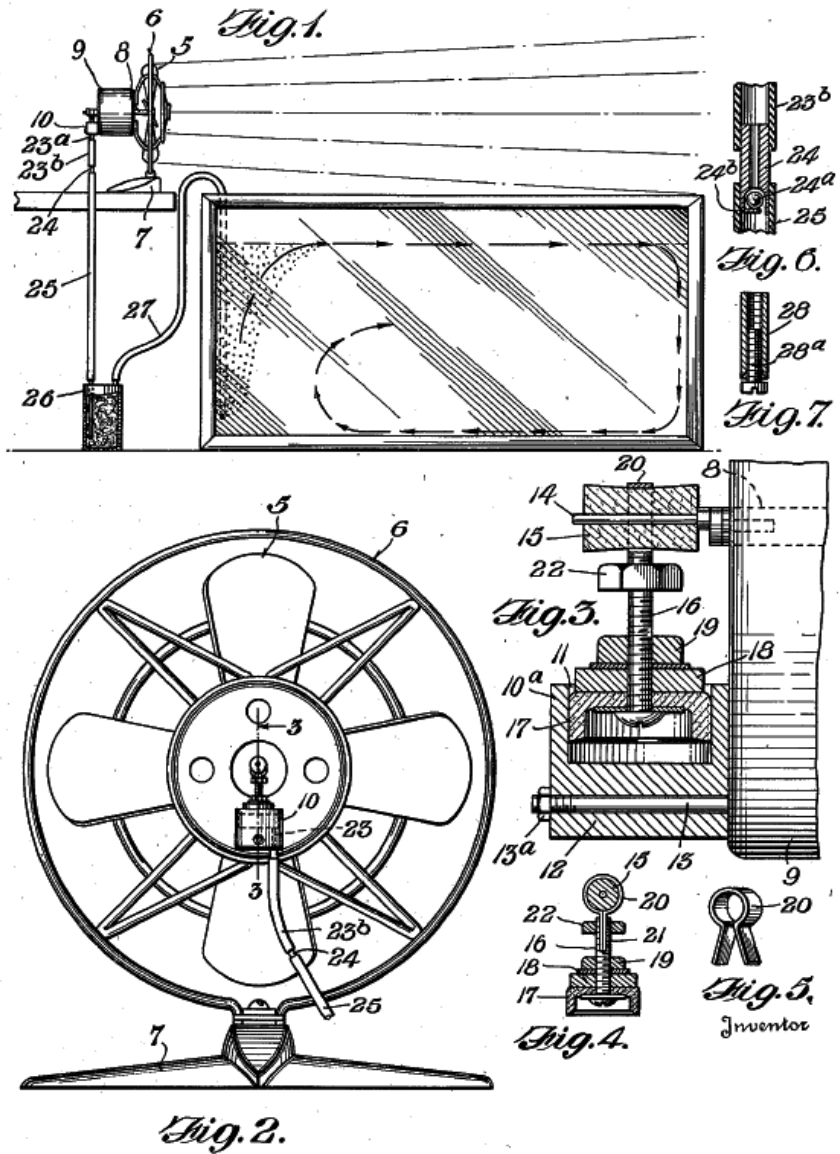

Figure 164: John L. Magnus' fan aerator and filter, 1939.

The number **5** designated a fan, which could be of any size suitable to obtain the proper volume or velocity of air in accordance with the size of the aquarium being aerated, the fan in the present instance being provided with the conventional guards or frame **6** that was mounted on a stand or pedestal **7**. The fan shaft was indicated at **8**, the shaft being driven by a motor, preferably electric, the housing of which was indicated at **9**.

Mounted on the rear wall of the housing **9** was an air pump, generally indicated at **10**, the construction of the pump being best shown in Fig. **3**. The pump assembly comprised a cylindrical housing or casing **10a** having a cylindrical chamber **11** and a base **12** which was transversely bored to receive a bolt or screw **13** that was secured to the housing **9** at its inner end and at its outer end was screw threaded to receive a securing nut **13a**. The rear end of the fan or armature shaft **8** had connected to or formed as a part thereof an eccentric or crank shaft **14** having mounted thereon a bushing or bearing **15** that will subsequently be more fully described. The piston or plunger assembly comprised a connecting rod **16** having mounted on the lower end thereof a plunger valve **17** of flexible material such as soft leather or the like, the valve being clamped against a head or disc **18** and locked in position by means of a nut **19**. The valve **17** contracted and admitted air to the chamber **11** on the upstroke of the plunger or piston and expanded and sealed the chamber on the down or work-stroke of the piston.

In a construction of this kind, it was essential that the parts ran quietly throughout the life thereof, one of the faults common to motor-driven aerators being that within a relatively short time bushings or bearings develop wear with the result that the parts vibrated and became noisy and soon rendered the device useless. Since the pump operated very rapidly, or in fact consisted of a series of pulsations, once wear developed and vibration set in, within a comparatively short time the parts would loosen and require renewal. This objection was overcome by utilizing a relatively soft fibrous bearing, such as a piece of felt, which was impregnated with oil and mounted on the shaft. Connection with the pump

plunger was made by means of a flexible band **20** which had its opposite ends brought together and inserted in a slot **21** formed in the upper end of the connecting rod **15**, the band being adjustably clamped in position by means of a nut **22**. This type of bushing would wear almost indefinitely without developing the slightest noise or vibration. Should an adjustment be desired, it could be accomplished in a very simple manner by taking up on the meeting ends of the band **20**. If the bushing was renewed, the cost was practically negligible.

The base of the pump cylinder **10a** was formed with an outlet passage or opening **23** (note Fig. 2). Attached to the lower end of this passage was a tubular member **23a** having connected thereto a tube length **23b** which carried a check valve shown in detail in Fig. **6** and consisting simply of a small tubular housing **24** that was bored and had placed in the lower end thereof a ball valve **24a** held in position by an in-bent segment **24b** of a split flange formed on the lower end of the housing **24** as a result of the milling or cutting-out operation when forming the ball housing. While the valve **24** could be installed directly in the passage **23**, the type of installation herein shown facilitated removal and cleaning and also deadened any sound that resulted due to the operation of the valve.

A conduit consisting of a length of flexible tubing **25** connected with the lower end of the valve **24** and led down to a combined pressure tank and muffler **26** (note Fig. 1) and from this tank **28** another conduit or length of flexible tubing **27** led into the aquarium and at its lower end was provided with an adjustable outlet valve that consisted simply of a screw threaded housing **28** having a screw **29a** loosely and adjustably mounted therein (note Fig. 7). The tank **27** ensured a steady, non-pulsating supply of air with a minimum of disturbance at the valved outlet of the conduit, while the outlet valve provided a simple means for adjusting the volume of air admitted into the aquarium. To further deaden the pump pulsations, there was inserted a deadening medium, such as steel wool or like fibrous material in the tank **26** and extended the end of conduit **25** well down into the tank (note Fig. 1).

When the fan was turned on the pump plunger was reciprocated rapidly, building up air pressure in the combined tank and muffler 26, the air passing into the aquarium in accordance with the adjustment given the valve 28. At the same time fresh air was blown over the surface of the water. Since a draft of air was continuously drawn past the pump, fresh air only was taken into the air intake, and as the carbon dioxide and other noxious gases were brought to the surface by the aerating action beneath the surface, such gases were immediately dissipated and at the same time circulation of the water was facilitated or expedited (note the cycle indicated by the arrows in Fig. 1). Thus the device aerated and conditioned both beneath and above the surface of the water. This arrangement also provided an air cooled motor for the pump as an incidental feature in conjunction with the other important advantages brought about by the use of the fan.

Another feature of advantage was that by adjusting the height of the lowermost point of reciprocation of the plunger 17 in the cylinder 10a, the pressure generated by the pump could in turn be adjusted. This was brought about due to the fact that the closer the plunger reciprocated to the bottom of the casing, the more effective would be the checking action of the ball valve 24a, so that there would be less back pressure on the plunger. This adjustment could be effected by loosening nut 22 and relatively moving rod 16 on ends of band 20.

The entire apparatus or unit could be economically produced and filled a marked need in the ever-growing hobby or industry. The fact that the driving means or motor was common to both the pump and fan contributed materially to low cost production and operation.

[Figure 165, *Aerating and Filtering Device for Aquariums, Number 2253516*] A combination aeration and filtering system was developed by another well-known aquarist of the day, James F. Haldeman of Martinsville, Indiana in 1941. The aeration was produced by an air/water injector, the water supplied by the aquarium itself. Since the aquarium water also circulated below the tank, it was filtered in a chamber located at position F in Figure 1. The filter was designed so that it could be backwashed and cleaned without removal of the filter medium. There was a

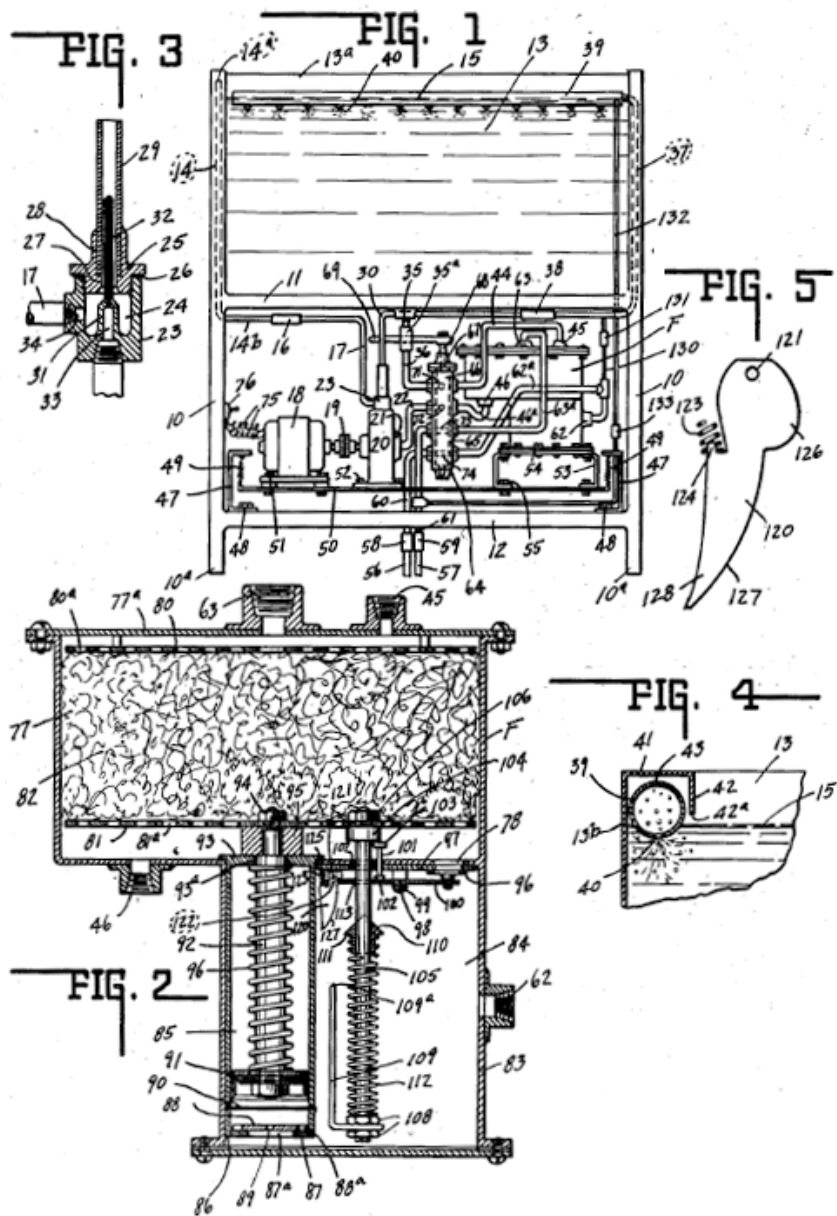

Figure 165:
James F. Haldeman's aeration and filtration system, 1941.

filtration and aeration cycle and also a filter washing cycle, using the opening or closing of a valve to switch between cycles. The design also ensured that any splashing of the water from the air/water injector was minimized. Furthermore, the equipment was mounted in such a fashion as to minimize any vibrations that might be conveyed to the aquarium. This was an ambitious design, but one better suited to large aquariums.

Fig. 1 is a front view of an aquarium structure embodying one form of the invention, the aquarium structure being shown more or less skeletonized and devoid of ornamental characteristics, Fig. 2 is an enlarged central sectional view of the filter structure with the washing and compressing apparatus incorporated therein, Fig. 3 is an enlarged central sectional view of a positive aeration means, Fig. 4 is an enlarged transverse, sectional view of the aquarium tank and the aerated water discharge thereto and the means for preventing splashing and the relief of excess air without splashing and Fig. 5 is an enlarged side elevational view of a lock element.

This patent had many pages of the details of its construction (as well as complicated figures) so the text will not be presented here. However, the following were the objects of the inventor. (1) The first feature was that the discharge to the aquarium tank of aerated filtered water was in such a manner that splashing was prevented, (2) A second feature was that the mixing of air and water was made in an arrangement in such a manner that the mixing was devoid of splashing, (3) A third feature was mounting the power, pump and other associated equipment so that the power and pump vibrations were absorbed to a considerable degree, if not entirely eliminated and so were not transmitted to the aquarium tank and its contents, (4) A fourth feature consisted in the inclusion of a filtering structure wherein the filtering medium could be cleaned by compression and washing without removal of the medium, (5) A fifth feature consisted in providing such a filter structure with washing fluid operable means so that the washing fluid supplied the power for the medium compression, (6) A sixth feature consisted in embodying in a filter structure a control arrangement whereby the

filtering medium was alternately compressed and washed, such cycling being automatic, (7) A seventh feature consisted in providing a control arrangement whereby the embodiment of the invention readily could be shifted from normal aquarium content aerating and filtering cycling to filtering medium compression and washing cycling, and (8) An eighth feature of the invention consisted in the positive aeration of altered aquarium water, the aeration in an amount sufficient to at least fully saturate the water and generally provide an excess of oxygen thereto so that the water previous to its return to the aquarium supply had absorbed the fullest amount of oxygen possible.

[Figure 166, *Filter and Aerator, Number 2732341*] The creation of Donald W. Huff of Peekskill, New York in 1946 was an odd one, a combination filter and aerator in the form of a windmill. The air from an air pump (not shown) entered the center tube (12) from an airline (16). The air lift drew water

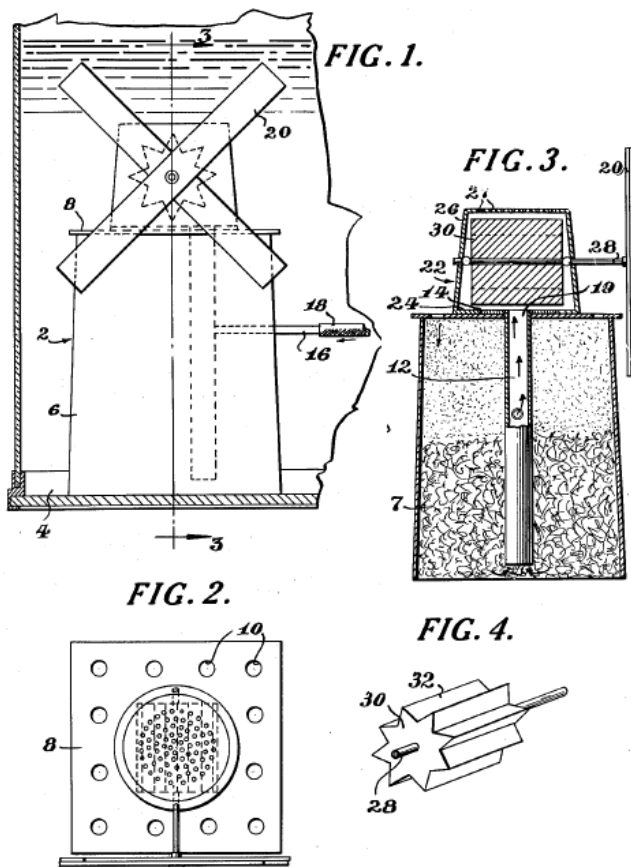

Figure 166: Donald W. Huff's windmill aerator and filter, 1946.

up into the filter, the water being drawn into the filter via the holes (10), and then in the process of falling down hit the cam shown in Fig. 4, rotating it and thus driving the windmill. The aerated water entered the tank via the holes in the cam housing. Huff claimed that the windmill arms would serve to agitate and circulate the water. Although there is no reason to think that this invention would not work, I'd place it in the Rube Goldberg category although it would certainly be a conversation piece at any party.

Figure 1 is a partial side elevational view of an aquarium provided with a device made in accordance with the present invention, Figure 2 is a plan view, Figure 3 is a vertical cross sectional view on the line 3 - 3 of Figure 1 and Figure 4 is a perspective view of a part of the means used for driving the windmill arms.

The windmill **2** comprised a filter housing or container **6** that could take any desired shape although, in the particular embodiment shown, it was substantially square. As shown, container **6** was closed at the sides but open at the bottom to permit the insertion of appropriate filtering material **7**, e.g., charcoal and/or glass wool, within the container.

Container **6** could be made of metal or any other suitable fabricating material, preferably a plastic material, such as Bakelite, appropriately colored to conceal tube filtering material **7**. Container **6** was also provided with an upper wall **8** having a plurality of apertures **10** therein, as best shown in Figure 2. This upper wall **8** constituted an integral part of the container **6**. However, if desired, it could be a separate member that was simply laid over the upper end of the container. In the latter event the container could, if desired, be provided with a bottom wall since the filtering material could then be placed within and removed from the container through the upper end thereof.

For the purpose of drawing aquarium water through the windmill, there was positioned within container **6** a longitudinally extending, tubular aerating member **12**, the latter being secured to the upper wall **8** by means of the flange **14**. As best shown in Figure 1,

this aerating member **12** included a side arm **16** that projected outwardly through container **6** to receive an air hose **18** from an air pump (not shown) of conventional design. By this arrangement, air pumped into member **12** drew aquarium water into the lower end of member **12** in the direction of the arrows in Figure 3. In this way the partially aerated water was pulled through member **12** and sprayed through the exit **19** onto the driving and agitating member **30** for further aeration. The water withdrawn from container **6** and aerated as described was replaced by additional aquarium water drawn downwardly through the openings **10** and filtering material **7**, the thus filtered water then passed into the lower end of the aerating member and upwardly.

The air and water spray expelled through exit **19** of the aerating member **12** was used to actuate windmill blades **20** that in turn serve a number of purposes: they provided a device of pleasing appearance, they indicated whether or not the device was in operation and, if the aquarium water was sufficiently high, they served to agitate and circulate it. The device was provided with a windmill arm assembly **22** mounted on the upper wall of container **6**. This assembly **22** could be rigidly secured to the container if desired. Preferably, however, the assembly constituted a separate part of the device that simply was laid upon wall **8** so that the device could be readily disassembled. Accordingly, the assembly included a base member **24** of lead or other material sufficiently heavy to keep the assembly positioned on container **6**. This base member **24** was cut to receive flange **14** when positioned on container **6** so that the mixture of water and air expelled from aerating member **12** passes into the assembly for further aeration and to drive blades **20**.

As shown in Figures 2 and 3, the assembly **22** included a cap **26**, the upper end of which was provided with a plurality of openings **27** by means of which the mixture of water and air expelled from the aerating member **12** ultimately left the device. Cap **26** also had mounted therein a rotatable shaft **28**, one end of which extended outwardly beyond the lateral extremity of the cap to carry the windmill blades **20**.

Positioned within cap 26 and mounted for rotation on shaft 28 was a driving member 30 that, as shown in Figures I and 4, comprised a plurality of radially extending fins 32. As shown in Figure 1, driving and agitating member 30 was so positioned with respect to the exit end 19 of aerating member 12, that, as the mixture of air and water was expelled through exit 19, it struck the fin 32 adjacent thereto, thus causing member 30 and the windmill arms 20 to rotate, the air and water mixture thereafter passing upwardly into the cap where further aeration was effected and then out the openings 27.

Various modifications of the invention thus described could be made without in any way deviating from the inventive concept involved. For example, it was preferred that the device of the invention be made up of at least two parts to enable ready disassembly and cleaning, one part comprising the housing 6 with upper wall 8 and aerating member 12, and the other part comprising the windmill arm assembly 22. However, if desired, the device could be made as a unitary structure in which, for example, the housing bottom could be left open for the insertion of filtering material. Additionally, while the present invention had been illustrated by a windmill structure, the windmill arms could be replaced by equivalent means like a waterwheel, operated by the filtered and aerated water.

[Figure 167, *Design for an Aquarium, Number D125884*] Three fish globe design patents were assigned in this decade. The first was to Floyd J. Daughtry of Tyler, Texas in 1941, a multifaceted aquarium.

Figure 1 is a view in front elevation of the aquarium, Figure 2 is a vertical sectional view taken on the line 2 - 2 of Figure 1, Figure 3 is a horizontal sectional view on the line 3 - 3 of Figure 1, Figure 4 is a section taken on the line 4 - 4 of Figure 2 and Figure 5 is a top plan view.

[Figure 168, *Combined Holder and Receptacle therefor, or the Like, Number D136064*] The second was to Charles L. Fordyce of Brooklyn, New York in 1943 (a Teddy Bear holding a fish globe and

[Figure 169, *Fish Bowl, Number D136624*] The third was to Alexander F. Richards of Mayport Pennsylvania in 1943, a modernistic design with a triangular cross-section.

[Figure 170, *Combined Aquarium and Coffee Table, Number D148608*] The year 1948 was a bonanza year for table aquarium designs, featuring those by Alden D. Bullock of Seattle, Washington, an inverted dome.

[Figure 171, *Aquarium Table, Number D149043*] Lawrence A. Bouligny of Miami, Florida, a round table.

[Figure 172, *Aquarium Table, Number D149527*] and Judy Thomas of Los Angeles, California, rectangular. Since these table designs and the fish globe designs just mentioned were design patents, no information was given as to how these aquariums were to be maintained. This is especially unfortunate with the table designs, since these would require some clever engineering to supply concealed or otherwise unobtrusive filtration and aeration, and to provide for feeding and cleaning. The inventors simply glossed over these practical matters.

[Figure 173, *Pond and Fish Bowl, Number 2272582*] Alfred Poppe of Rochester, New York obtained a patent in 1942 for a toy house that combined a water wheel, a fish pond and a fish bowl. Water was lifted from the pond via the cups shown in Fig. 4 in the diagram to the top of the house where the water was released over the wheel, rotating it and aerating the water in the process (Fig 3. is the top plan of the house with its roof removed). Fig 1 is a front elevation of the house showing the fishpond extending out on the right side. The fishbowl (containing vertical slots, 42) was placed in the pond under the water wheel. The slots were located high enough so there was sufficient water in the fish bowl when it was removed to sustain the fish during the pond cleaning process. This was a very clever design for a novel aquarium that took into consideration the fact that aquariums do have to be cleaned regularly.

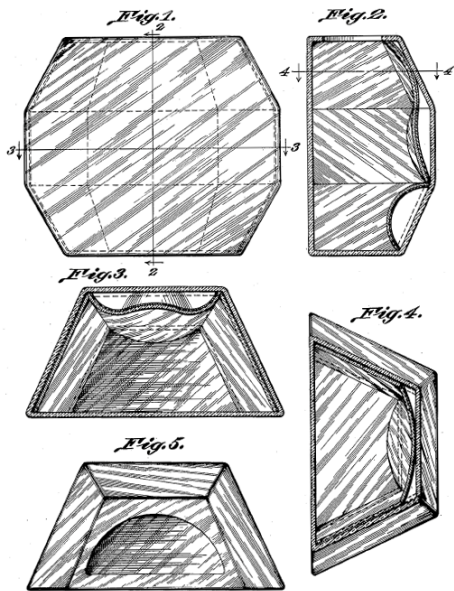

Figure 167: Floyd J. Daughtry's multifaceted aquarium, 1941.

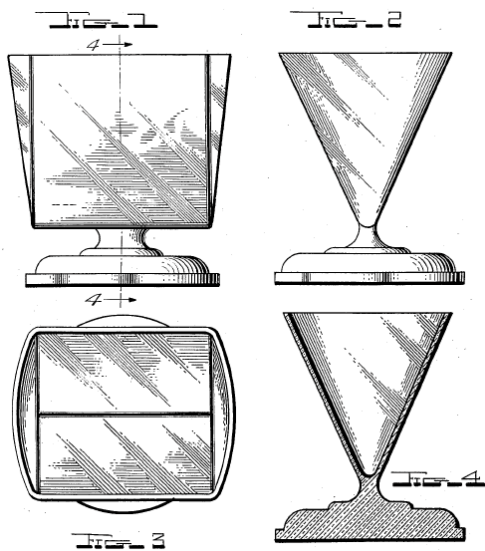

Figure 169: Alexander F. Richards' triangular aquarium, 1943.

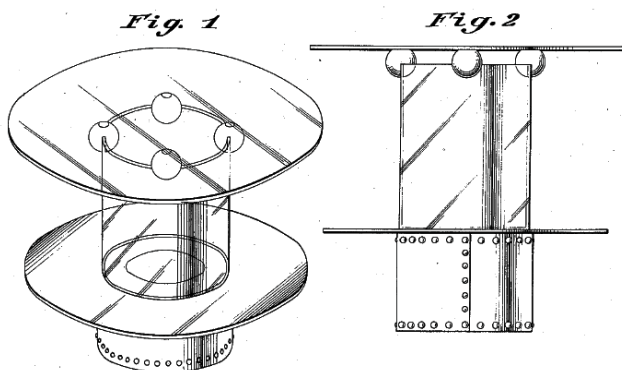

Figure 171: Lawrence A. Bouligny's table aquarium, 1948.

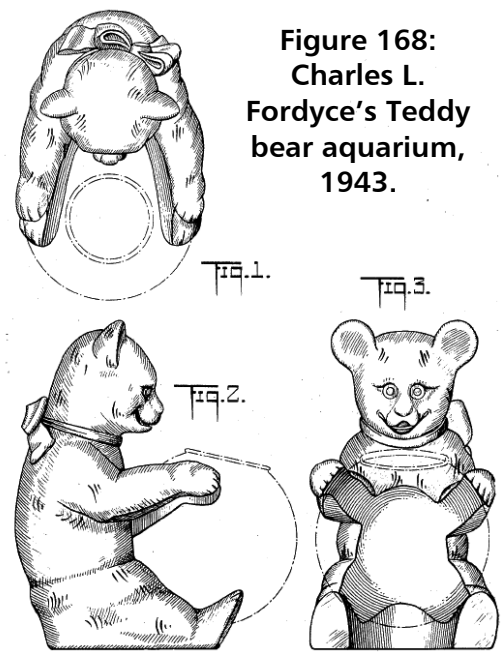

Figure 168: Charles L. Fordyce's Teddy bear aquarium, 1943.

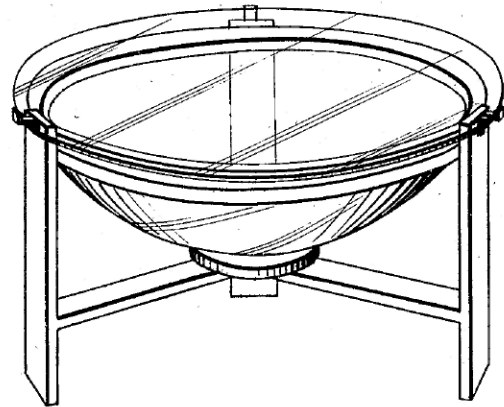

Figure 170: 1948: Alden D. Bullock's table aquarium, 1948.

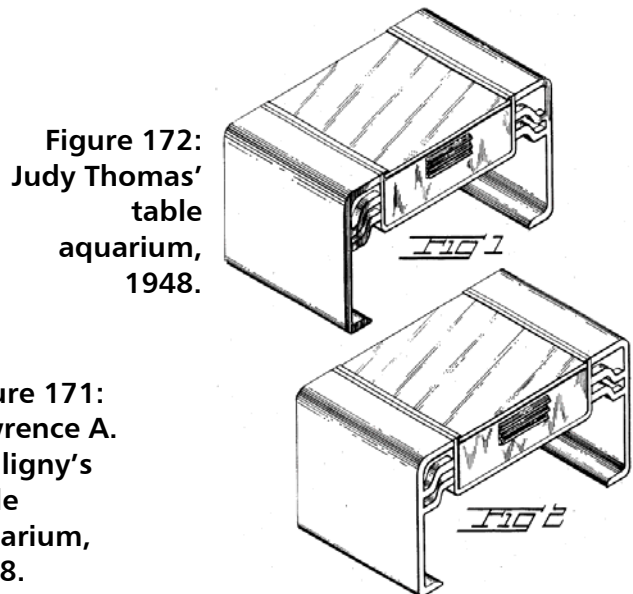

Figure 172: Judy Thomas' table aquarium, 1948.

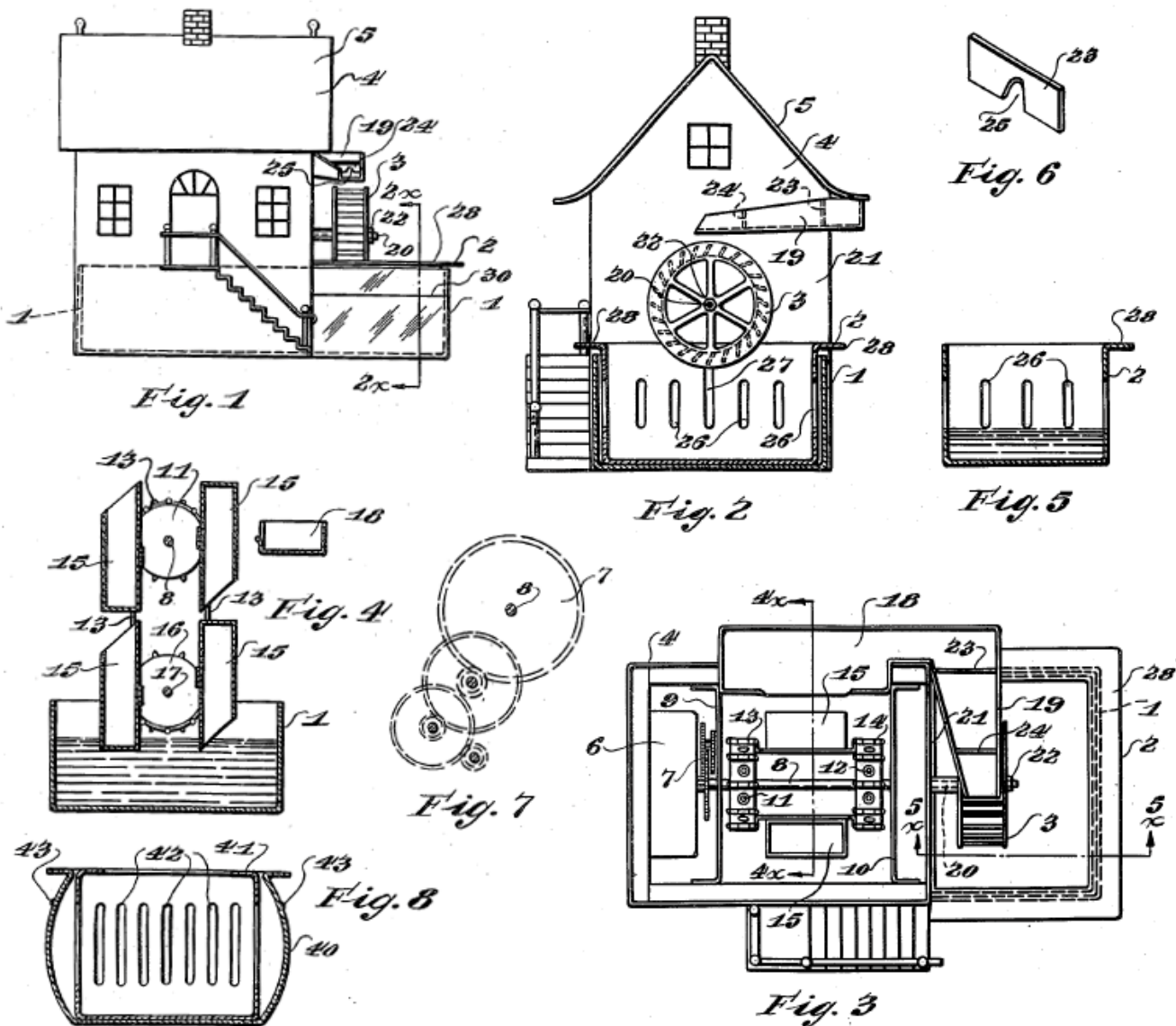

Figure 173: Alfred Poppe's toy house with water wheel design, 1942.

Figure 1 is a front elevation of the house with the fish-pond extending out on one side thereof; Figure 2 is a sectional elevation of the house, fish pond and fish bowl, the section being taken on the line 2x - 2x of Figure 1; Figure 3 is a top plan view of the house with the roof removed; Figure 4 is a section through the fish pond, elevator, and trough, the section being taken on the line 4x - 4x of Figure 3; Figure 5 is a section through the fish bowl, the section being taken on the line 5x - 5x of Figure 3, the bowl being shown removed from the fishpond; Figure 6 is a perspective view of a baffle plate used in the spout that feeds water to the water wheel; Figure 7 is a dia-

grammatic view of the reducing gear shown in Figure 3; Figure 8 is a sectional view through a modified form of the pond and fish-bowl.

In the drawings numeral 1 indicated the pond that extended through the whole basement of the house and projected outside of it on one end. 2 indicated the fish bowl that was inside of the pond and was placed outside of the house and under the water wheel 3. Both the pond 1 and the fish bowl 2 was preferably be made of glass and was separate structurally from the house. The house 4 sat down over the pond 1 and covered one end of it, leaving the oth-

er end projecting out from under the house. The house was covered by a roof 5 that was preferably separate from the house and could be removed from the house. Inside of the house was provided an electric motor 6 that drove through reducing gears 7 the shaft 8, which was mounted to turn in the channel plates 9 and 10. On this shaft was carried a pair of sprocket wheels 11 and 12 over which passed the endless chains 13 and 14. These endless chains carried the elevator cups 18, 15 of which four were shown In Figure 4. The endless chain ran under the sprocket wheels 16 on the shaft 17 all of which were driven idly thereby.

The motor drove the shaft 8 and this in turn drove the endless chains 13 and 14 and caused the elevator cups 15 to dip into the water in the pond 1 as they went down on the right in Figure 4. The cups were filled with water and raised the water on the left of Figure 4 and discharged it into the trough 18 shown on the right of Figure 4 near the top. The water ran along this trough into the spout 19 that discharged it onto the water wheel 3, and caused the water wheel to turn. The water wheel 3 was mounted on a stud 20 fastened in the wall 21 of the house. The water wheel was held on this stud by a nut 22. This nut could be removed so that the water wheel could be taken off. It was desirable to remove the water wheel in order to remove the fish bowl.

In the spout 19 was provided two baffle plates 23 and 24, each of which had its lower edge cut away to form an opening 26 therein such as is shown in Figure 6. The water was discharged by the elevator cups intermittently into the trough 18 and the baffles retarded the flow so that a fairly uniform stream of water ran out of the spout 19 and struck the water wheel 3. Before the trough 18 was emptied, it was filled again by another cup. In this way the water wheel was driven continuously at a fairly uniform angular velocity. The water was taken out of the pond inside of the house by the cups and discharged into the fish bowl on the outside of the house, and from the fish bowl it flowed through the upright slots 26 back into the fish pond, so that the same level was maintained in the bowl and pond.

In order to remove the bowl from the pond, the water wheel 3 was removed from its stud 20 and the fish bowl was raised up. To permit the bowl to be raised high enough, the bowl was provided with a special upright slot 27 that extended to the top and was open at the top. This slot straddled the stud 20 on which the water wheel revolved, so that the fish bowl could be raised higher than the pond, and it could then be removed from the pond. The pond could then be emptied, cleaned and filled with fresh water, the bowl put back in place and the water wheel remounted on its stud.

The slots 26 and 27 stop an inch or so short of the bottom of the fish bowl, so that a considerable quantity of the water was retained in the bowl in which the fish could live and swim for a short time, at least while the pond was being emptied and cleaned and filled with fresh water. The fish bowl was provided with flanges 28 on three sides thereof, which served as handles by which it could be raised. The flange on the side toward the house was omitted.

In Figure 8 was shown a modified form of the pond and the fishbowl in which combination the house and the apparatus that goes therewith was omitted. In Figure 8 there was provided merely a stationary pond 40 inside of which was a fish bowl 41 having the slots 42, 42 therein similar to the slots shown in Figure 5. It was apparent that the pond 40 held considerably more water than does the bowl 41. The bowl 41 could be lifted out of the pond, retaining the fish in the bowl, and then the bowl could be drained and cleaned and filled with fresh water. Thereafter the fish bowl 41 could be put back in the pond 40.

In Figure 11 was shown a water line 30 which indicated the height to which the pond should be filled so that it would not overflow when the fish bowl was put in. In Figure 8 was indicated a similar water line at 43 on the pond 40.

[Figure 174, *Hydrocultural Propagation, Number 2306027*] We leave this decade with a look at three decided oddities. The first was patented by Miller W. Swaney of Verona, New Jersey in 1942 and involved the simultaneous hydroculture of species of plants

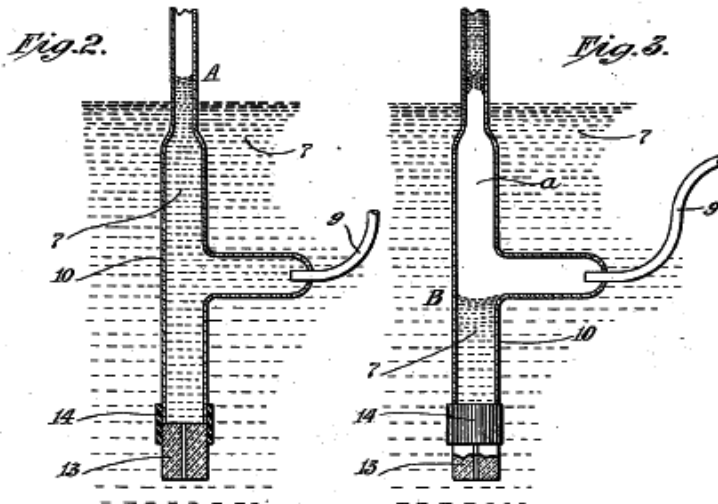
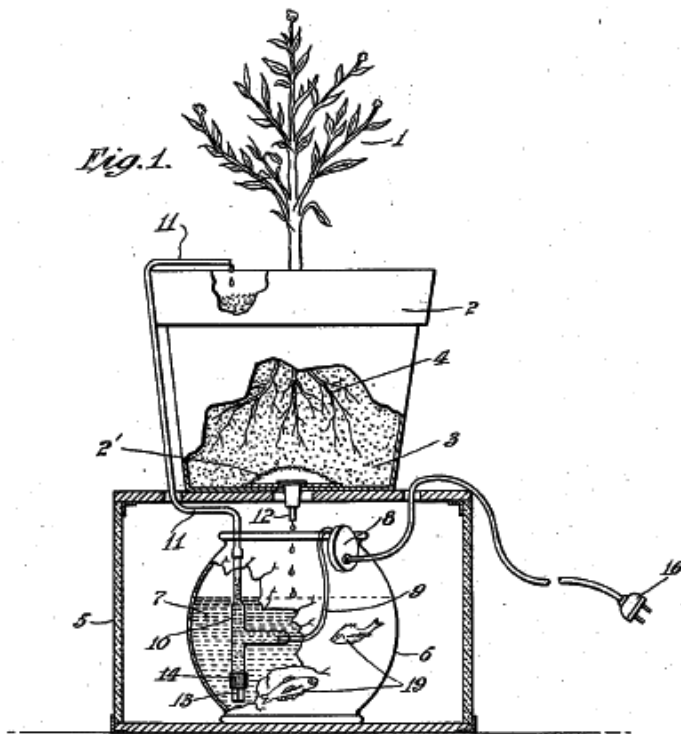

Figure 174: Miller W. Swaney's hydroculture aquarium, 1942.

and fish. Situated above an aquarium was a flower-pot, the plant in the pot being set in sand (there are two types of hydroponic plant culture: where the roots are in a liquid nutrient solution or in sand where a nutrient solution is allowed to flow over this aggregate). Water was raised from the aquarium to the flower pot via a small vibrator of the intermittent type, (8). The nutrient solution was placed directly into the aquarium where it was recycled into the flowerpot, the overflow returning to the aquarium via

the hole in the bottom of the pot. In addition to the inventor's nutrient solution (containing a complex mixture of salts that included sodium, potassium, and magnesium salts, with trace salts containing iron, manganese, copper, and zinc), further nutrients were provided by the fish. This would be an interesting experiment even today for any aquarist of an experimental bent!

Figure 1 represented a side view of the propagating means with cut away sections to more clearly show the important features of the apparatus, Figures 2 and 3 were views of the aerator in different stages of operation, Figure 2 being during the Intake cycle. By Intake was meant the period during which nutrient was being removed from reservoir into the aerator. The discharge period was that portion of the aeration and/or nutrient solution movement cycle when the nutrient solution was being removed from the aerator to the pipe or other conveying means that ultimately carried the nutrient solution to the plant and/or fish propagating portion of the apparatus.

In Figure 1, numeral 1 represented a plant growing in a plant propagating compartment filled with sand 3, the roots 4 being distributed throughout the sand. The compartment 2 rested on a box-like base 5 that housed a nutrient solution reservoir 6 partially filled with aqueous nutrient solution 7. Electrically operated aerator 9 was so constructed as to be able to send out a quick but moderate blast of air at intervals of every few seconds whenever plug 18 was attached to a source of electrical power. Thereafter the aerator momentarily shut itself off for 8 to 10 seconds, after which time the blast of air was then repeated, and so on (it was understood that the means by which this aerator was able to produce the succession of air blast was not a part of this invention). The gust of air traveled into T-tube 10 thereby causing nutrient solution inside 10 (see also Figures 2 and 3) to travel upward through delivery tube 11. The solution emerg-

ing from the upper end of **11** fell onto the upper surface of the sand **3** and then flowed by gravity over the sand and roots **4** and through screen **2'** and emerged from the bottom of the container **2** by means of the drain tube **12** and returned to bowl **8**. Thereafter the cycle was repeated over and over again. An additional step of the invention consisted of propagating fish **19** in the nutrient solution reservoir **8**. In this case, the box-like structure **5** and reservoir **6** could be made of transparent sides.

The specific mode of action of the solution transporting and aerating device shown enlarged in Figures 2 and 3 was as follows: In Figure 2 that shows the device immediately before operating, the T-tube **19** contained nutrient solution up to the level **A**. Just at the time of operation, air **a** or other "aerating gas" rushed in through tube **9** into T-tube **10** and exerted force on the nutrient solution in **19**. The solution was almost completely prohibited from leaving **10** through the lower end because of resistance to the rapid flow that was offered by capillary tube **13** that in turn was attached to T-tube **10** by connection **14**. Instead, the air pressure caused the solution in tube **10** to rise up through delivery tube **11** and flow onto sand **3** (Fig. 1). After the solution is elevated, the air blast ceased and the air pressure in **10** was decreased. Thus during the ensuing eight or ten seconds, solution **7** flowed into tube **10** through capillary **13**, pushing the air in tube **10** ahead of it and out through delivery tube **11**. The liquid level in T-tube **10** was thus raised from level **B** to level **A**. The apparatus then stood ready for another operation motivated by air entering through tube **9**. Thus was effected not only a continuous circulation of solution over the plant roots but also an efficient aeration of the solution as well. The gas used in causing solution to leave T-tube **10** by way of delivery tube **11** was hereinafter referred to as an aerating gas.

As a further phase of his invention, Swaney proposed to add goldfish, tropical fish and other small species directly to the nutrient solutions with which plants were to be propagated. He had made the unexpected discovery that goldfish and tropical fish, which are accustomed to existence in fresh water, live and thrive in nutrient plant-food solutions. He observed that these fish, which are generally maintained in fresh

water of pH near 7.0, i.e., an aqueous medium that was substantially neutral and therefore contains substantially no dissolved acidic or alkaline bodies, were capable of thriving even in very acidic nutrient solutions of pH as low as 4.0. Water exhibiting the latter pH values would contain an appreciable or substantial proportion of acidic bodies. Swaney found further that goldfish were capable of living in nutrient solutions containing dissolved copper and/or zinc (as their respective salts) in quantities generally conceded to be lethal to fish.

For example, It was known that rainbow trout were killed by a concentration of 1/2 part of hydrated cupric sulphate ($\text{CuSO}_4 \cdot \text{H}_2\text{O}$) in 1 million parts of water, or by a concentration of 2 to 5 parts of hydrated zinc sulphate ($\text{ZnSO}_4 \cdot 7\text{H}_2\text{O}$) in 1 million parts of water, or by a 1:100,000 concentration of an iron salt. Yet, Swaney found that goldfish thrived in nutrient solutions containing as much as 1-1/2 parts per million of hydrated copper sulphate and as great as 3 parts per million of mono-hydrated line sulphate ($\text{ZnSO}_4 \cdot \text{H}_2\text{O}$), in addition to a concentration of 1 part of hydrated ferrous sulphate ($\text{FeSO}_4 \cdot 7\text{H}_2\text{O}$) in only 25,000 parts of nutrient solution. Furthermore, a pH value of 4.4 was known to cause the death of carp within 5 days. Yet he observed that goldfish thrive in nutrient solutions of pH 4.0 even for a period of time as long as 10 days.

The following examples were experiments performed by Swaney:

Example 1. A granular nutrient mixture was prepared that contained the following salts in grams:

$\text{NH}_4\text{H}_2\text{PO}_4$ -----	128
NaNO_3 -----	400
KCl -----	224
$\text{CaSO}_4 \cdot 2\text{H}_2\text{O}$ -----	160
$\text{MgSO}_4 \cdot 2.7\text{H}_2\text{O}$ -----	192
$\text{FeSO}_4 \cdot 7\text{H}_2\text{O}$ -----	8
NaHSO_4 -----	2
H_3BO_3 (2 parts by weight); $\text{MnSO}_4 \cdot \text{H}_2\text{O}$ (2 parts by weight); $\text{ZnSO}_4 \cdot \text{H}_2\text{O}$ (2 parts by weight); $\text{CuSO}_4 \cdot 5\text{H}_2\text{O}$ (1 part by weight) --	
	3

This composition was so compounded that 7 grams (1 rounded teaspoonful) dissolved in one gallon water

gave a nutrient solution of the proper strength for normal plant growth.

Example 2. An apparatus of the type illustrated in Figure 1 was assembled using a flower pot (9-inch top diameter) filled with white quartz sand. The nutrient solution reservoir was a glass bowl of 1gallon capacity containing 3 quarts of nutrient solution prepared according to Example 1. In the sand were planted three dormant tubers of the white calla lily. The lead-in wires of the aerator were plugged into an electric line and the flow of nutrient solution was begun. After 15 days the tubers had rooted and sent up shoots several inches long. After 30 days (from planting) these shoots were about 1 foot in length. The nutrient solution was replaced by fresh solution at this stage. Forty-five days after planting, the calla stalks were about 1-1/2 feet in length and a number of large green leaves had unfurled. During the growth of these callas the solution was, at two-week intervals, replaced by fresh solution. Under this treatment, the callas continued to grow and thrive.

Example 3. Three goldfish, which were accustomed to existence in tap water of pH 8.4, were placed in a 4-gallon glass container filled with a full-strength nutrient solution prepared by dissolving 28 grams of the composition of Example 1 in 4 gallons of water of pH 8.4. The pH of the resulting nutrient solution was 5.4. The fish apparently suffered no ill effects but retained their appetites and vitality. They were kept in nutrient solution of this concentration for 25 days, the solution being replaced by a newly prepared one of the same concentration once each week (approximately) during this period.

Example 4. The three goldfish employed in Example 3 after remaining in the solution of Example 3 for 25 days, were transferred to nutrient solution of twice-normal strength. This was prepared by dissolving 56 grams of solid composition of Example 1 in 4 gallons of tap water of pH 8.4. The pH of the twice-normal nutrient solution was 4.4. In this solution the fish were kept for 22 days, during which entire time they suffered no harmful effects from the solution, and retained their appetites and vitality.

Example 5. A nutrient solution of three-times normal strength was prepared by dissolving 84 grams of the solid composition of Example 1 in 4 gallons of tap water of pH 8.4. The pH of the resulting solution was 4.0. The three goldfish were transferred from the twice-normal solution of Example 4 to the three-times normal strength solution, described in the preceding paragraph. They were kept in the latter solution for ten days, during which time they suffered no ill effects of the solution and retained their appetites and vitality. In this three-times normal strength solution copper and zinc, etc. were present in concentrations ordinarily sufficient to cause death. Yet in the presence of the other chemical salts comprising the nutrient solution, the fish tolerated these metals with apparent impunity. In actual concentrations, this nutrient solution contained 3 parts per million of $ZnSO_4 \cdot H_2O$, 3 parts per million of $MnSO_4 \cdot H_2O$, parts per million of $CuSO_4 \cdot 5H_2O$, and 1 part in 25,000 of $FeSO_4 \cdot 7H_2O$.

Example 6. Three tropical fish (1 male, 2 female guppies) were placed in an aqueous nutrient solution containing 7 grains of the composition of Example 1 dissolved in a gallon of water. The fish suffered no harmful effects and were in thriving condition even after 2-weeks immersion in this solution.

Example 7. Into a 5-gallon rectangular glass tank was placed 4 gallons of solution containing 28 grams of the composition of Example 1. Above this solution 3 small begonia and 2 small geranium plants (free of soil) were so suspended that only their roots dipped into the solution. In this nutrient solution were placed 2 goldfish. The plants grew very rapidly and blossomed profusely and the goldfish thrived splendidly. After each two-week period, the nutrient solution was completely replaced by fresh solution. After six weeks, the plants had increased in size several times and the goldfish were in excellent condition.

I have included this lengthy description of Swaney's work because this is the first time it has been reported in the aquarium literature.

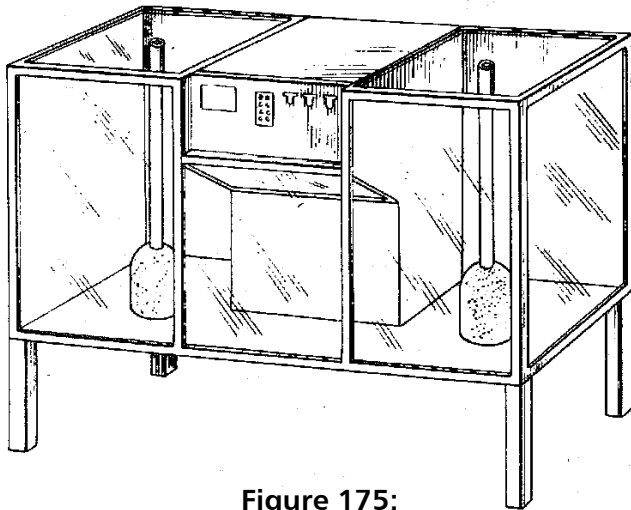

Figure 175:
Oliver Zenzen's radio aquarium, 1939.

[**Figure 175, Combined Aquarium and Radio Cabinet, Number D117704**] The last two of these odd contrivances involved radio aquariums. The first was a design patent by Oliver Zenzen of Washburn Illinois in 1939, so a description of how things worked is lacking.

[**Figure 176, Radio Cabinet, Number 2293612**] In 1942 a patent was awarded to Elwood J. Montague of Jamaica, New York for a radio aquarium that did provide considerable detail. The design was in the Art Deco mode and had a ship model on the top that was rocked by an electric motor to simulate the sailing of the ship. The tank was of triangular design in order to provide room for the radio equipment, but the interior of the cabinet had mirrors on both sides and the rear to impart an illusion of greater size. The controls for the radio were on the top of the cabinet and connected to it by a series of belts and pulleys. The tuning shaft belt actually rode around two shafts that were in the form of lighthouses. In fact, the radio could be tuned to the stations by rotating either of the lighthouses. The volume control knob, in addition to controlling the volume, was connected to a colored disk that rotated when the volume control knob was turned. A light was positioned below so that the colored light was reflected onto the surface of the aquarium. Two lamps were located in the two front hollow columns of the cabinets that also illuminated the aquarium (the ship was also illuminated). This was an exceedingly complicated design that would have required a great deal of skill and many labor hours to construct. Unfortu-

nately, there was also the matter of placing water near an electrical device.

Fig. 1 is a front elevation of a radio cabinet embodying the invention, Fig. 2 is a top plan view, Fig. 3 is a cross sectional view on the line 3 - 3 of Fig. 2, Fig. 4 is a view of the undersurface of the cover of the cabinet and of the adjacent portions of the inside of the cabinet, Fig. 5 is a longitudinal sectional view through one of the facsimile lighthouses on the line 5 - 5 of Figure 4, Fig. 6 is a sectional view in the direction of the arrows on the line 6 - 6 of Fig. 4 showing one of the lighting devices used in the invention, Fig. 7 is a sectional view in the direction of the arrows on the line 7 - 7 of Fig. 3 showing another one of the lighting devices used and Fig. 8 is a diagram showing the electrical circuits employed in connection with the invention.

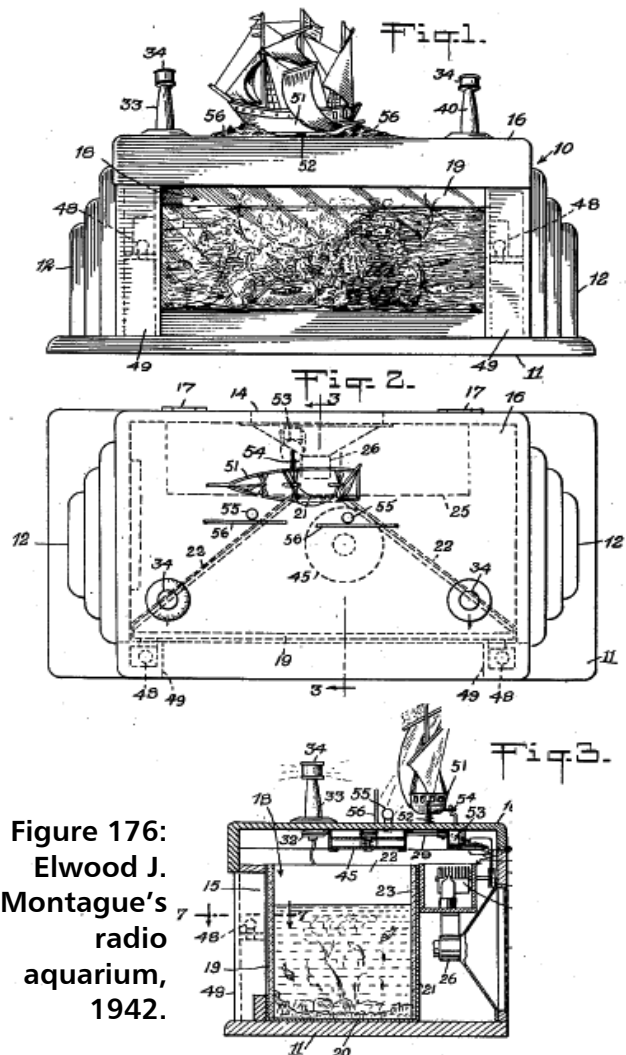

Figure 176:
Elwood J. Montague's radio aquarium, 1942.



THE HOBBY IN HIGH GEAR ONCE AGAIN: THE DECADE OF 1949-1958

[Figure 177, *Aquarium*, Number 2491853] This decade, the last to be discussed in this book, saw the resurgence of the number of aquarium patents issued. Three involved aeration, although the one by Louis Feldman of New York City in 1949 actually combined aeration, cleaning and filtration. Feldman arranged the gravel in his aquarium in a cascading manner, using a series of partitions that held the substrate in tiers. By doing this, sediment collected at the front of the tank. Located at the front of the aquarium was a U-shaped apparatus, the front of which was perforated by a series of holes. Air was supplied to the device by tube 26, connected to the tube 14 in Figure 1, forming an air lift that drew water that contained the sediment from in front of the device and transferred it to the filter located at the top of the tank at 16. Feldman's invention was an early form of simple multitasking.

Figure 1 is a perspective elevational view of the invention with certain parts omitted for clarity, Figure 2 is a transverse vertical section taken on the line 2 - 2 in Figure 1, Figure 3 is a horizontal transverse sectional view of the U-shaped device taken on the line 3 - 3 in Figure 1, Figure 4 is a view similar to Figure 3 and showing a slight modification of the device, Figure 5 is a detail view of the u-shaped device and Figure 6 is an elevational view showing two of the devices combined.

The numeral 10 indicated the container for the water, and 11 an aerator having the usual Intake of air 12 and outlet 13 in the water. A tube 14 had one end 15 bent and projecting into a strainer 40 and filter system 16, while the tube at its lower end was formed with a knee-bend 11 from which the tube 14 continued horizontally as indicated at 18. The portion 18 of the tube has a further bend 19 at the end thereof with

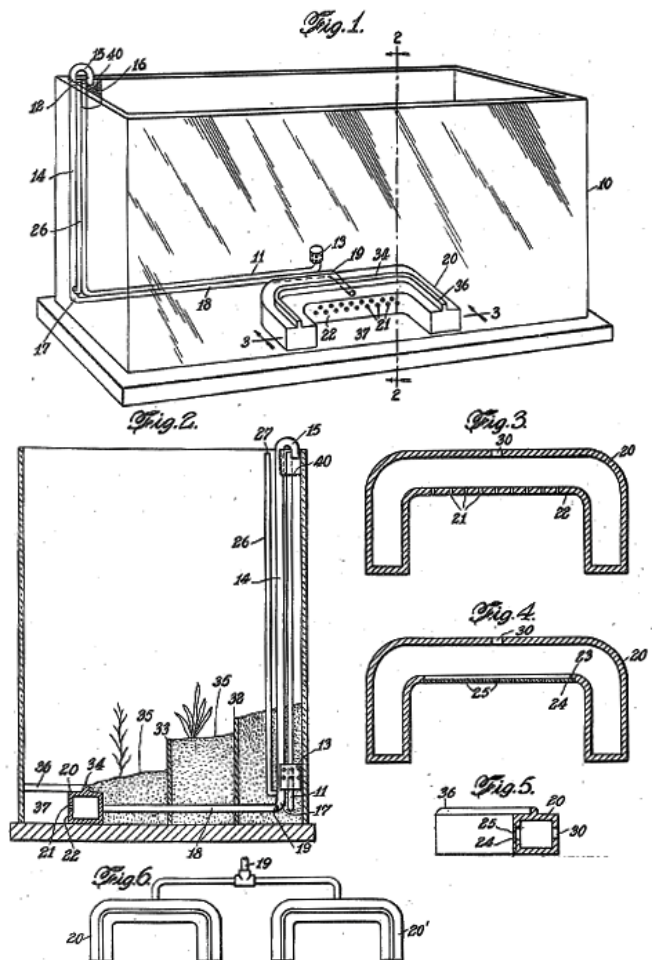

Figure 177: Louis Feldman's aeration, filtration, and cleaning design, 1949.

the latter projecting into a hollow, somewhat U-formed device 20 by means of a hole 30 in the latter.

This hollow device 20 was formed with a plurality of staggered perforations 21 upon its inner surface 22 and the lowermost of these perforations were a suitable distance above the bottom in order that they may not be clogged up by slime or dirt. Instead of the perforations 21 in the wall 20, the wall could be formed

with a cut-out 23 and a detachable strip 24, formed with perforations 25 therein and inserted into the cut-out as shown in Figures 4 and 5.

A tube 25 connected to an air pump (not shown) was connected to the tube 14 at about the knee-bend 17 in any suitable manner, so that air from the tube 26 could start a suction through the tube 14 from the perforations 21 or 25 respectively in the U-shaped member, and thus provided a steady flow of water mixed with impurities or dirt through the tube 14 to the strainer 40 and filter 16.

The bottom or terrain of the container were formed with set-offs 32 and 33 so as to substantially prevent the gravel 35 from overflowing and covering the device 20. The latter was, in turn, provided with a rim 34 terminating in extensions 36 at substantially right

angles to the latter to further assure that no gravel passed over the U- shaped device, which was positioned close to the wall of the container, and would always have a clear space 37 in front of the apertures 21 or 25. In Figure 6 the construction is as before described, the only difference being that two devices, 20 and 20' were connected to the tube 19' in any convenient manner.

[Figure 178, *Aerator*, Number 2772867] In 1956 Howard R. Cleckner of Tipp City, Ohio was assigned a patent for an aeration device. Tap water entered at 26 on the right side of Fig. 1 in the diagram, drawing air with it from holes (30) in the conduit. On the left side is a discharge tube (C) with a hole in its top that prevented siphoning of the water when the level dropped below the lowest hold in the conduit. Cleckner's patent showed a number of variations on

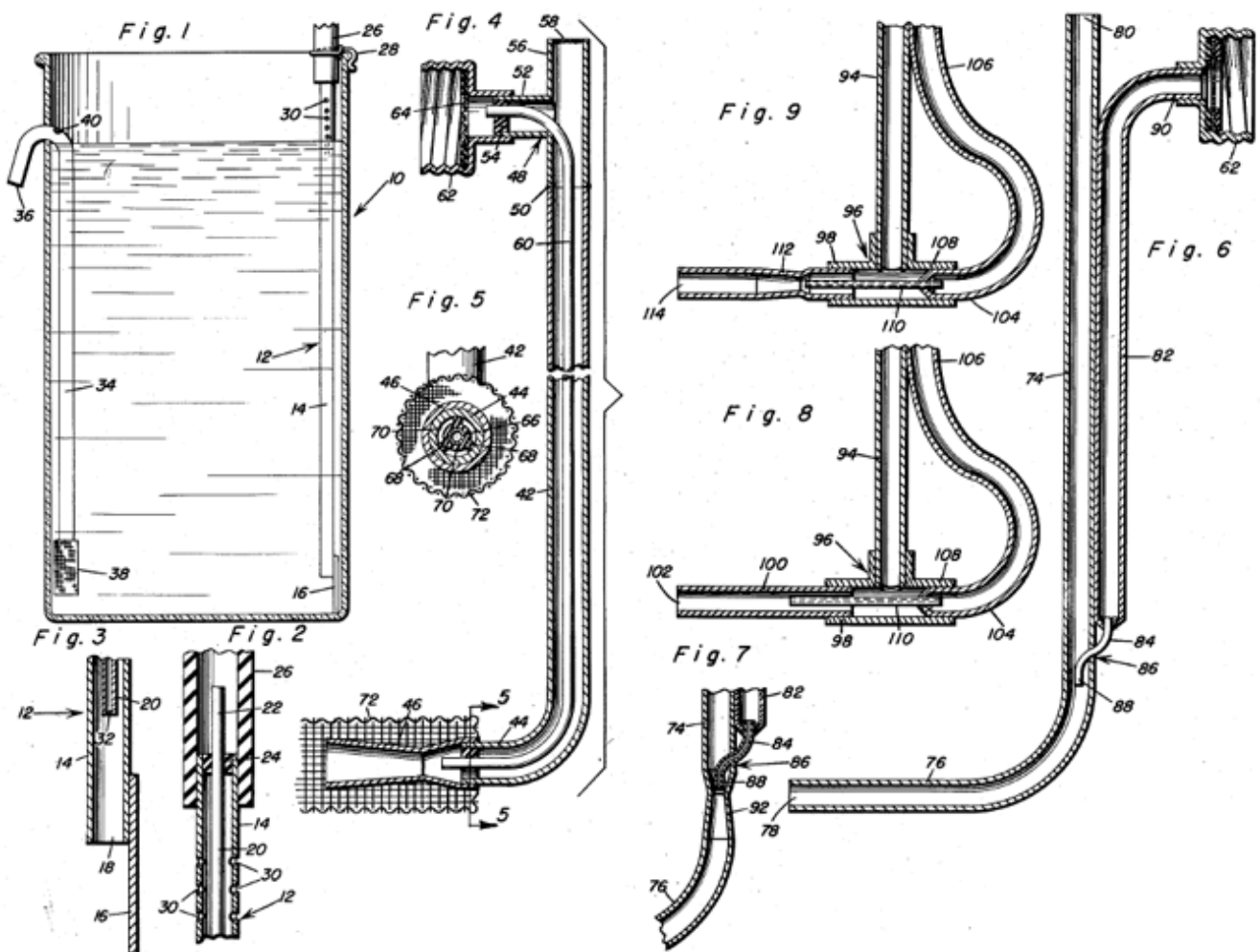

Figure 178: Howard R. Cleckner's aerator, 1956.

the design of the aerator that improved its efficiency, but the result was the same regardless of which variation was used. It is interesting to note that the inventor cited six previous patents that had a bearing on his design that involved absorbers, wash tanks, de-gasifiers, flush tanks and bath sprays, attesting to the fact that many of our aquarium devices had their genesis in equipment that had nothing to do with the aquarium.

Figure 1 is a vertical section taken through an aquarium, fish tank or the like showing the aerator mounted therein; Figure 2 is an enlarged vertical section taken through the upper end of the aerator; Figure 3 is another enlarged vertical section taken through the lower end of the aerator;

Figure 4 is an enlarged vertical section taken through a modified form of aerator and showing details of its internal construction; Figure 5 is a vertical section taken substantially along the plane of section line 5 - 5 of Figure 4 and showing the lower end construction of the aerator; Figure 6 is an enlarged vertical section taken through a still further modified form of the aerator and Figures 7, 8 and 9 are enlarged vertical sections taken through the lower ends of still further modified forms of the aerator.

Reference numeral **10** indicated generally an aquarium, fish or bait tank that was partially filled with water within which any desired type of marine life could live. With reference to Figures 2 and 3 in addition to Figure 1, reference numeral **12** indicated generally an air conduit that comprised a vertical tube **14** whose lower end, Figure 3, was provided with a rod-like extension **16** secured thereto to maintain the open end **18** thereof in spaced relation with respect to the bottom of the fish tank or other receptacle within which the aerator was to be used. A second or water conduit **20**, of tubular configuration, was disposed concentrically within the first conduit and its upper end **22** (see Figure 2) extended outwardly of the first conduit. Adjacent the upper end of tube **14** was an annular washer or seal **24** through which the water conduit **20** extended and this seal not only prevented water from being discharged into the upper end of the tube **14**, but also maintained the tube **20** in proper concentric relation within the first conduit.

This seal could be formed of rubber or other resilient material to provide an effective seal.

The upper end of the first conduit also carried one end of a resilient tube or hose **26** that was frictionally engaged thereon, the other end of which was adapted to be inserted over a faucet or other water outlet opening so as to supply water under pressure to the inner or second conduit **20**. A wire hook or the like **28** could be provided on the hose for maintaining the aerator in proper position on the tank or receptacle. The upper wall of the air conduit **14** was provided with a plurality of air intake apertures **30**. When tap water was discharged through the free end opening **32** of the water conduit, a portion of its kinetic energy would be converted within the lower end of the air conduit to draw air downwardly through the openings **30** to be mixed with the discharged tap water and entrained therein so that the lower end opening **18** of the air conduit presented a discharge opening for aerated water and free air bubbles.

To maintain a constant level of water within the fish tank or other receptacle within which the aerator was to be used, a discharge tube **34** was disposed within the tank, and its upper free end was provided with a discharge opening, as at **36**, while the lower end thereof was provided with a filter screen **38**. A vent opening **40** was provided adjacent the looped upper end of the discharge tube to prevent siphoning action by the discharge tube.

In Figures 4 and 5, there was shown a modified form of aerator in which the air conduit comprised a vertical tube **42** having a right angular lower end **44** that terminated in a venturi tube **46** secured thereto. A T-shaped coupling member **48** was suitably secured, as at **50**, to the upper end of the vertical tube **42** and the horizontal branch **52** thereof provided with a resilient seal **54** similar to the previously described seal **24**. The upper branch **56** of the coupling presented an air intake opening that could be conveniently covered by a filtering screen **58** if so desired. Water conduit **60** extended through the seal **54** and concentrically within the air conduit in order to supply water under pressure thereto. A female coupling member **62** was secured to the free end of horizontal branch

52, a screen element 64 being conveniently placed therein for the purpose of filtering the tap water.

The lower end of the water tube was provided with an annular ring 66 having radially extending fingers 68 thereon that presented openings 70 for the free passage of air, the ring and fingers serving to support the free lower end of the water conduit. When water was discharged therefrom into the throat of venturi tube 46, the ensuing conversion or energy would draw air down through the air tube to be mixed and entrained within the water so that the free end of the venturi tube presented a discharge opening for aerated water. The lower end of the air conduit could be provided with a cylindrical screening member 72 for the purpose of preventing foreign material from entering the bait tank and for breaking up larger bubbles of air in the discharged water.

Figure 6 shows a further modification of the aerator in which the same principles as set forth above were involved but in which the specific disposition of elements differs from the devices previously described. In this form, the air conduit comprised a vertical tubular portion 74 having a lower right angular portion 76 presenting a discharge opening 78 for the aerated water, the upper end opening 80 being provided for the reception of intake air. The water conduit 82 was secured in juxtaposed relation to the air conduit and was provided at its lower end with a substantially S-shaped tubular member 84 that extends through the wall of the air conduit, as at 86, to present a water discharge end 88 within the air conduit. The upper end of conduit 82 was provided with a laterally offset portion 90 that had secured at its free end a female coupling element 62. The operation of this modification was identical to that previously described, the tap water being discharged from the tubular member 84 within the air conduit to thereby entrain air therein so that aerated water would be discharged out of the opening 78.

Figure 7 was a modification of the device shown in Figure 6 in that the lower end portion of the air conduit was deformed to present a venturi tube 92 into the throat of which the S-shaped tube 84 discharged. In Figure 9, a further modification of the general

structure shown in Figure 8 was shown in which the air conduit comprised a vertical tube 94 having its lower end formed as a T-shaped coupling element 96, one horizontal branch 98 of which carried a horizontal tube 190 presenting a discharge opening 192 for aerated water. The lower end 104 of water conduit 106 was received in the other horizontal branch 108 and was provided with a discharge tube 110 that extended to a point within the horizontal tube 100. In Figure 9, the construction was identical to the form shown in Figure 8 with the exception that the horizontal tube was shaped in the form of a venturi 112 into the throat of which the horizontal discharge tube 110 discharged. The venturi member was provided at its free end with an opening 114 for the discharge of aerated water.

The forms of the invention shown in Figures 4-9 were particularly adapted for use out of doors wherein the female coupling member 62 presented a convenient means for the attachment of a garden hose, the form shown in Figure 1 being more particularly adapted for use indoors wherein the hose 26 could be slipped over the end of a faucet or the like. In all of the forms, the operation was essentially the same, i.e., the kinetic energy of a moving mass of water being utilized to entrap and entrain air therein to condition it prior to its discharge within the confines of a receptacle to be used for maintaining marine life therein. It will be noted that the agitating effect of free air escaping to the surface of the water expedited the process of removing carbon dioxide that normally took place only at the surface. By discharging aerated water and free air near the bottom of the tank, the removal took place not only at the surface but throughout the entire tank. In many places it could be advantageous to use a small circulating pump to move the water from the tank, through the aerator and back into the tank forming a closed system. This system was desirable in those instances where tap water would be too cold to support the marine life under consideration.

[Figure 179, *Aquarium Aerator*, Number 2824728] In 1958 Herbert C. Crawford created an aerator that required no air or water supply whatsoever. This strange device consisted of a number of

round sections in layers that had pockets designed to hold air (Fig. 3 shows a detail of the pockets and Fig 4 shows a bottom view of one of the section members of the aerator). The aerator, made of aluminum, plastic, or stainless steel, was first gently lowered into the aquarium, trapping air in the pockets and then fastened at the bottom of the aquarium by a hook embedded in a suction cup. Over time, the oxygen would in theory dissolve into the water, leaving the nitrogen behind. After an interval (the inventor did not specify its length) the device was removed, releasing the depleted gas, and then reinserted into the aquarium for the process to begin anew. Although theoretically feasible, this is another Rube Goldberg device. Not only would the aerator be an eyesore in the tank, not enough oxygen would be absorbed into the water in any reasonable amount of time to make it worthwhile.

Fig. 1 is a perspective view of the invention with parts broken away to illustrate the hook engaging the eye of the center rod, Fig. 2 is a cross-sectional view taken on a line 2 - 2 in Fig. 1, Fig. 3 is an enlarged fragmentary view particularly illustrating the air pocketed in the cells by the water and Fig. 4 is a bottom view of one of the section members of the aerator.

1 designated an aerator embodying the features of the intention adapted to be installed in an aquarium having a bottom 2 as illustrated in Fig. 2. The aerator included a rod 3 having an eye 4 on the bottom thereof adapted to be engaged by a hook 5 on a suction cup or the like 6 that engaged the bottom 2 of the aquarium in which there was usually a layer of sand or other material as indicated at 7 (Fig. 2). The eye 4 could be formed by providing the lower end of the rod 3 with an opening or by beading the lower end upwardly and inwardly to form the eye 4.

Adapted to engage vertically on the rod 3 was a plurality of section members 8 having a plane top surface 9 and having a depending flange 10 and a plurality of transverse cross flanges or partitions 11 forming pockets or cells 12 on the underneath side of the section members. Each section member was provided at substantially the center thereof with an opening 13. Surrounding the opening and integrally formed therewith was a tubular member 14 forming a tubular boss 15 having notches 16 and 17 in the respective sides thereof to provide a spring tension on the rod 3 when the members were placed on the

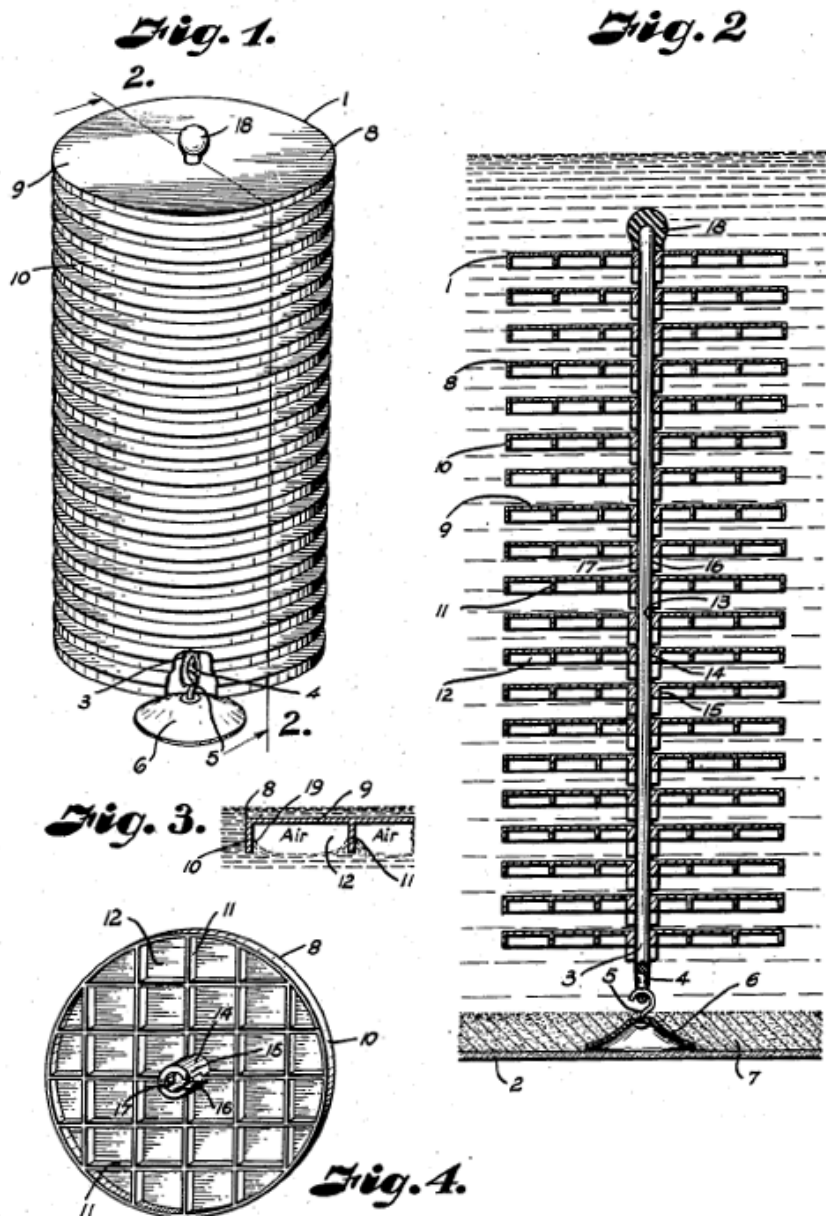

Figure 179: Herbert C. Crawford's aerator, 1958.

rod for adjusting the sections vertically on the rod **3** and retaining them in place thereon. A removable knob **18** was placed over the upper end of the rod **3** above the uppermost section member **8** to serve as an ornament and grip for removing the aerator from the aquarium.

The size of each cell or pocket **12** was of importance. The lateral dimension of each cell had to be just small enough to allow the adhesion of water to the partitions to make the air relatively immovable to small changes of direction of force of gravity in relation to the aerator units or sections **8**. The depth of the partitions was to prevent air from spilling out of the pockets and to add more air surface to the water because of curvature made by adhesion of water to the partition, as illustrated in Fig. 3. The aerator had to be removed from the water periodically to allow fresh air to enter into the cells or pockets **12**. The aerator was of light weight and buoyant so that it would stay afloat for a substantial length of time. The oxygen in the air would be dissolved fairly rapidly; however, the nitrogen would be dissolved very slowly. The more surface for the adhesion of the water the more oxygen would be maintained in the pockets.

Figure 3 illustrated the action of the water in the cells. The water moved upwardly along the edge of the depending partitions as indicated at **19** while the water at the center of the cell remained at a level substantially equal to that on the outside of the aerator, thus providing more adherence of the water to the aerator.

[Figure 180, *Device for Aquariums or the Like*, Number 2847973] On the lighter side of aeration, Joe S. Pugh of Hamilton, Texas patented an ornamental aerator in 1958 that provided a

color light show as well. The aerator was constructed in a spiral shape with an entry for water located at the bottom of the spiral. The bubbles of air followed this merry path, and when the three colored lights located in a box at one end of the aquarium struck the spiral, it produced a riot of colors. The air bubbles at the surface of the water also acted as reflectors, thus enhancing the effect.

Figure 1 is a perspective view of the ornamental device in position in an aquarium, which is partly broken away, and showing the light producing means suspended on one wall of the aquarium; Figure 2 is a perspective enlarged view of the ornamental device; Figure 3 is an enlarged perspective view of the internal components of the light producing means and Figure 4 is a front view of the light producing means.

The ornamental device **10** included a substantially dome shaped opaque base **12** to which was secured, by clips **13**, a transparent tube **14** that ascended gradually in any desired manner as in the spiral manner shown, upwardly from its lower end **15** to its upper end **16**. A flexible tubing **17** had one end connected to the outlet of a needle valve **18** and extended

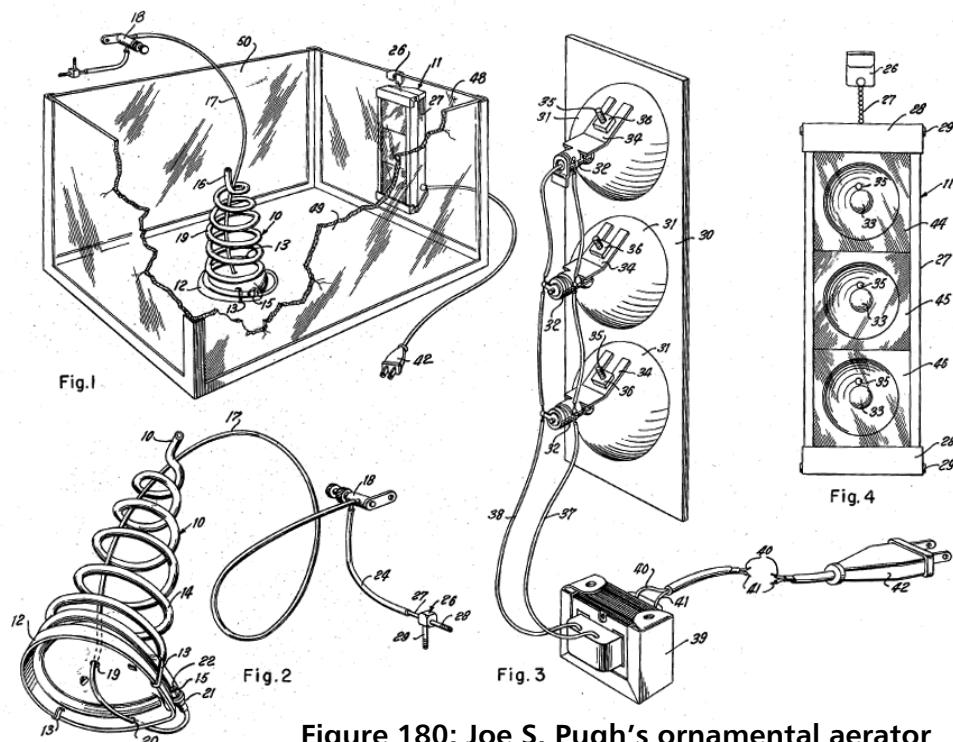

Figure 180: Joe S. Pugh's ornamental aerator and light show, 1980.

through the coils of the tube **14** and the apertures **19** and **20** of the base into a fitting **21** that connected the lower end of the flexible tubing to the lower end of the tube **14**. The fitting **21** was preferably of rubber or other similar resilient substance and had a groove **22** in the outer surface thereof that admitted water from the aquarium into the lower end of the tube **14**. The upper end **16** of the tube **14** could extend above the surface of the water in the aquarium although the device would function just as well if the upper end was also submerged.

The inlet of the valve **18** was connected to a suitable source of air under pressure, such as a conventional electrically driven pump, not shown, through a conduit **24**. The inlet end of the conduit **24** could be connected to one outlet **25** of the usual T-fitting **26**. Any other desired aquarium device, such as a filter, could be connected to the other outlet **28** of the T-fitting. The inlet **29** of the fitting was connected to a pump or other source of air under pressure.

The valve **18** was adjusted to permit air at a predetermined desired rate to flow through the tubing **17** into the lower end of the tube **14** where it produced bubbles of air in the tube **14**, which ascended upwardly in the tube. Water that entered into the lower end of the tube **14** through the groove **22** of the fitting was moved upwardly between the bubbles of air and was expelled from the upper end **16** of the tube to flow back into the aquarium. The water so exposed to air in the tube absorbed oxygen from the air bubbles and thus the device **10** not only served as an ornamental device but also as an aerator. An optimum amount of oxygen was absorbed from the air in the bubbles since the rate of movement of the bubbles was slowed by the friction between the moving water and the inner walls of the tube. Moreover, the path through which the water and the bubbles of air must move in the tube was much greater than the straight upward path taken by air bubbles freely escaping at the bottom of an aquarium from a conventional aerator.

In addition, if the end **16** of the tube was above the top surface of the water in the aquarium, the water moved upward by the air bubbles was thrown into

the air at the upper end and was thus further exposed to air. Accordingly, the air moving upwardly in bubbles through the tube was held in contact with water carried upwardly between air bubbles for a long time due to the slowed rate of movement of the air bubbles and the long path that they must travel so that an optimum amount of oxygen was absorbed from the air by the water which then absorbed still more oxygen from the air above the water upon being expelled from the lower end of the tube. Water from the lower end of the aquarium, which has a relatively small amount of oxygen, was moved upwardly through the aerator between the bubbles so that a vertical circulation of water within the aquarium results providing properly oxygenated water at all levels of the aquarium.

The bubbles of air in the tube were visible to an observer since the tube **14** was made of glass, plastic or other variable transparent substance. When viewed under ordinary white light, the air bubbles, of course, were colorless and did not produce any color effect. In order to provide a moving multicolored effect in the aquarium, the light producing device **11** was suspended by means of the hook **26** from the end of the aquarium. The light producing means comprised a housing **27** provided at its ends with caps **28** secured thereto by screws **29**. A vertical plate **30** disposed in the housing **29** had three concave portions **31** having central apertures through which extended rearward the ends **32** of light bulbs or lamps **33** which were placed in the concave portions of the plate. The ends of the bulbs were held by clips **34** secured to the concave portions by screws **35** and nuts **36**.

The bulbs **33** were connected in parallel across the output leads **37** and **38** of a voltage reducing transformer **39** whose input leads **40** and **41** terminated in a conventional plug **42** which could be connected in any conventional outlet. The transformer **39** was arranged in the housing behind the plate **30** and rested on the bottom cap **28**. Situated in the housing outwardly of the plate **30** and in front of the bulbs **33** were three colored glass plates **44**, **45** and **46**, each differing in colors from the others. For example, the top glass plate **44** could be blue, the middle glass plate **43** could be red and the bottom glass plate **46**

could be green. The glass plates preferably had one of the primary colors, i.e., red, blue, green or yellow.

In use, the light passed through each of the glass plates was of a particular color and was projected through the glass end wall **48** of the aquarium into the aquarium and out of the tube **14**. The water surfaces about and defining the air bubbles acted as reflectors reflecting the multicolored light projected into the aquarium by the device **11** toward the observer through the front and rear sides **49** and **50** of the aquarium. Since the bubbles were constantly moving, the varied colored light reflected toward the observer constantly moved and shifted the colors, shifting and blending in the process so that the total effect was pleasing and intriguing to the observer. The housing **29** hid the bulbs **33** from the view of an observer in front of the aquarium so that the observer saw the light emitted by these bulbs only as it was reflected by the water surfaces of the air bubbles as they rose through the tube, although some could also be reflected off the tube itself.

It had been discovered that aquariums must be lighted from above, for white light projected horizontally through the sides of the aquarium or through the bottom thereof had a deleterious effect upon fish which was known as swim bladder imbalance and therefore side lighting of aquariums has in the past proven unsuccessful. The light producing device **11**, however, projected colored light, preferably a plurality of primary colors, and such colored light has proven to have no such harmful effect upon the fish.

The ornamental device **10** can be made of a closed hollow transparent tube, in which case it does not function as an aerator and then served merely as a reflector of the colored light. If desired, no reflector of any kind need be placed in the aquarium, the fish and vegetation serving as the reflectors of the colored light. The fish tended to reflect a spectrum, as in a rainbow, when further removed from the light producing means **11** and reflecting a single projected color when near the means **11**. For example, when near the blue colored

plate **44** near the top of the aquarium, the fish would reflect a blue light and appear blue; when it descends near the red colored plate **45** it would reflect a red light, and when it descended still lower near the green colored plate **45** it would reflect a green light.

If desired, two light producing means **11** could be used projecting light from both ends of the aquarium, or a reflector, such as aluminum foil could be secured to rise end of the aquarium opposite the end **48** to reflect the colored light for the means **11** back into the aquarium. An ordinary aerator could also be used which merely released bubbles of air that ascended upwardly and freely through the water in the aquarium. Such bubbles of air would also appear to be multicolored although the effect was not as vivid or as pleasing as when the device **10** was employed as an aerator. If desired, the light emitting means **11** could be sealed against water and could then be placed within the aquarium to project light through the water although the location of the means **11** shown in Figure I was preferred.

[Figure 181, *Aquarium Cleaning Device*, Number 2672987] Clyde E. Hutchinson of Venice, California invented a cleaning device on 1954 that – variations thereof – are still used today. It was designed to manually remove the sediment from the bottom of an

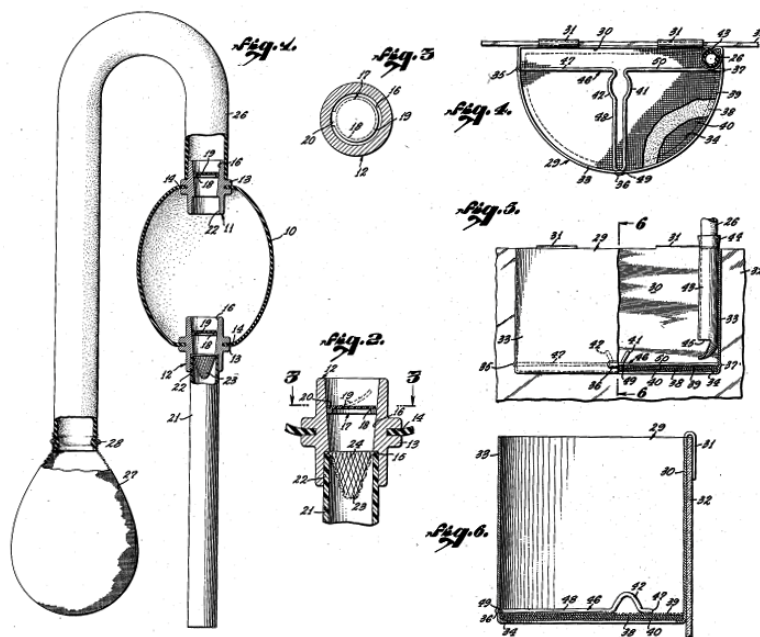

Figure 181: Clyde E. Hutchinson's cleaning device, 1954.

aquarium by sucking water up through a tube via a suction bulb (A) at the other end. Near the aquarium end of the tube was a large bulb (B) that contained a check valve to prevent large particles – such as gravel – from entering the device and clogging it. The outlet portion contained a filter that prevented sediment from passing through. The dirty water collected in bulb B where it could be discarded or else put through the strainer shown in Fig. 4 to return clean water to the tank. It was a very simple device, but effective.

Figure 1 is a general view of the aquarium cleaning device with parts shown in section; Figure: 2 is a fragmentary longitudinal cross section through the valve structure shown partly in section in Figure 1, the figure being drawn on a larger scale; Figure 3 is a cross-section on the line 3 - 3 of Figure 2; Figure 4 is a front elevation of a modified form of strainer for the water sucked up from the tank and discharged there into by the device; Figure 5 is a plan view of the strainer shown in Figure 4 and Figure 6 is a section taken along line 6 - 6 of Figure 5.

Referring now to Figure 1, the cleaning-device of the invention comprised a bulb of resilient rubber providing a collapsible chamber the bulb being alternately manually squeezed to reduce the volume of the chamber and allowed to regain its original volume due to the resiliency of the rubber walls. The bulb 10 was formed with two openings, the defining edge of each being engaged in valve housing and tube connector means 11 and 12. The valve housings were identical in form, each comprising a rigid body member of tubular form having intermediate the ends thereof an outwardly projecting annular flange 13. The flange 13 of each housing was provided with a groove 14 sufficiently deep and of a configuration to form a substantially liquid tight seal with the defining edge of the opening in the bulb in which the valve housing was inserted.

The diameter of the bore of each of the valve housings 11 and 12 was increased for a short distance inwardly from one end to provide a shoulder 15 at the inner end of the increased diameter bore. The remainder of the bore of the valve housing was given

a slight outward taper from the portion of least inside diameter toward the opposite end of the housing, as indicated at 16, for ease of assembly.

The valve structure 17 comprised an annular seat 18, the outer periphery of which was preferably tapered to fit the tapered portion 16 of the bore of the valve housing. The outer diameter of the seat was less than that of the wider end of the tapered bore and greater than that of the narrower end of the tapered bore so that a seat could be securely jammed in position in the tapered portion of the bore in each valve housing. The wider end of the tapered portion of the bore of the valve housing 12 was directed toward the inside of the bulb. The wider end of the tapered portion of the bore of the valve housing 11, on the other hand, was directed away from the bulb 10.

The non-return valves were formed of discs 19 of thin resilient material such as a suitable plastic. At one point they were provided with a radially projecting tab 20 that was secured by a suitable bonding material to the wide face of the seat 18 as shown in Figure 3. The disc 19 was of slightly less diameter than the outer diameter of the seat so that in response to flow in one direction it could deflect upwardly from the tab 20 but yet would securely engage the seat to close the passage there through to prevent flow in the reverse direction. A suction tube 21 was formed from a piece of tubing of a rigid material such as plastic and could be merely pressed into the cylindrical portion 22 of the bore of the valve housing 12.

In order to prevent snails, small pebbles or relatively large pieces of debris such as small dead fish, from being sucked into and perhaps jamming the suction valve carried by the housing 12, or if drawn into the bulb 10 from jamming the non-return valve of the housing 11, the inventor preferred to use a relatively coarse mesh filter 23 ahead of the suction valve. As shown in Figure 2, the filter 23 was formed of a relatively large mesh wire screen 24 of cone shape, the base of which was secured to a ring 25 or flared outwardly to form an annular mounting member that was clamped between the end of the tube 21 and the shoulder 15 of the valve housing 12.

The delivery or return tube **26** was formed from a length of flexible tubing telescopically fitted over the outwardly projecting portion of the valve housing **11**. The opposite end of the tube **25** was fitted with fine filtering means that could consist of a strainer **27** of fine wire mesh or a fabric, such as cotton cloth, formed as a small bag, the neck of which could be secured to the tube **26** by some clamping means such as a length of string **28** or a tightly stretched rubber band. By untying the string or working the rubber band off the end of the tube **28**, the strainer **27** could be removed, turned inside out and washed clean. The strainer could be, and usually was, left in the water of the aquarium while the dirty water sucked into the bulb was discharged again into the water in the aquarium, freed from the suspended dirt that was retained in the strainer **27**.

The modified form of strainer unit shown in Figures 4, 5 and 6 was designed to be suspended on the wall of an aquarium and could be left in position when not in use, thus avoiding having to dry and store the fabric type of strainer. The strainer unit **29** consisted of a metal or plastic shell semicircular in plan view as shown in Figure 5. The straight or back wall **30** could be provided with a pair of bent over clips **31** soldered or otherwise secured to the back wall and adapted to be supported on the wall **32** of an aquarium. The bottom edge of the back wall **30** and front wall **33** were, in the illustrations, inwardly turned to provide an inwardly projecting peripheral flange **34**, but the bottom of the shell was open otherwise. At points **35**, **36**, and **37** spaced around the shell at a predetermined distance above the bottom edge thereof, outwardly directed depressions were formed of generally semi-spherical shape and of small radius.

A filter unit was cut closely in the bottom of the shell of the strainer and, as shown in Figure 6, was formed of an integrated pad of felted fibers **38**, preferably of glass fibers, stiffened by cut out pieces of wire or plastic screen elements **39** and **49** placed respectively above and below the filter pad, and supported by the flange **34**. If desired, the shell could be formed with a perforated lower wall, in which case the lower screen element **49** could be eliminated. The filtering unit was held firmly against the inwardly turned

flange **34** or the perforated lower wall if the latter was used, by a length of stiff wire **46** forming a retainer. One end of the wire was positioned in recess **35**, the first length **47** of the wire extending from the recess toward the center of the filter pad, a second length **48** then being looped at right angles toward the front of the shell, the tip **49** of the loop being located in the depression **36**, and a third length **59** of the wire thereafter being bent in line with the first length of wire and the end of the wire being located in the depression **37**.

At the junction of the first and third lengths of wire with the looped second section, the wire was looped upwardly as shown at **41** and **42**, the loops being bent away from one another. The filter pad assembly was kept firmly pressed against the peripheral bottom flange **34** while the wire retainer was engaged with the recesses in the filter shell walls, but by squeezing loops **31** and **42** together, the ends of the wire could be freed from the recesses **35** and **37** and the retainer then withdrawn, after which the filter assembly could be removed for cleaning. A length of tube **43** was secured to the wall of the strainer and preferably at the jointure between the back and front walls. The upper end **34** projected sufficiently far above the strainer shell to enable the free end of the tube **28** to be pushed onto it. The lower end of the tube **43** was cut away on one side as shown at **45**, and the uncut side was bent forward in order to spread the dirty water delivered by the tube **25** over the top of the filter pad. When the cleaning operation was finished, the tube **26** was merely pulled free from the tube **43**, the filter pad washed and put back.

In using the invention to clean an aquarium of the sizes that were in common use, the bulb **10** was merely held in one hand and intermittently squeezed and relaxed as the suction tube **21** was moved over the bottom. Wherever detritus could be located, the user's other hand being free if necessary could hold the tube **26** out of the way. As the bulb **10** was collapsed, the out-rush of air tightly seated the valve of the housing **12** while the valve of the housing **11** was forced open. When the bulb was allowed to expand, the air entering the bulb through the housing **11** resulted in a closure of the valve and consequently a

partial vacuum was formed within the bulb. This vacuum resulted in water being forced by atmospheric pressure up through the tube 21 and into the bulb. As the bulb was again collapsed, the suction valve was closed and the water held by the bulb was forced into the tube 26.

Thus the intermittent collapsing and expanding from the collapsed condition of the bulb would act to suck water into the bulb and force it into the tube 26 and through the strainer 27 or the strainer unit 23, either of which would retain the detritus held by the water while permitting the cleaned water to flow back into the aquarium. The "suction" developed by the bulb was sufficient to draw the gravel, small-pebbles or like material usually used in aquariums up into the suction tube 21 to thoroughly clean it even as the accumulation of food, etc., was being forced up into the device and through the strainer member used. As larger fragments of gravel and pebbles could pass the filter 23, there was no danger of them jamming the valves 19. If smaller particles of sand and gravel should pass the filter 23, there was little likelihood of these finer particles affecting the valves as they were formed of resilient material and would tend to seat properly even though foreign particles were held by the respective valve seats.

At each operation of collapsing the bulb the gravel or pebbles would tend to fall by gravity back into the aquarium and, as they tumbled down the tube 21 they tended to cleanse themselves of any material clinging thereto. Thus the device of the present invention not only could be used to remove any loose particles of decaying matter fouling the water of the aquarium, but would at the

same time tend to clean the gravel or pebbles lining the bottom of the aquarium. If it was desired to clean the bulb, the strainer 23, the valves or replace the latter, it was only necessary to pull the suction tube 21 out of the valve housing and tube connector 12 and pull the tube 26 off of the valve housing 11 and free the valve housings from the bulb 10, which operation separated all of the component parts for individual attention.

[Figure 182, *Aquarium Drainage Device*, Number 2595965] This was the tube-type undergravel filter was invented by George W. Ludwick of Philadelphia, Pa. in 1952. The vertical tube was normally capped, but at intervals a hose was attached and the water within the tubes was siphoned off. Again, close but no cigar. If Ludwick had incorporated air into the siphon tube, converting it into a vertical air/water return tube, we could credit him as being the first to invent the undergravel filter. Apparently Ludwick was not familiar with the concept of the airlift that had been used in aquariums for many years prior to his invention.

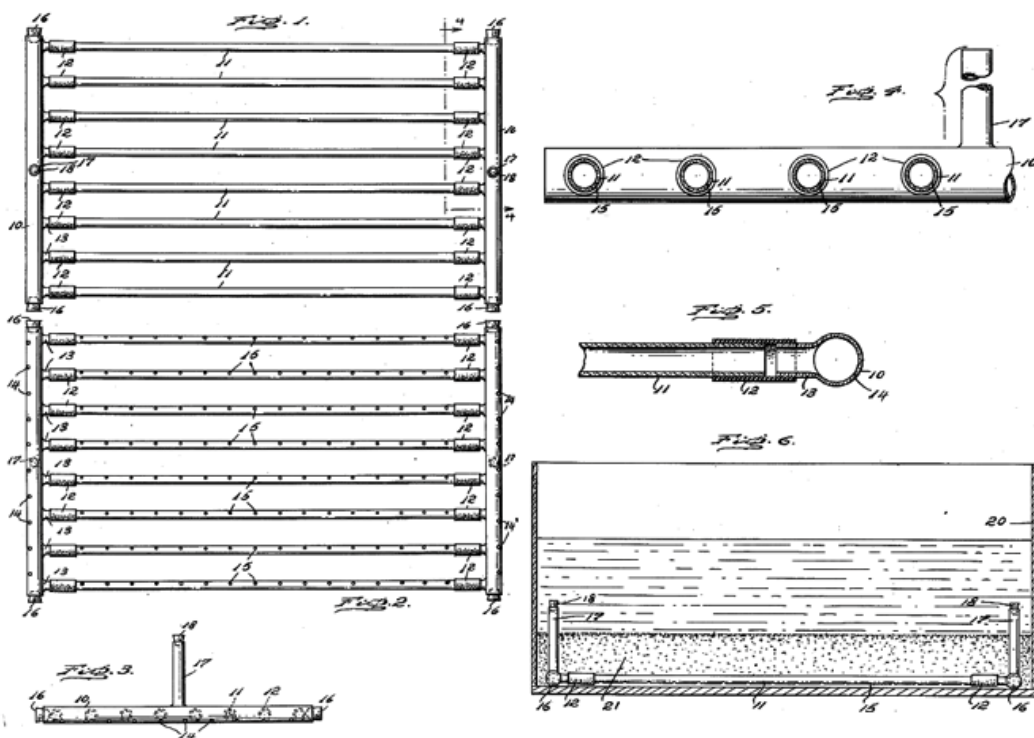

Figure 182: George W. Ludwick's undergravel filter, 1952

In the accompanying drawings, Fig. 1 represents a plan of an apparatus embodying one form of the present invention; Fig. 2 represents a bottom plan; Fig. 3 represents an end elevation; Fig. 4 represents a section on line 4 - 4 of Fig. 2; Fig. 5 represents a sectional detail showing the jointing of the parts and Fig. 6 represents a sectional elevation of an aquarium showing the apparatus of the invention in operative position.

One form of the invention comprised a framework formed by opposite disposed glass tubular headers **10** interconnected by a plurality of laterally spaced glass tubes **11** lying in the same transverse plane and communicating respectively at opposite ends with the respective headers **10**. The tubes **11** were each arranged to be connected at each end to the headers **10** by means of rubber nipples **12**, which fitted respectively over tubular bosses **13** and therefore could be readily removed for cleaning or replaced if broken, but also allowed the framework to be shipped in a knock-down condition. Since the framework in operating position seated upon the bottom of an aquarium and was concealed by a bed of sand, provision was made for the water in the aquarium to enter and fill the headers **10** and tubes **11** by providing a row of inlets **14** in the bottom of each header **10** and a like row of inlets **15** in the bottom of each tube **11**. All of these inlets **14** and **15** were relatively small, for example of the order of one sixty-fourth of an inch, so that particles of sand could be prevented from entering the headers and tubes. The rows of inlets **14** and **15** were offset from the line of contact of the headers and tubes with the bottom of the aquarium to ensure free entrance of the water while filtering out the sand, thus leaving the contaminated water free of sand and ready for syphoning off.

The two headers **19** were open at the ends to receive closures in the form of removable corks **16**, which normally stay in place but could be taken out to permit the insertion of a suitable cleaning brush or the like. Also, the diameter of these headers **10** was preferably larger than the diameter of any tube **11** so that free circulation of the water was ensured. For the purpose of drawing off collected stagnated water from the framework, each header **10** was provided

with an upstanding discharge pipe **17** of a length such that its top open end protruded above the bed of sand at a convenient location for the attachment of a hose for syphoning the stagnant water out of the framework. Normally these open end pipes **17** were closed by corks **18** and were removed only to evacuate the framework, though only one pipe would be used at a time, the second one serving for a reverse evacuation in case that end of the framework became clogged.

In operation, the framework was placed in an aquarium and rested upon the bottom to be covered by a bed of sand **21** having a depth such that the ends of the pipes **17** were readily accessible. After the sand was in place, water **22** was poured in to the required level for fish life. The entering water seeped downward through the sand to enter the inlets **14** and was free of sand and thus filled the headers and tubes. The aquarium was now ready for use and needed no attention until such lapse of time took place as would mean there was a heavy collection of stagnate impregnated water. At that time a cork **18** was removed from its pipe **17**, a hose attached and the liquid contents of the framework syphoned off. The amount withdrawn depended upon the size of the aquarium, but for most aquariums in general home use the syphoning off of one quart sufficed. The evacuation of the framework drew the water **22** downward through the sand **21**, absorbing and carrying off with it collected stagnant residue in the sand and circulating it into the framework. Thus, the sand was maintained clean, free of stagnant material and decomposition gases, making it fertile for plant life while the water was clear and sanitary for the fish. Again after period of time elapsed the syphoning step was repeated and the collected stagnant impregnated water drawn off, and, of course, a like quantity of water was poured into the aquarium as a replacement and the cycle of operations continued.

[**Figure 183, Filter Aerator for Aquaria, Number 2614529**] An early variation on this idea was patented later in 1952 by Thorwald H. Hanson of Rahway, New Jersey and became the inspiration for the funnel type of undergravel filter. In this design, a cylinder (in later designs this was more funnel-shaped), open

at the bottom, was pressed down into the gravel, its upper end connected to an airlift. Like the funnel designs, it did not pull water through all parts of the gravel layer throughout the tank and so was ineffectual.

Fig. 1 is a side elevational view of an aquarium provided with a device made in accordance with **the invention, some parts being broken** away for clearness and showing a goose neck form of head; Fig. 2 is an enlarged fragmentary vertical cross-sectional view of the water pipe and air pipe at the point where the extension connects the two; Fig. 3 is a fragmentary horizontal cross-sectional view taken along line 3 - 3 of Fig. 1, and Fig. 4 is a fragmentary detailed view of a modified form of head.

The aquarium 1 was provided with a bed of fine gravel or very coarse sand 2, which could be of any desired depth but usually from one and one-half to two inches. The aquarium was filled with water to the level 3.

A vertical water-tube 4 of any suitable material, such as glass, metal, plastic or the like was placed in one side of the aquarium. An enlargement or dome 5 was secured at 6 to the lower end 4' of tube 4. This enlargement was of such a diameter that the cross-sectional area thereof was at least three times that of water tube 4. The height of the enlargement was usually around one to one and one-half inches. A lateral projection 5' was provided to act as a stop to gage the level to which the device was inserted into the aquarium gravel 2. A space T was usually left between the open end of enlargement 5 and the bottom of aquarium 1, this space being of the order of one-half inch. The upper end 8 of water tube 4 was straight or was formed into a goose neck with the open end 9 thereof being slightly above water level 3.

An air-tube 10 of lesser diameter than water tube 4 was held in parallel relationship to the water tube by loop 11 or it could be otherwise attached thereto or made integral therewith. The lower end 12 of air tube 10 terminated at the air chamber above the bottom of the aquarium. End 12 fitted into an upward extension 13 which entered section 13' of the water tube. The

diameter of the extension was usually from one-third to one-half the diameter of water tube 4. Plug 15, having a tapered inner face 18, was inserted in the open end of extension 13. The removal of plug 15 provided means for cleaning any accidental accumulation of foreign matter in the extension. End 12 was beveled at an angle to air-tube 10 that it could be fitted as shown in Fig. 2 to permit an air bubble of maximum size, or tube 10 could be twisted to control the size of the effective opening and the size of the bubble. Section 13 was fitted onto water-tube sections 4 and 4' for convenience in the assembly and also to accommodate various lengths of tubes 4 and 4' for various conditions of use.

Goose neck 8 was made detachable in the preferred form and could be replaced by a head of different type as shown in Fig. 4. The upper end 17 of water-tube 4 was beveled at a sharp angle to the horizontal

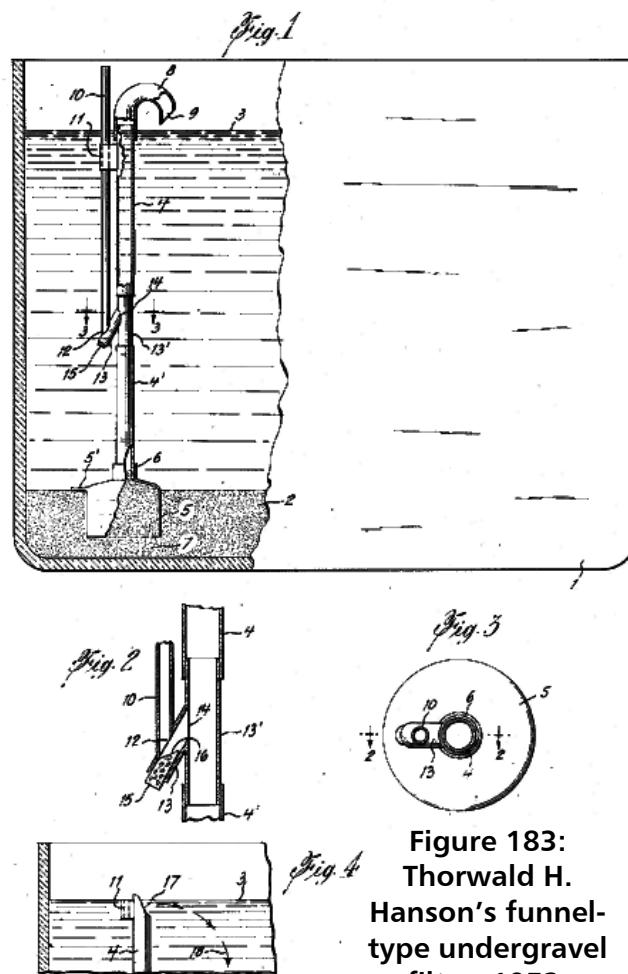

Figure 183:
Thorwald H.
Hanson's funnel-
type undergravel
filter, 1952.

to form a V-shaped notch below the water level. Thereby a circulation of water as shown by arrows **18** throughout the aquarium was obtained. Also the top of tube *4* could terminate below the water level a substantial distance so that noiseless aeration was obtained.

The diving bell shaped base was thin-walled and could be pushed into the gravel and removed without disturbing the aquarium gravel. The term "aquarium gravel" denoted here a fine gravel of about one-eighth inch diameter size. It was slightly coarser than coarse sand. Practically all aquaria had aquarium gravel that provided a footing for the roots of the plants. The upper end of the device could be a short vertical straight tubing of such length and diameter in which the air adjusted in the air chamber would lift the water without back pressure and expel the water and air noiselessly at a predetermined distance below the surface of the aquarium water.

The air tube extended down to the upward extension at the lower end of the water-tube. The upward movement of water set up no back pressure; hence, it was possible to inject air near the bottom of the water tube just above the gravel so that the air stream could be seen at all times. The shape of the air chamber and the shape of the plug and the air tube provided the means of changing the size of the air bubble. The beveled lower end of the air tube provided a means for adjusting the amount of air by the twisting of the air tube so that one could accurately adjust the size of the air bubbles so that they substantially completely filled the water tube. Because of this, the relative sizes of the air and water tubes could be varied to a considerable extent without impairing the functioning of the device. The tapered inner faces of the plug assisted the air in passing from the air tube into the central section of the water tube.

The device could be cleaned in a very simple manner. The user merely twisted the device while lifting it up out of the gravel at the same time; therefore, there was no disturbance of the water in the aquarium, which remained clear. The operation of the device was visible at all times and under all conditions so that necessary adjustments could be readily made.

The device could be shifted to any part of the aquarium and could be put in place by gentle twisting and downward pressure. Because of the construction of the device, a small air pump that was practically noiseless and was of moderate cost could be used. In fact, such a small pump could in some cases serve more than one aquarium. The device being made in sections was readily adaptable to various sizes of aquaria by changing the length of the water tube and air tube. Any kind of head could be placed on the top of the water tube or the head could even be omitted. The several elements could be made of any suitable material but preferably of a transparent plastic so that it was non-breakable.

[**Figure 184, Water Purifying Device for Aquariums, Number 2636473**] The filter devised in 1953 by Albert J. Schwartz and Samuel H. Barbour of Philadelphia consisted of a solid plate with three channels drilled into it, a number of holes being

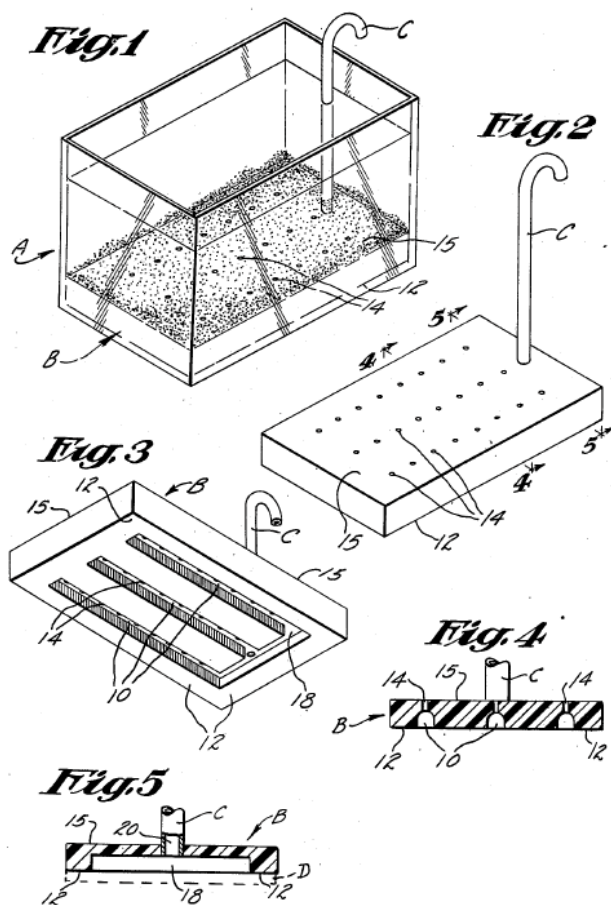

Figure 184: Albert J. Schwartz and Samuel H. Barbour's undergravel filter, 1953.

drilled through each of the tops of the channels, all three emptying into a common channel at one end. The curved siphon tube shown was used to draw the water from the tank into a standard filter (not pictured) and returned to the aquarium. If Schwartz and Barbour had incorporated air into the siphon tube, converting it into a vertical air/water return tube, we could credit them as being the first to invent the flat-bottomed undergravel filter. Again, close but no cigar.

Fig. 1 is a perspective view of an aquarium embodying the plate invention; Fig. 2 is a perspective view of the plate which is an embodiment of the invention; Fig. 3 is a perspective view of the bottom of the plate; Fig. 4 is a sectional view taken along the line 4 - 4 of Fig. 2 and Fig. 5 is a sectional view taken along the line 5 - 5 of Fig. 3.

The invention showed an aquarium or tank, generally designated as **A**, where fish of various types and other aquatic animals could be housed. A plate, generally designated as **B**, covered the entire bottom of an aquarium. The plate **B** had an upper surface **15** and a bottom surface **12**. The bottom surface **12** had a plurality of communicating channels or recesses **10** therein. The bottom surface was in contact **15** with the bottom of the aquarium so that debris or dirt accumulated on the bottom of the aquarium would not clog the communicating channels **10**. The plate **B** was made of plastic material and covered the entire bottom surface of the tank with **20** the sand located above the plate so that the plate was beneath the level of all the contents of the tank.

A plurality of fine holes or openings **14** drilled completely through the channel **10** to the upper surface **15** of the plate permitted water to be drawn through. The fine holes **14** served as a comminuting member to break up particles or granules sucked through. The channels **10** were joined together by a common cross channel. A syphon tube, generally designated as **C**, was mounted at right angles to the plate **B**. The syphon tube **C** had an opening **20** into the common channel **18** and it syphoned water from the bottom of the plate **B** into a standard filter (not shown) where

the water would be cleaned and returned to the tank of water or aquarium.

In other aquariums, the fish droppings and other waste materials such as food normally settled into the sand and decomposed, thereby causing the sand to turn black and foul. With this system the droppings or other waste material were drawn through the fine holes **14** in the plate **B** by the syphon, thereby resulting in a circulatory motion of the entire water within the tank. These particles (droppings or other waste material) were drained from the sand through the syphon tube into a filter (not shown) where the droppings and waste material were removed from the water and the water was returned to the tank as clear water. The plate **B** enabled the water to be drained and the particles broken up so that a minimum of stagnation resulted. The small openings broke the larger pieces of waste material without permitting the sand to be withdrawn from the aquarium. The flooring of an aquarium could be built with the plate **B** either as an integral unit or as a portion firmly fixed to the bottom of the tank. In Fig. 5 is shown in dotted lines a covering **D** that was tightly affixed to the plate **B** whereby flooring for an aquarium was formed.

[**Figure 185, Filter Means for Aquariums, Number 2674574**] Another funnel filter design appeared in 1954, that by Constant Pettas of Montreal, Canada. It was designed to fit in the corner of the tank, although it was also designed as a sediment collector as well. Unlike Hanson's design, the funnel could also be packed with a filter material such as fiberglass. Because they did not pull water throughout all parts of the gravel, these funnel designs were not a success.

Figure 1 is a perspective view of the device in working position in an aquarium; Figure 2 is a sectional elevation of the device; Figure 3 is a cross-section along line 3 - 3 of Figure 2; Figure 4 is a cross-section along line 4 - 4 of Figure 2; and Figure 5 is a fractional longitudinal section showing another way of mounting the device for picking debris from the bottom of the aquarium.

The device comprised a circular fluid inlet chamber or base **1** having side apertures **2** and **6** closed at its lower end by a bottom wall **3** which had a central opening **4** communicating with a central extension **5** of tubular formation coaxial with and extending upwardly from the bottom wall **3**. A second tubular extension **6** of smaller diameter was inserted into and secured to the top end of the lower extension **5** thus forming a shoulder **7**. An upwardly inclined outer flange **8** attached to the bottom edge of the chamber **1** served as an anchor member for firmly securing the device of the invention into the sand bed A of the aquarium B.

A bell shaped filter chamber **9** was attached at its lower larger end to the upper edge of the fluid inlet chamber **1** by having its inwardly curved edge **10** engaging a rim **11** from the upper marginal edge of the chamber **1**. The filter chamber **9** was preferably made of a transparent plastic and was filled with a filtering packing medium **12** such as glass wool. The upper smaller end of the bell shaped filter chamber **9** formed a socket **13** receiving with a snug fit a main tube **14**.

A side air supply tube **16** had an outwardly curved upper end **17** adapted to be connected to a flexible tubing **18** for supplying compressed air, extended alongside a portion of the tube **14** and was curved upwardly at its lower end **19** just before opening into the main tube **14**. A collar **20** secured the air supplying side tube **16** to the main tube **14**.

The device was placed vertically in the aquarium with the fluid inlet chamber **1** embedded into the sand A as shown in Figure 2 and with the upper end **15** of the main tube **14** projecting above the water surface. Compressed air, preferably supplied by a diaphragm air compressor such as commonly used for aquariums, was admitted into the column of water inside the main tube **14** through tubing **18** and the side tube **16**. Air bulbs **21** were formed and rose within the main tube **14**. Thus the air and water mixture within the top part of a main tube **14** had a smaller density than the water in the aquarium whereby an upward water flow was created within the device. Debris loaded water entered the side ap-

ertures **2** and the tubular extensions **5** and **6** of the fluid inlet chamber **1**, passing through the filtering medium **12** in the filter chamber **9**. The filtered water was aerated and discharged at the upper end **15** of the main tube **14**.

The sand bed area lying close to the device of the invention would be cleaned by the water flow entering the side apertures **2** of the fluid inlet chamber **1**, while the sand bed area lying further away from the device would be cleaned by the water flow entering through the bottom aperture **4** of the fluid inlet chamber **1** into the tubular extensions **5** and **6** and directly through the filter packing **12** in the filter chamber **9**.

The device could also be used for removing debris suspended in the water of the aquarium freely resting

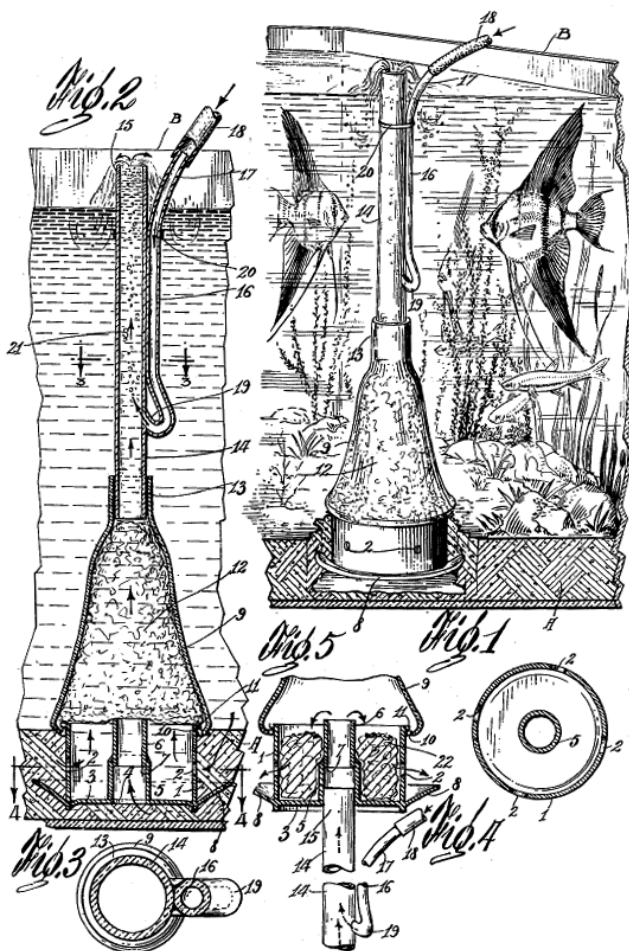

Figure 185:
Constant Pettas' funnel filter design, 1954.

on the sand bed A. For this purpose the arrangement shown in Figure 5 was used. The upper end 15 of the main tube 14 was inserted within the tubular extension 5 of the fluid inlet chamber 1 and the latter was filled with glass wool 22. The device, when so arranged, was held in one hand and the lower end of the main tube 14 was brought close to the debris to be collected. As in the previous case an upward water flow was established within the main tube 14 upon air admission whereby the debris was sucked and discharged onto the glass wool 22 within the fluid inlet chamber 1.

[Figure 186, *Water Filters*, Number 2676921] Mary L. Vansteenkiste, of Montgeron, France, invented these filters in 1954. They were essentially hollow porous cylinders or tubes, embedded with carbon, so when the water passed through the gravel, impurities not removed by the gravel were adsorbed when the water passed through the cylinder. Along with her husband, Vansteenkiste later modified this design and it was advertised and sold in this country during the 1960s and 1970s as the "Invisible French Filter & Aerator." Since it merely involved inserting a cylinder or tube, it could be installed and uninstalled without taking down the tank.

Fig. 1 is a fragmentary sectional view of an aquarium and of one form of water filter embodying the features of the invention; Fig. 2 is a fragmentary sectional view of an aquarium and of a filter of a different type embodying the features of the invention and Fig. 3 is a graph plotting liquid volume against air supplied and showing curves indicating the filter and for prior conventional filters.

The numeral 10 represented an aquarium wall that was open at the top and to the lower end of which there was connected a bottom 11. Between the bottom and the lower end of the wall 10 was an internal sealing member 12 and an external sealing member 13. The external sealing member 13 was held in place by a bent molding strip 14 that surrounded the entire bottom of the aquarium. On the bottom of the aquarium was a layer of sand, as indicated at 15, and into this sand there was embedded a hollow porous cylinder 16 into which water from the aquarium

could pass. This water would be filtered through the sand and through the porous wall of the cylinder 16. Within this cylinder there were preferably provided particles of carbon to absorb certain of the impurities of the water passing through the filter and not removed by the sand or the wall of the cylinder.

Extending vertically from one end of the porous cylinder was an outlet tube 17 through which the water was drawn, the ends of the cylinder being closed as indicated at 13 and 19. Surrounding this tube 17 and resting upon the porous cylinder 16 was a cup-shaped supporting, plate or member 18' for receiving and supporting a large vertically extending cylinder 19'. The water would flow into this cylinder 19', fill it and pass outwardly through a nozzle cap 20. The water flow was caused by the presence of air being supplied to the large tube 19'. This air was supplied by a motor pump device 21 having a pump 22 and an electric motor 23. The electric motor was connected by an electric cord 24 and a plug 25 to a wall receptacle. The device 21 was supported on the edge of of

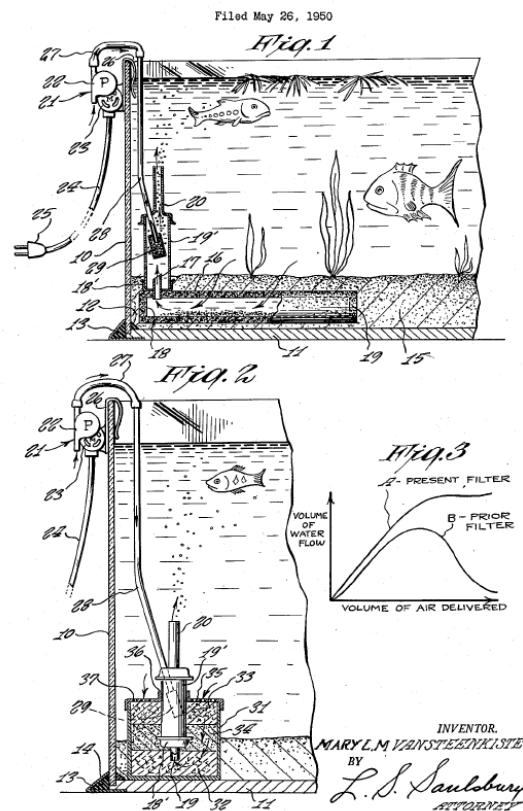

Figure 186: Mary L. Vansteenkiste's porous filter designs, 1954.

the aquarium wall **10** by a clip bracket **28**. To the pump **21** there was connected a rubber hose **27** that extended over the upper edge of the aquarium wall **10**.

A glass or plastic tube **23** extended from the rubber hose **27** and this tube had a cylindrical shaped porous block **29** connected to its lower end. This porous block or head **29** would give off a great volume of small bubbles of air so that a constant chain of them would pass upwardly through the nozzle cap **20**. This air, as it left the nozzle cap, left space for water to enter the cylinder **19'** whereby the water flow through the filter was maintained. This air not only maintained the flow of water in the filter, but also aerated the water. The provision of the small air bubble flow and the large cylinder tube **19'** made possible a filter construction that would not become clogged. In the opposite case of a small cylinder tube and large bubbles passing upwardly through the tube, calcium compounds deposit heavily upon the inner wall of the tube. The tube **28** extended through an opening in the nozzle cap **20**. The porous block **29** could remain as a separate unit and could be fitted to the end of the glass or plastic tube **28**. The block **29** could be made from a mass of small granules fused or pressed together to comprise a self-contained solid block having a great number of small pores through which air was projected in such a manner as to give off very small bubbles.

Referring to Fig. 2, there was shown a slightly different type of a filtering arrangement. A cup-shaped container **31** was provided with bottom and top layers of glass wool, as indicated at **32** and **33**, and with an intermediate layer of carbon particles, as indicated at **34**. Over the top of the cup-shaped member **31** there was fixed a cap **35** having a flanged central opening **38** and perforations **37**. Water, as indicated by the arrows, passed downwardly through the perforations **37** and through the layers of material lying within the cup-shaped member or receptacle **31**. This member was supported upon the bottom of the aquarium tank.

The tube **19'** extended through the flanged opening **36** of the cap, filled it and was embedded in the lay-

ers of material lying within the receptacle. The lower end of the tube **19'** had the bottom cap **18'** thereon with the small tube **19** placed therefrom. The water, after having passed through the layers of the material within the cup-shaped member **31**, passed upwardly into the tube **19** where it was mixed with the air delivered through the block **29** for its outward flow through the nozzle **20**. The principle of operation of this filter was the same as that above discussed and the only difference was in the arrangement of the filtering material about the vertically extending cylinder arrangement **19**.

In Fig. 3, there were plotted curves of volume of air delivered against the volume of the water flow. Curve **A** was for the present filter while curve **B** represents the curve for prior s using a small cylinder and large bubbles. The volume flow of water through the filter had been increased by the use of small air bubbles and by the use of a large diameter cylinder **19'**. With the large bubbles, as would be indicated by the outer end of the curve **B**, the volume flow of water could be cut off while with the present filter this volume flow reached its maximum and remained at this capacity. The present filter thus out-performed the prior s as exemplified by these curves.

[Figure 187, Aquarium Filter, Number 2730496]

A design that was patented by Joseph L. Zavod in 1956 utilized a perforated tube below the gravel. It had a vertical air/water return tube that could be elongated or shortened via a sleeve that surrounded one portion of it. It had cleanout plugs at various strategic places, although these could be used only when the filter was taken out of the aquarium. The lower part of the diagram shows the specially designed air chamber that allowed a greater volume of air to be introduced, thus increasing the air/water flow through the outlet tube. The return spout could be rotated so that the water drawn from the gravel could be removed from the tank.

Figure 1 is a side elevational view of the present filter as assembled in an aquarium, parts being broken away to show details of construction; Figure 2 is an enlarged sectional view taken on the line 2 - 2 of Figure 1 with additional parts being broken away to

show details of construction; Figure 3 is a side elevational view of a modified form of the filter shown assembled in a tank and

Figure 4 is an enlarged elevational view of the bubble chamber of the device shown in Figure 3, parts being broken away and shown in section to illustrate details of construction.

The invention comprised a perforated chamber adapted to be positioned in an aquarium beneath the gravel bed, a vertically adjustable return tube removably connected to the perforated chamber and an air inlet tube connected to a further chamber embracing a portion of the return tube to develop suction whereby water in the aquarium would be pulled through the gravel bed into the perforated chamber and into the return tube. While the filter could be constructed of any suitable material, it was preferred that it be constituted of colorless, transparent, non-toxic plastics, such as the vinyl plastics. Referring to Figures 1 and 2, the filter comprised an elongated, preferably cylindrical, chamber or tube 10 which was positioned within or beneath the gravel bed 12 of a conventional aquarium tank 14. The chamber 10 included a plurality of perforations 16 and a curved end 18 adjacent one side 20 of the tank. The opposite side of the chamber was fitted with a removable clean-out plug 22.

Removably received in the curved end 18 of the chamber 10 was a vertically extending tube 24. Telescoped with the tube 24 was a further tube 26 having a curved spout 28 at its upper end. The tube 26 was slidable on the tube 24 and, because of the closeness of fit between the tubes, the tube 26 could be moved and retained in any desired adjusted vertical position to accommodate tanks of varying capacity. The tubes 24 and 26 constituted the return tube portion of the filter. The spout 28 could be positioned to return

water to the tank in normal use as shown in the solid lines in Figure 1 or could be turned away from the tank to remove the water from the tank as shown in dotted lines in Figure 1. Any suitable clip 30 could be used to removably suspend the return tubes and associated filter chamber 10 on the side 20 of the tank as shown in Figure 1.

Intermediate the ends of the inner tube 24 of the return tube, a plurality of circumferentially spaced apertures 32 were provided. Secured to tube 24 and embracing that portion of the tube which included the apertures 32 was a further chamber 36 which preferably extended perpendicular to the axis of the tube 24. The chamber 36 was preferably cylindrical and was provided with removable clean out plugs 38 at its opposite ends. Secured to and extending into the chamber 36 was an air inlet tube 40. This air inlet tube was secured in the chamber 36 in a position perpendicular to its axis and adjacent the tube 24 as shown in Figure 2. The portion of the tube 40 which was confined within the chamber 36 was provided with diametrically opposed apertures 42. A hose 44 was adapted to be attached to the air inlet tube 40 and to any suitable aerator pump.

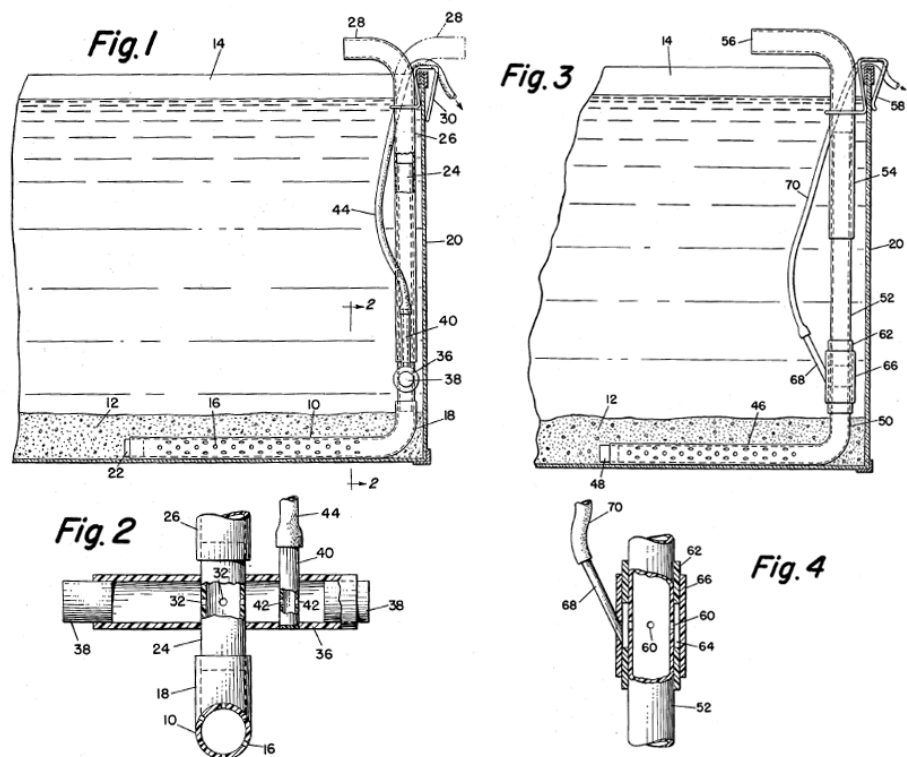

Figure 187: Joseph L. Zavod's undergravel filter, 1956.

In use, air from the aerator was delivered to the bubble chamber **36**, the air emitting from the apertures **42** of the air inlet tube **40**. The flow of air from the apertures **42** through the apertures **32** and up the return tube **24, 28** created a substantial vacuum which drew water from the tank through the gravel bed **12** into the chamber **10** through its perforations **16**, the filtered water being returned to the tank via the return tube **24, 28**. Because of the construction of the chamber **36**, the location of the circumferentially spaced apertures **32** in the return tube **24** and the diametrically opposed apertures **42** in the air inlet tube **40**, a bubble of air approximating the size of the chamber **36** was produced before it entered the apertures **32** and the return tube **24**. This created such an increased suction that the present filter attained a capacity of 15 to 17.5 gallons per hour when the filter was used with a small 2-watt vibrator pump as opposed to the capacity of 1 to 3 gallons per hour using the present conventional filters with the same pump.

The modified form of the filter shown in Figures 3 and 4 operated on the same principle as the filter above described except that the horizontal bubble chamber **36** was placed coaxially with the return tube. The modified form of the filter comprised a perforated, preferably cylindrical chamber or tube **46** which was positioned in or beneath the gravel bed **12** of a conventional aquarium tank **14**. One end of the perforated chamber was provided with a removable clean-out plug **48** and the other or curved end **50** was removably secured to or integral with a vertically extending tube **52**. The tube **52** was slidably and adjustably received within a further telescoping tube **54** having a curved spout **56** at its upper end. The telescoped tubes **52** and **54** constituted the return tube portion of the present filter and, like the previously described filter, were vertically adjustable to accommodate tanks of varying capacity. The return tube and associated perforated filtering chamber **46** could be removably retained in the aquarium tank by any suitable clip **58**.

A plurality of circumferentially spaced apertures **60** were provided in the tube **52** intermediate its ends and an inner sleeve **62** was secured coaxially with

the tube **52**. The sleeve **62** included a cut-out portion **64** constituting a bubble chamber embracing the portion of the tube **52** which included the apertures **60**, as shown in Figure 4. Secured to the inner sleeve **62** coaxially was an outer sleeve **66**. Secured at an angle to the outer sleeve **66** and communicative with the bubble chamber **64** was an air inlet tube **68** adapted to removably receive a hose **70** operatively connected to any suitable aerator pump.

In use, the modified filter operated substantially in the same way as the one shown in Figures 1 and 2. Air was delivered from the aerator to the chamber **64** and before it entered the circumferentially spaced apertures **60** in the return tube **52** it took the form of a bubble approximating the size or capacity of the chamber **64**. In so doing and in passing through the apertures **60** and up the return tube, a substantial suction was created pulling water from the tank through the gravel bed into the perforated filtering chamber **46** and into the return tube. The filtered water was returned to the tank through the spout **56**. If desired, the spout could be turned away from the tank, in which case the water would be evacuated from the tank. As in the case of the filter described in connection with Figures 1 and 2 the modified filter of Figures 3 and 4 had a capacity far in excess of the present conventional filters.

[**Figure 188, Home Aquarium Circulator and Aerator, Number 2744065**] A design patented in 1956 by Joseph S. Lacey of Upper Darby, Pennsylvania consisted of a funnel set into the gravel with a vertical air/water return tube attached to the narrow end, along with an ordinary air stone in the main part of the funnel. The problem with all of these funnel designs, of course, is that the water was pulled only through the gravel near the funnel.

The numeral **10** represented a conventional tank or aquarium and was provided with a bed of sand **12** on its bottom **14**. The sand could be of any desired depth but usually was only of a few inches in depth. The aquarium was filled with water to the level **16**.

A vertical tube **18**, which was preferably formed of plastic, was placed within the tank preferably adja-

cent one of the side walls. The tube **18** had its upper end **20** projecting above the water level **16** and its lower end **22** was slightly flared outwardly to receive a tapered neck **24**. The neck was integral with a conical member **26**. The member **26** had an open base end **28** which was embedded in the sand and was spaced vertically from the bottom **14** of the aquarium. The conical member **26** could be easily embedded in the sand **12** and could be removed without unduly disturbing the sand. The neck **24** extended axially from the open minor end or apex **30** of the member **26** and was frictionally inserted in the end **22** of the tube **18**. A small plastic air tube **32** was attached at its enlarged lower end to a tube **34** which projected through an opening **36** in the side wall of the member **26**. The opening **36** was formed by a resilient gasket **38**, which prevented the air from escaping through the side wall of the member **26**.

The tube **34** extended diagonally through the side wall and was slidably disposed through the gasket **38**, as shown in the drawing, and had its inner end **40** placed substantially at the center line of the member **26**. A porous air stone **42** was fixedly placed around at one end of the tube and diagonally disposed in the center of the member **26**. Air under low pressure was introduced into the aquarium through the small plastic air tube **32** and passed through the tube **34** to be released through the porous stone **42** where the air was broken up into many small bubbles which traveled up through the neck **24** and the tube **18** to the top of the tube where they were released onto the water surface **16**. These bubbles forced water out of the tube **18** as they traveled upwardly to bubble over at the top of the tube. The mixture of air and water in the member **26** had a lower specific gravity than that of water alone and the rising air bubbles exerted a lifting force on the water.

The release of the bubbles in a concentrated manner in the member **26** produced a venturi action, which sucked in the putrid or stagnant water in the sand **12** under the base of the member **26**. The putrid or stagnant water was thus pulled in or sucked into the member **26**, as indicated by the arrows in the drawing. The water drawn into the member **26** was replaced by the water above the sand and the water

was constantly drawn down, the water level being replaced by the water bubbling over at the top of the tube **18**. It was to be particularly noted that the stagnant water was concentrated in an area within the member **26** due to the shape of the member **26** and the water came in immediate contact with the many air bubbles released by the stone **42**. Due to the conical shape of the member **26** at its upper end, the air bubbles were retained in longer contact with the stagnant or putrid water as it was forced up the tube **18**. Any suspended or foreign material in the water would be pulled down into the sand and filtered by the sand from the water.

Because of the simplicity of the device and its few parts, it could be easily removed from the aquarium for cleaning without disturbing the whole tank. Because of the air lift action an efficient and constant circulation was provided, distinguishing itself from the slow and sluggish action of conventional gravity siphon devices of the time.

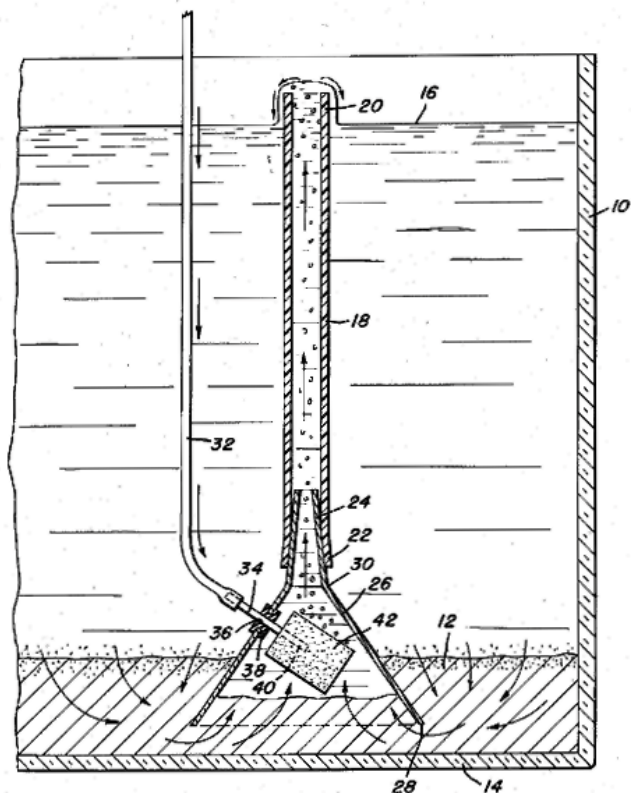

Figure 188:
Joseph S. Lacey's funnel filter design, 1956.

[Figure 189, *Aquarium Device, Number 2748075*] The earliest design for a slotted-box undergravel filter - this one did use an airlift - was invented in 1956 by Norman G. Hovlid of Long Beach, California and was subsequently manufactured by the Miracle Filter Company in that city. It was a commercial success and Hovlid can be considered as the first to invent a true undergravel filter, although other types of undergravel filter designs would follow in subsequent decades.

Figure 1 is a fragmentary side elevation, partly in section of an aquarium embodying the present invention; Figure 2 is a horizontal sectional view taken on line 2 - 2 of Figure 1 showing the construction of the apparatus; Figure 3 is a side elevation of a detail of the apparatus; Figure 4 is an enlarged detail sectional view of the lower end detail shown in Figure 3 and Figure 5 is a longitudinal vertical sectional view of a large aquarium showing multiple installations of the apparatus of the invention.

Referring to the drawings, the preferred form of apparatus embodying the present invention was adapted for use with a conventional domestic aquarium 13 and broadly included a support 10 upon which was disposed glass wool and/or gravel 14 and 15, respectively. The support 10 was spaced above the bottom of the aquarium 13 so as to define a clean-water collection chamber 9 between the underside of the support and the bottom of the aquarium. The support 10 was formed over substantially its entire area with a plurality of openings 11 which permitted the free downward movement

of water through the glass wool and/or gravel 14 and 15 into the clean-water collection chamber 9. Preferably the openings 11 would be small enough in area to substantially restrain all of the particles of gravel 15 from falling into the clean-water collection chamber 9. The glass wool 14 would then not be required.

These openings 11, however, should be adequate in number and large enough in area to permit "flotation" of substantially all of the gravel particles 15. The term "flotation" used here relates to the surrounding of each gravel particle 15 with free flowing

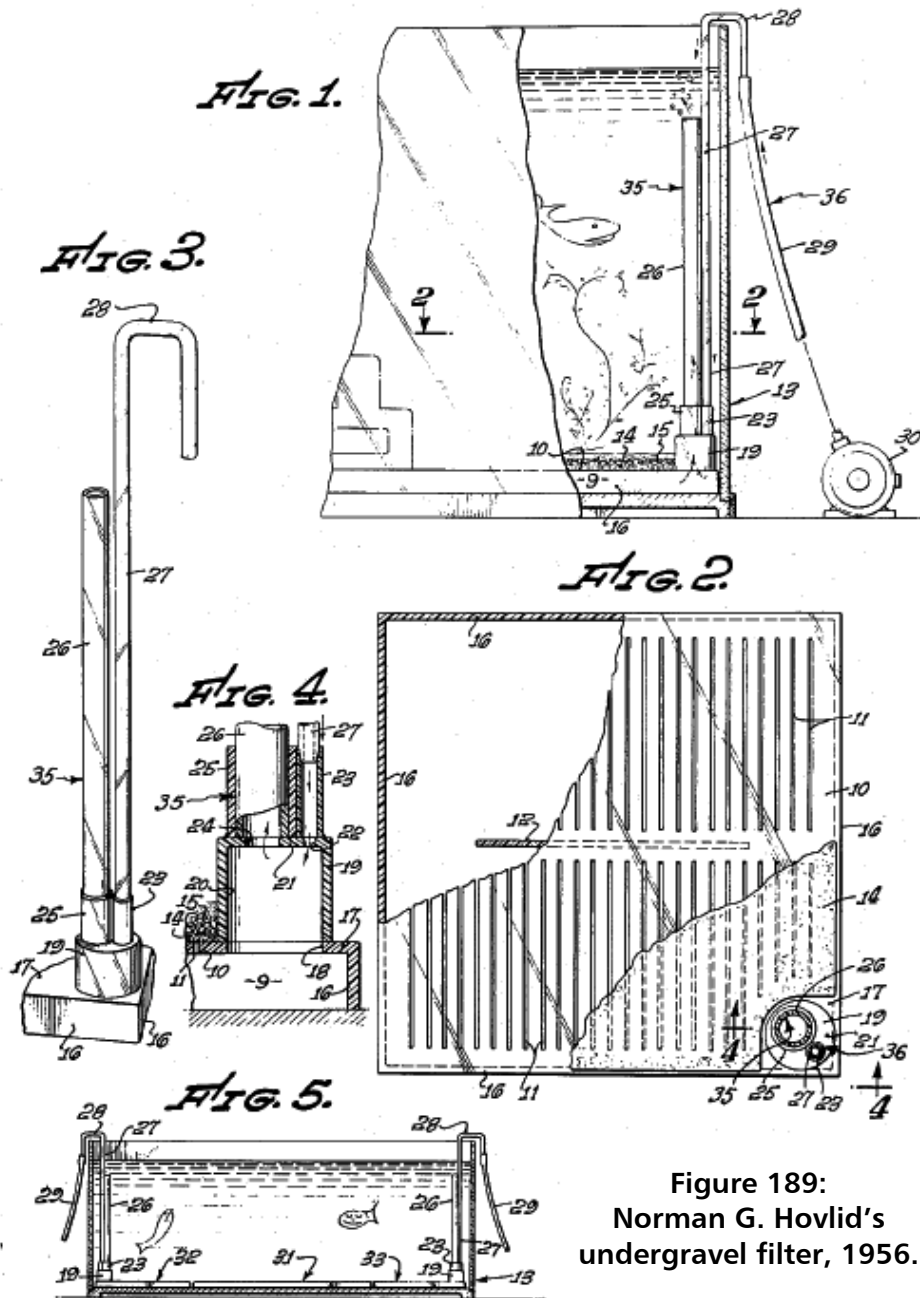

Figure 189:
Norman G. Hovlid's
undergravel filter, 1956.

water whereby the maximum volume and hence weight of each particle would be displaced by such water. In this manner, the gravel particles **15** would remain comparatively loose and hence would not tend to become packed. The apparatus also included passage means, generally designated **35** (to be described fully later), for conducting water upwardly from the clean-water collection chamber to the upper portion of the aquarium **13**, as well as means, generally designated **36** (also to be described fully later), for effecting the downward circulation of water into the clean-water collection chamber **9** and upwardly through the aforementioned passage means **35** into the upper portion of the aquarium **11**.

With this arrangement, the aquarium sewage would be urged downwardly into the spaces between the gravel particles **15**. Here the aerobic bacteria existing within these spaces converted such trapped sewage into non-toxic chemical compounds. These aerobic bacteria have been found to flourish in the spaces between the gravel particles inasmuch as the conditions therein were ideal for their rapid reproduction. The downwardly moving water carried all of the oxygen required for the propagation of the aerobic bacteria. The "flotation" of the gravel particles **15** prevented the sewage from causing the gravel to become tightly packed, and hence the free downward circulation of water would not be interrupted. The gravel **15** could be properly termed a "conversion bed" inasmuch as the water-borne sewage was converted into non-toxic chemical compounds within its confines. The sewage-free water then descended into the clean-water collection chamber **9** from which it was returned through passage means **35** to the upper portion of the aquarium **13**.

With regard to a more particular description of the preferred form of apparatus, the support **10** comprised a thin flat planular plate **10**, preferably of plastic or like non-corrosive material. The entire apparatus was preferably of plastic, was economical, easily fabricated, durable and non-corrosive. The device could be transparent or colored, depending upon the particular motif of the aquarium itself. The invention was, of course, in no way limited to any such selection of materials. The plate **10** was perforated by parallel transverse slots **11** extending from a point adjacently one edge to a point adjacent to a center line normal thereto. Thus, two series of slots **11** were present, their adjacent ends being spaced to accommodate a central vertical supporting bar **12**. The total

area of the plate **10** when disposed horizontally within the aquarium, generally indicated by the numeral **13**, was preferably that of the bottom of the aquarium to provide an entire removable or false perforated bottom.

As indicated in Figure 5, larger aquariums could utilize multiples of the platforms with or without the associated circulating and aerating means. The area of the openings **70** of the plate **10** was preferably between **10** to **60** per cent of the total area, thus to insure both adequate water passage and ample supporting surface for glass wool and/or gravel filtering medium, indicated at **14** and **15** respectively (Figures 2 and 4).

For supporting the plate **10** in an upwardly spaced relation to the bottom of the aquarium, side edge pieces **16** were attached or formed integrally with the plate. Where but a single unit was to cover the entire aquarium floor, the side pieces **16** could be uninterrupted and joined at the corners of the plate. If, however, multiple units as indicated in Figure 5, were to be employed, at least some of the side pieces were intercepted or perforated to permit free flow of water from one to another. The height of the side pieces was not critical, but was such to insure free water flow under the plate **10** without appreciably diminishing the useful internal height of the aquarium. The height of the side pieces was uniform and was equal in height to that of the central supporting bar **12** so that the plate was supported substantially parallel to the bottom of the aquarium and constituted a perforated false bottom uniformly spaced therefrom.

At one corner of the platform **10** the slots **11** terminated short of the edge to provide a free space **17** through which an aperture **18** of substantial size was formed. The edges of the aperture **18** conform with and sealingly engaged the lower edges of a cylindrical member **19** forming an air and water or bubble-forming chamber **20**. The upper end of the chamber **20** was closed by a cover **21** having at one side an air inlet aperture **22** communicating with an air inlet nipple **23** of larger internal diameter than the air inlet aperture **22**. Adjacent the air inlet aperture **22** was a water and bubble aperture **24** communicating with a circulating tube nipple **25**. Within the nipple **24** was seated the lower end of the circulating tube **26**, the internal diameter of which was greater than the diameter of the water and bubble aperture **24**. Air at a pressure only slightly exceeding the water pressure in the chamber **20** induced by the hydrostatic head there above, was

supplied to the aperture **22** through nipple **23** from an air supply tube **27**, the lower end of which was seated in the nipple. The upper end of the air supply tube **27** was formed with a goose neck **25** to press over the edge of the side of the aquarium and its end attached by a flexible tube **29** to an air supply pump **30** of conventional design.

For packaging, the circulating tube **26** and air supply tube **27** could be laid against the bottom of the plate **10** within the confines of the edge pieces **16**. If desired, the cylindrical chamber forming member **19** could also be detachable and the height of the edge pieces **16** could be such as to secure such member thereto to provide a flat package. For use, the tube **26** was inserted in the nipple **25** and the tube **27** was inserted in the nipple **23**. With the aquarium empty, the plate was then lowered to the bottom. The edge pieces **16** and supporting bar **12** located the plate horizontally in uniform spaced relation above the bottom of the aquarium. With the plate so positioned, filtering material such as the glass wool **14** and/or sand or gravel **15** could be laid over the upper surface as illustrated. The aquarium was then filled with fresh water, the fish were placed therein and plants, food or decorative pieces were inserted.

In the operation of the device, either continuously or intermittently, air was supplied from the pump **30** through tubes **29** and **30** to the chamber **20** at a pressure only slightly exceeding the water pressure at the bottom of the aquarium. Thus the accumulation of air in the chamber was gradual, its flow also being limited by the restricted orifice **22** through which the nipple **23** connected with the chamber **20**. Water from below the plate **10** would enter the chamber **20** and lower end of tube **26**. As the air accumulated in chamber **20**, it formed a bubble, which by virtue of the diameter of the chamber was of greater dimension than the aperture **24** or the internal diameter of the tube **26**. When the surface tension of the water was overcome by the pressure of the air bubble, the buoyancy of the bubble overcame the weight of water there above in the tube **26**, and the bubble squeezed through aperture **24** and expanded in tube **26** moving upwardly to carry before it the water there above, thus acting to pump water upwardly through the tube. In operation such bubbles successively passed into the tube between entrances of limited increments of water so that the individual bubbles did not lift a whole column of water in the tube, except perhaps, when operation was first initiated.

As the water was then pumped up through the tube **26**, replacement water entered the chamber **20** from beneath the plate **10**. Thus, a continuous circulation was achieved, and since the plate was uniformly perforated by slots **11**, a uniform downward flow of water through the entire filter area was insured. Since the air and water were in contact in the chamber **20** and throughout their travel up the tube **26**, toxic gases generated by the anaerobic bacteria entered the bubble to be carried to the water surface, while oxygen from the bubble re-oxygenated the water that had been purified by passage through the filter. The top of the circulating tube **26** was maintained below the surface of the water, and thus as the bubbles emerged they expanded and broke while completing their travel to the surface, whereby filtering and oxygenating the water while liberating the noxious gases to the atmosphere.

The precise structure of the plate **10** was dependent upon several conflicting forces. Although it was desirable that the percentage area of the slots **11** be as high as possible relative to the total area of the plate, there was a certain maximum percentage for each thickness of plate **10** that could be selected. When this maximum was exceeded, there was simply not enough plate material left to lend sufficient physical rigidity thereto to maintain a predetermined shape, as well as support a layer of sand or gravel or a combination thereof on the upper surface of the plate. In the event a relatively heavy layer of sand and gravel was to be placed on the plate **10**, the thickness of the plate had either be increased or the ratio of the area of the slots to the total plate area had to be cut down to give the plate the necessary physical rigidity to support such a relatively heavy load.

A large percentage of slot or opening area relative to total plate area was desirable as it permitted circulation of water through the sand bed in sufficient quantity that the growth of aerobic bacteria was stimulated. Likewise, a relatively thick layer of sand was desirable in that it provided an environment in which the aerobic bacteria developed and one that took waste material a sufficient length of time to pass through for it to be fully converted by the bacteria during this passage. However, if the thickness of the sand bed was excessive, the circulation of the oxygen-bearing water there was so slight that the aerobic bacteria did not develop in sufficient quantities to convert waste material falling to the bottom of the aquarium. Failure of waste material to be so convert-

ed ultimately fouled the water in the aquarium to the extent that it was impossible for fish to live.

Therefore, the thickness of the sand bed had to be sufficient to provide a healthy environment in which aerobic bacterial could develop, and that the thickness of the bed and the percentage area of the plate that was in the form of openings or slots had to be so adjusted to that thickness to permit circulation of water through the bed in sufficient quantity to furnish adequate oxygen to the bacteria, but with the rate of the circulation being sufficiently slow that solid organic waste would be converted to materials harmless to fish prior to passing through the bed.

[Figure 190, Filter for Tanks, Number 2786026]

The last of the undergravel filter designs of this decade was a variation of the funnel type, patented in 1957 by Ludwig Stark of Springfield, New Jersey. Stark's filter consisted of a hollow casing shaped like a bell, the bottom of which was embedded in the gravel. It was weighted so it would not rise to the surface. There were slots in the embedded part that allowed water to flow into the bell through the surrounding gravel. Air was pumped into the bell, bringing the water up through the gravel and to the top of the bell and ultimately out into a filter box hung at one corner of the tank.

Fig. 1 is a fragmentary vertical sectional view of a device embodying the invention shown positioned in a tank; Fig. 2 is a bottom plan, partly fragmentary view thereof, taken on line 2 - 2 of Fig. 1; Fig. 3 is a vertical, sectional and partly perspective view of the device of the invention shown positioned in a tank and Fig. 4 is a schematic vertical sectional view to illustrate the "sweeping" action attained in the use of the invention.

This invention comprised a filter 10 for use in a tank 11 containing a volume of liquid

12 having a level 13 and a bed of comminuted particles 14 such as sand, and a source of gas under pressure, schematically illustrated in the drawings as the air pressure hose 15 that was connected beyond the broken end 16 shown in Fig. 3 to a pump (not shown) or other source of gas under pressure.

The filter 10 of this invention comprised a casing 20 (Fig. 1) adapted to be positioned in the tank at the bottom thereof and having a hollow interior terminating in the large opening 20 (Fig. 3) at the bottom thereof and in a much smaller opening 19 (Fig. 1) at the top of the casing. A pipe 22 was secured to the casing as at 23 (Fig. 1) and opened at one end 24 thereof interiorly of the casing below the small opening 19 at the top of the casing so that as gas under pressure was pumped through the pipe 22, the gas (as, for example, air bubbles) would flow upwardly in the casing and through the small opening 19 at the top of the casing, stimulating a flow of water from the bottom of the tank, through the casing end out of the small opening at the top as indicated by the arrows in Fig. 4.

To enhance this sweeping action, the lower end of the casing could be provided with a plurality of slots or apertures 25. The slots or apertures 25 of the lower end of the casing were preferably proportioned to

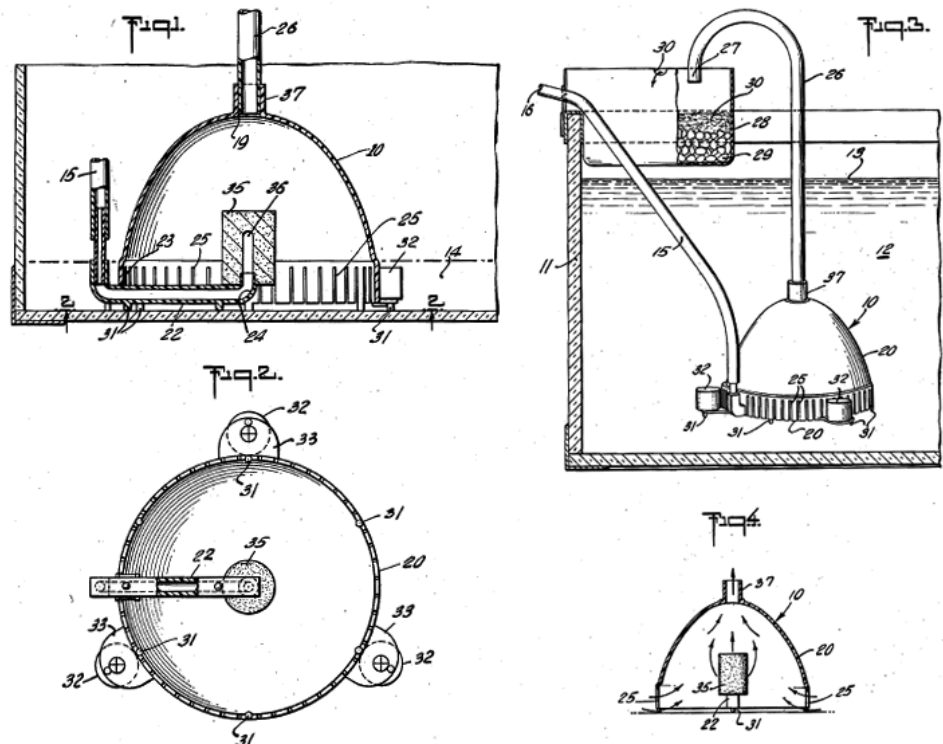

Figure 190: Ludwig Stark's funnel-type undergravel filter, 1957.

extend for a substantial portion of the height of the bed 14. A tube 26 could be secured to the casing in line with the small opening 19 at the top of the casing to direct the flow of air and liquid upwardly from the opening 19 through the tube 26 and out of the downwardly bent end portion 27 of the tube. Liquid discharged from the downwardly bent portion 27 could be passed through a device 28 that could be interposed between the downwardly bent portion 27 and the water level 13 and which could contain filtering or additive media 29 and 30. The purifying device 28 shown in Fig. 3 of the drawings was one of an infinite variety of such devices with which the invention could be successfully used.

A plurality of spacer legs 31 could be provided extending from the lower edge of the casing, to space the same from the floor of the tank, as shown in Fig. 1 and also to enhance the sweeping action above mentioned so that not only would the tank liquid be swept through the bed 14 of comminuted particles but also the bed and floor of the tank would be swept in operation of the device. The casing 10 could be weighted by suitable means, such as by making the casing of inherently heavy material or, as shown in Figs. 2 and 3, by securing a plurality of weight members 32 to the casing, or to extensions 33 thereof. A filtering stone 35 could be secured to the free end of the pipe 22 and provided with a recess 36 therein with which the free end 24 of the pipe 22 communicated as shown in Fig. 1. The casing 10 was preferably semispherical in cross section, as shown in Fig. 1, and could be provided at the top thereof with a fitting 37 aligned with the small opening 19 for connection of one end of tube 26 therewith in registry with the opening 19.

[Figure 191, *Heated Aquarium*, Number 2566990] Two inventions that concerned heating appeared during this decade. The first was awarded to Andrew Mahle of Oakland, California in 1951. This apparatus was designed to be an integral part of the aquarium but the inventor provided no details of the materials used or the methods for sealing the unit. Presumably everything except the glass panels for the aquarium was made of metal and I can only further presume that the material used was resistant to water, such as stainless steel. It should be noted that, for safety's sake, it is much better to have any submersible heater/thermostat combination as a separate,

stand-alone device, since then and only then can it be made in such a manner as to tolerate prolonged immersion in the water. Figure 1 is a perspective view of an aquarium structure embodying the features of the invention; Figure 2 is an enlarged fragmentary plan section taken at one corner of the aquarium and at the level of an electric heating coil of the assembly; Figure 3 is an inside perspective view of a removable member of the aquarium structure which mounts the heating coil and the temperature control for the aquarium in unitary association; Figure 4 is an outside perspective view of the member of Figure 3 and the elements which it mounts and Figure 5 is a fragmentary transverse section of the upper portion of the aquarium taken at an upright plane through the line 5-5 of Figure 1.

The description was written in a heavy-handed patent jargon, and since it dealt mainly with descrip-

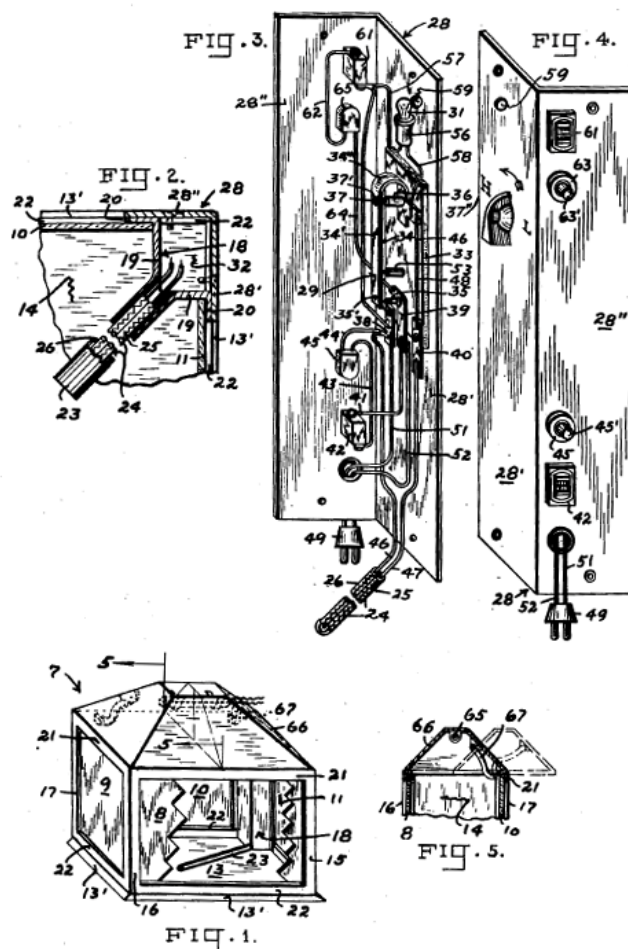

Figure 191: Andrew Mahle's integral heating design, 1951.

tions of electrical connections among wires, I think the figures and the figure description are sufficient here for most aquarists.

[Figure 192, *Aquarium Heating*, Number 2805313] The invention of Charles J. Lumb, Jr. of Milford, New Jersey in 1957 did separate the heating elements from the tank via a coil size of the entire bottom of the tank located underneath the aquarium. These designs were expensive and clumsy, however, compared to the cheap test tube types that had been available for many years prior to this.

Figure 1 is a perspective view of the aquarium of the invention; Figure 2 is a view in section taken substantially along line 2 - 2 of Figure 1; Figure 3 is an enlarged view of the bottom wall of the aquarium of Figure 1 embodying the novel heating means; Figure 4 is an enlarged fragmentary section of the structure of Figure 3 and Figure 5 is a graph of water and ambient temperature curves illustrating the operational characteristics of the invention.

The novel aquarium of the invention was shown in Figure 1 of the drawing for illustrative purposes only, as comprising a generally rectangular tank having side walls or panels 10 and 11, end walls or panels 12 and 13, and a bottom wall or panel 14. The various walls or panels were properly joined at their adjacent surfaces to form a sealed container and could be formed of suitable transparent material such as glass, plastic, etc., to thereby form an enclosure whose contents could be readily viewed from the outside by an observer.

The tank or container was provided with top and bottom reinforcing or ornamental strips 15 and 16 as well as end strips 17, with strip 16 extending below the bottom wall or panel 14 so as to define not only a rigid support for

the container but, with the bottom wall or panel 14, a central chamber 18 (better shown in Figure 2 for a purpose to be described) appear.

To heat the contents of the tank or container in accordance with the invention, the bottom wall or panel 14 supported an electrical grid 19 that was heated when subjected to electrical current flow through it, and by radiation uniformly heated the tank contents. One form that wall or panel 14 could take was that which was known in the trade as "Electriglas" (a radiant electric heater of the time). In such case, wall 14 could constitute a tempered glass panel, to one side of which was fused a chemical ceramic element

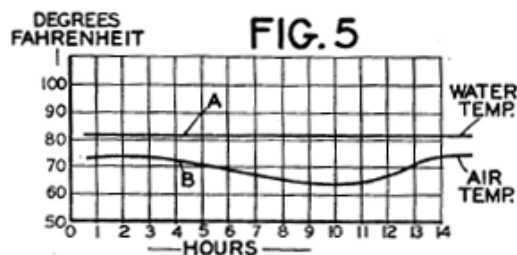
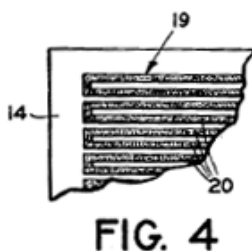
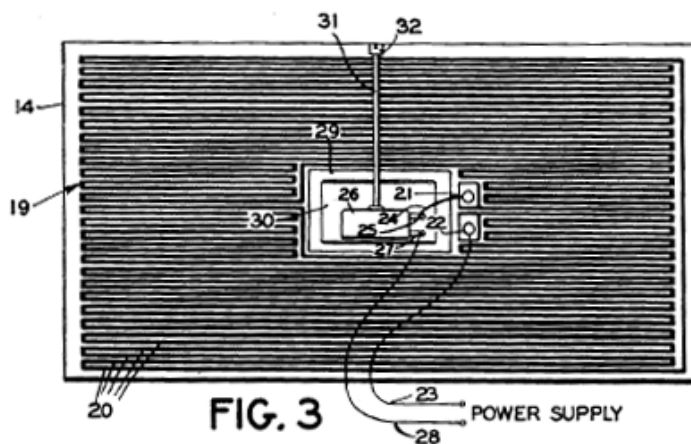
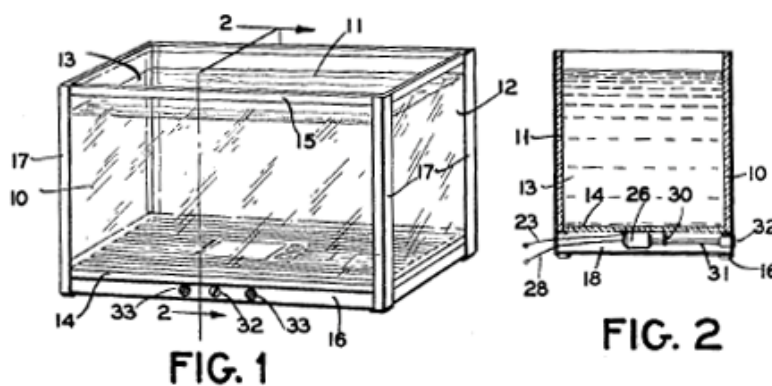

Figure 192: Charles J. Lumb, Jr.'s under-tank heating design, 1957.

defining electrical grid **19**. A second layer of glass was fused to that side of panel **14** having grid **19** thereon, thereby permanently protecting the latter against oxidation and deterioration.

As shown in Figure 4, grid **19** comprised a continuous heating element, covering substantially the entire area of panel **14**, and was arranged in a series of interconnected spaced parallel strips **20** with one end of the strip connected to a terminal **21** and the opposite end of the strip connected to a terminal **22** (Figure 3). Terminals **21** and **22** extended from panel **14** so that terminal **22** connected by way of a lead **23** to one side of a suitable source of current that could constitute a simple electrical outlet in a building, while terminal **21** connected by way of lead **24** with one terminal **25** of a conventional settable thermostat **26** arranged within chamber **18**. The opposite terminal **27** of the thermostat connected by way of a lead **28** with the opposite side of the electrical outlet.

While strips **20** of grid **19** covered substantially the entire area of panel **14**, they were so arranged as to define a clear area **29** that could be directly engaged by thermostat **26** or indirectly through a heat conducting bracket **30** suitably fastened to panel **14** within chamber **18**. The benefit of the clear area was that the thermostat could sense more accurately water temperature changes. The bracket supported an angularly displaceable rod **31** connected at one end to the thermostat and extending at its other end through bottom strip **16** where it accommodated a manually operable knob **32** by virtue of which the thermostat could be adjusted for a desired temperature to control current flow through grid **19**. In addition to rod **31**, bottom strip **16** could also accommodate two warning lamps **33** indicating passage of current through grid **19**.

If the tank was to accommodate tropical fish, for example, it may be desired to maintain the water temperature in the tank at substantially eighty-two (82°) degrees. Thermostat **26** was adjusted by way of manually settable knob **32** so that as soon as the temperature of the water becomes less than that desired, the circuit was closed by the thermostat in a conventional manner and current flowed through grid **19**, there-

by heating the latter. Heat radiation by panel **14** raised the water temperature whereupon the increased temperature was communicated to the thermostat to open the circuit when the desired water temperature had been achieved.

Actual tests conducted with the aquarium of the invention demonstrated that over a fourteen hour period the temperature of the water was maintained substantially constant in spite of substantial change (overnight) of ambient temperature. The actual recorded results were demonstrated graphically in Figure 5 where curve **A** represented the water temperature of the tank and curve **B** the ambient temperature.

[Figure 193, *Aquarium Feeding Device*, Number 2711714] A plethora of feeding schemes characterized this period and they varied from the simple to the complex. The simple designs start with that of Lawrence G. Timeus of New York City in 1955 (a ring-type floating feeder).

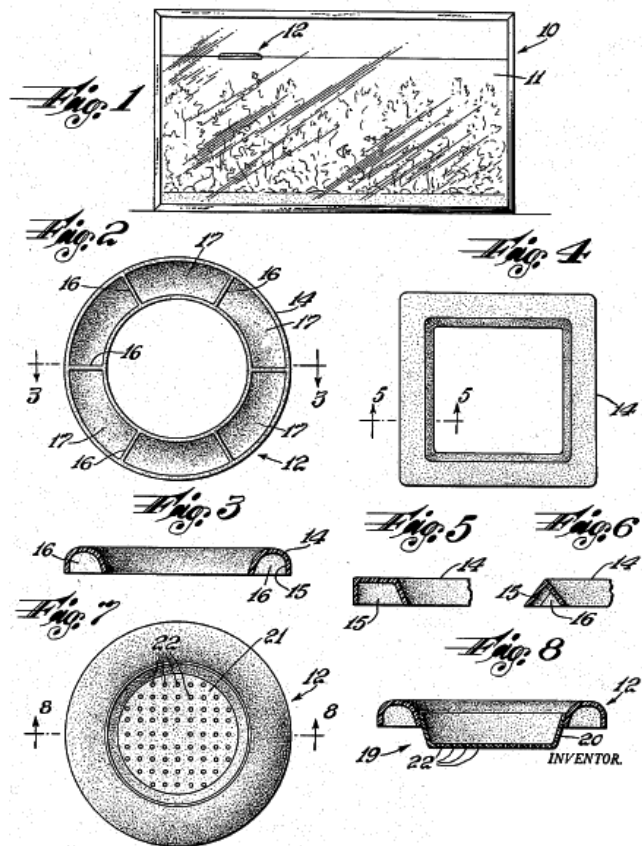

Figure 193: Lawrence G. Timeus' floating ring feeder, 1955.

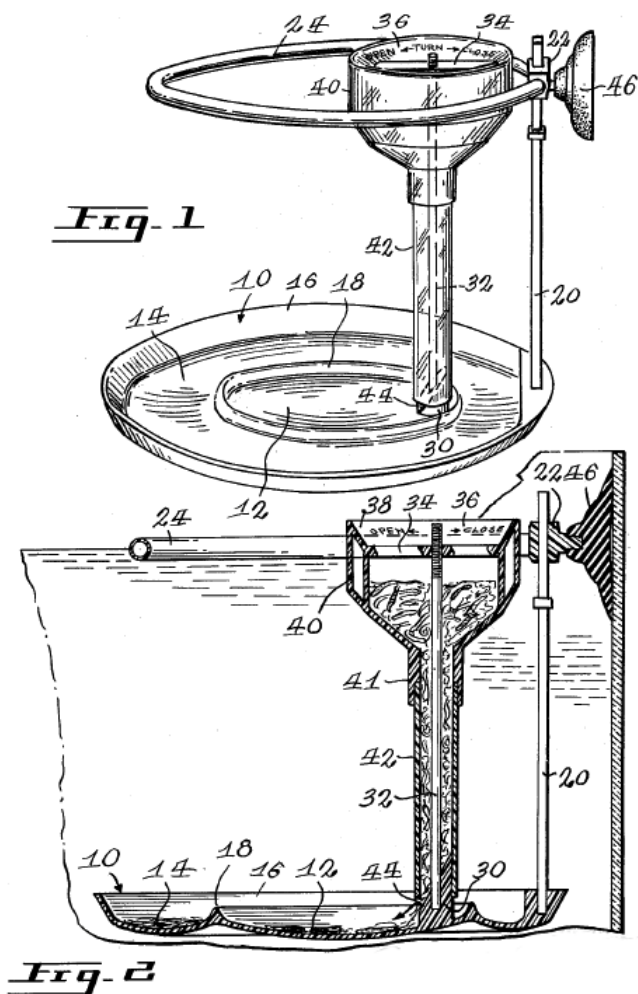

Figure 194: Constant G. Pettas's Funnel-fed ledge feeder, 1955.

Figure 1 is an elevation view, drawn to a reduced scale, of a household aquarium showing the frame member as it is used to feed dry food; Fig. 2 is a bottom view of the frame member; Fig. 3 is a cross-sectional view taken along the lines 3 - 3 of Fig. 2; Fig. 4 is a plan view of a frame member having a different configuration; Fig. 5 is a cross-sectional view taken along the lines 5 - 5 of Fig. 4; Fig. 6 illustrates an alternative cross-sectional contour of the frame member; Fig. 7 is a plan view of the dish member and Fig. 8 is a cross-sectional view of the dish member supported within the opening of the frame member shown in Figs. 2 and 3. The figures show and tell all about this simple invention.

[Figure 194, *Aquarium Feeder*, Number 2718211] Constant G. Pettas of Montreal, Canada in 1955 de-

vised a submerged ledge feeder). Figure 1 is a view in perspective elevation of an aquarium feeder in accordance with the present invention and Figure 2 is a cross sectional view of the construction shown in Figure 1 with the interior of the feeding chamber and food delivery tube being shown in more detail to more clearly illustrate the feeding action upon rotation. The figures show and tell all about this simple invention.

[Figure 195, *Aquarium Fish Feeding Station*, Number 2727489] Melvin Sklar of East Rockaway, New York in 1955 invented a submerged trough feeder. Figure 1 is a side elevation of the fish feeding device constructed according to the invention in an aquarium, the aquarium being partly broken away and partly in section; Fig. 2 is a front elevation of the feeding device in an aquarium, the aquarium being partly broken away; Fig. 3 is an enlarged fragmentary detailed section of a corner of the

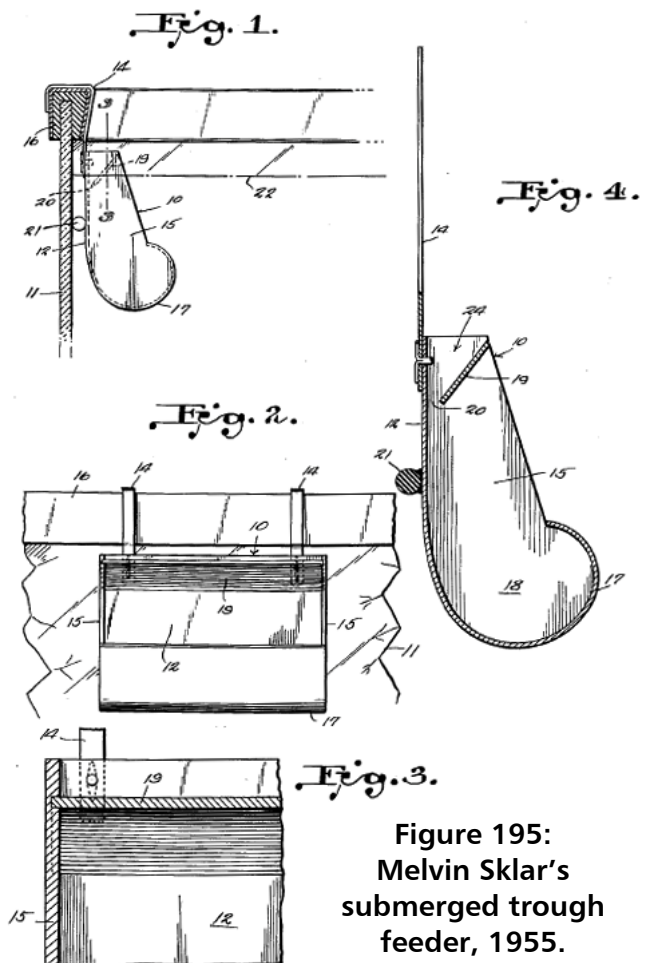

Figure 195: Melvin Sklar's submerged trough feeder, 1955.

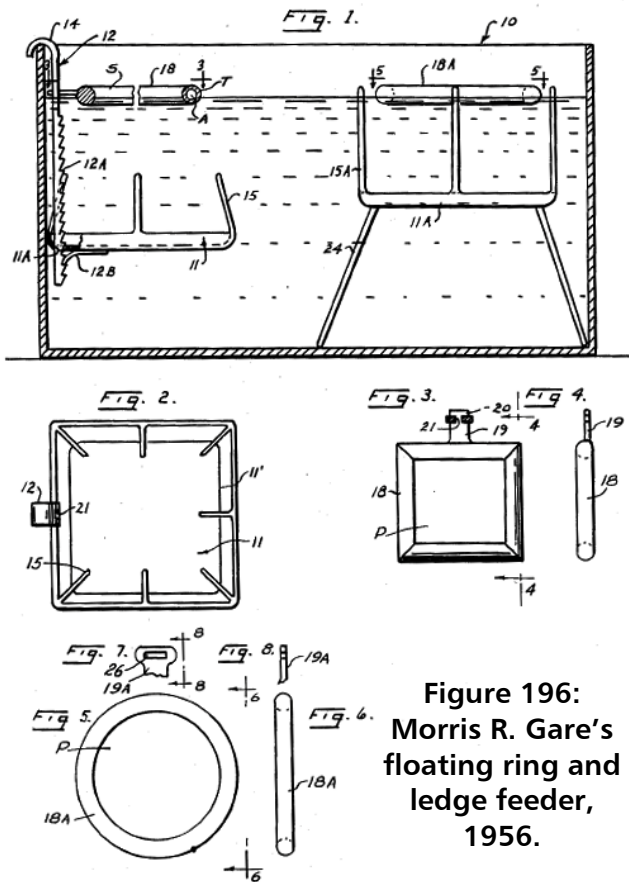

Figure 196:
Morris R. Gare's
floating ring and
ledge feeder,
1956.

device taken substantially on the line 3 - 3 of Fig. 1 and Fig. 4 is an enlarged side elevation in mid-section, of the feeding station of Fig. 1. The figures show and tell all about this simple invention.

[Figure 196, *Floating Aquarium Feeding Device*, 2754800] Morris R. Gare of Hillside, New Jersey in 1956 designed a floating ring combined with a submerged platform to catch uneaten food. Fig. 1 illustrates a side cross sectional view of an aquarium; Fig. 2 illustrates a plan view of a further embodiment of the feeding tray; Fig. 3 illustrates a plan view of the floating element taken on line 3 - 3 of Fig. 1; Fig. 4 is a side elevational view taken on line 4 - 4 of Fig. 3; Fig. 5 is a plan view of a further embodiment taken on line 5 - 5 of Fig. 1; Fig. 6 is a side elevational view taken on line 6 - 6 of Fig. 5; Fig. 7 illustrates a further embodiment of a stem element for retaining the floating element and Fig. 8 is a side elevational view taken on line 8 - 8 of Fig. 7. The figures show and tell all about this simple invention.

[Figure 197, *Floating Feeder Device for Aquariums*, Number 2761422] Frank H. Martin of San Francisco, California in 1956 invented a floating ring and a submerged platform to catch uneaten food. Figure 1 is a view in isometric projection showing, partly in cross-section, an aquarium appliance in place and in use in an aquarium; Figure 2 is an enlarged cross-section on a diametrical, vertical plane through the form of aquarium appliance as shown in Figure 1 and Figure 3 is a view comparable to Figure 2 but showing a modified form of the aquarium appliance. These designs were all aimed at keeping the fish food from floating all over the tank.

[Figure 198, *Time Operated Fish Feeding Device*, Number 2725852] The more complex designs were mechanical devices designed to feed the fish over a period of time when the aquarist was not

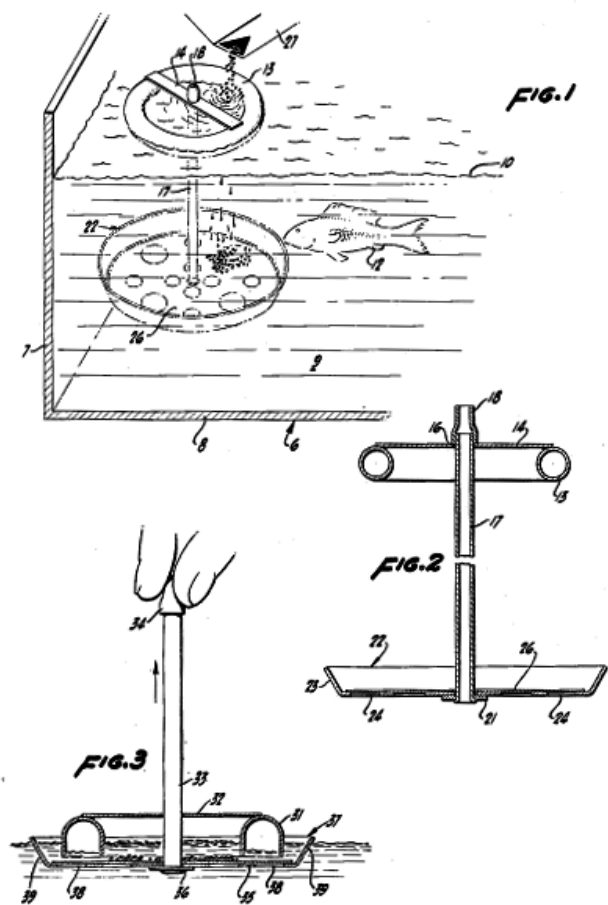

Figure 197: Frank H.
Martin's floating ring and submerged ledge
feeder, 1956.

available. The device patented in 1955 by Clarence H. Cramer of Toledo, Ohio featured a cylindrical hopper mounted on the side of the aquarium). The food was released by a valve at controlled intervals via a clockwork mechanism.

This automatic aquarium fish feeder comprised two units: the timing contactor and the electromagnetic feed dispenser (hereinafter called the dispenser). The timing contactor is illustrated by three views in the drawing, Figure 1, Figure 2 and Figure 6. It consisted of a standard self-starting electric clock movement to which a contactor was attached. The clock movement actuated the contactor every twelve hours. At such intervals the contactor made a contact that completed the circuit and caused current to flow through the interconnecting wires, **43** in Figure 6, to one or more dispensers.

The dispenser was illustrated in the drawings by four views: Figure 3, Figure 4, Figure 5 and Figure 7. It consisted of two food containers, Figure 4, **28**, for any kind of dry granulated and/or powdered material and Figure 3, **34**, for dry soluble pressed tablet material. Both containers were operated simultaneously by the same magnetic device and would dispense their respective materials until empty. The dispenser was mounted by a bracket **60** over the aquarium or on the edge of same in such a position that when it was actuated by an electric current from the contactor, it would eject a predetermined amount of its contents into the aquarium at that time. Any number of these dispensers could be connected to the contactor (limited only by the current carrying capacity of the contactor) and would operate at the same time, permitting a number of aquariums to be served with any variety of food or material. Also more than one dispenser could be used on an aquarium where

the size of the aquarium was large, or to satisfy special feeding needs.

Figure 1 shows a top view of the timing contactor with the cover, dial and sub-panel removed in order to show the inside mechanism. Figure 2 is a side view of Figure 1 with the left hand side of case removed to show internal construction. Figure 3 is a side view of the dispenser with the side container removed in order to show more clearly the internal construction. Figure 4 is a front view of Figure 3 with a panel cut away and showing the container attached. Figure 5 is a bottom view of Figure 3 show-

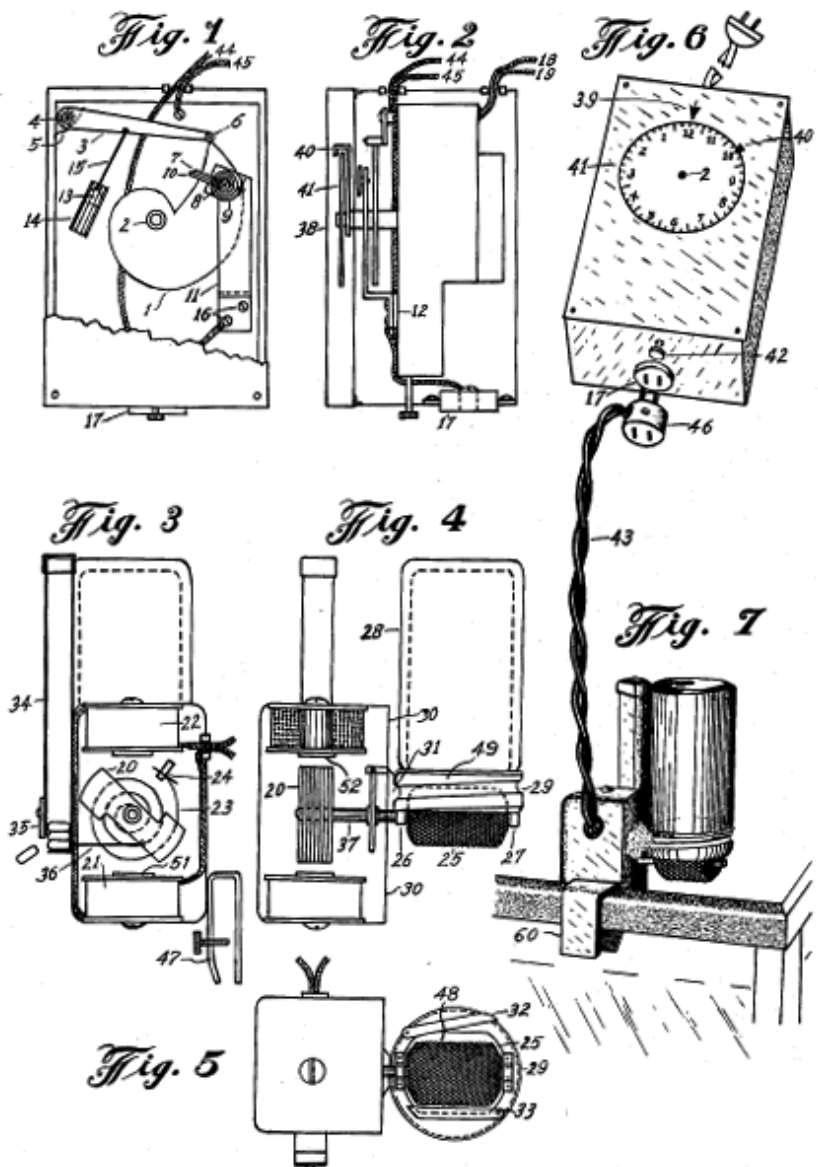

Figure 198: Clarence H. Cramer's hopper-type automatic feeder, 1955.

ing drum projections and gates. Figures 6 and 7 show an isometric view of a complete assembly consisting of one timing contactor Figure 6 with its cover removed and connected to one dispenser Figure 7 and mounted on the side of an aquarium. The cam 1 was pressed onto the hour spindle 2 of the clock in place of the usual hour band. Thus as the hour spindle rotated every twelve hours the cam also rotated. Contact arm 3 was pivoted at stud 4 and under tension of the torsion spring 5 that was also mounted on stud 4. As cam 1 rotated the contact, stud 6 rode to the top of the cam at which point it dropped to the low point on the cam as a result of the tension exerted by spring 5. As contact stud 6 dropped it made a momentary contact with spring contact 7 for approximately one-fiftieth to one-half second. The spring contact was pivoted at 8. The coil spring 9 held the contact 7 in the neutral position and returned it to neutral after it had been struck or displaced by the passage of stud 6 as it dropped from the high point on the cam. To the back of spring contact 7 and parallel with it was attached a piece of insulation 10. This was to prevent contact stud 6 from making contact when it was riding up on the cam.

Bracket 11 supported the whole spring contact assembly 7—8—9—10 and was mounted on the clock frame with two screws 16 but was insulated from it by insulator 12. A small piston 13 and closed cylinder 14 that comprises a sort of dashpot was connected to contact arm 3 by rod 15. Thus by virtue of the air escaping slowly past piston 13, the action of contact arm 3 was retarded so as to allow the 1/50th to a 1/2 second contact time that was required for proper operation of the dispenser. Part 17 was a standard female receptacle into which was plugged the stack up plugs 46 from one or more dispensers. Wires 18 and 19 were connected to the source of power. The feeder was not limited to any definite voltage because clock movement could be obtained for the various standard voltages, and the coils in the dispenser can be wound for any of the respective voltages which it was desired to use. In fact for small capacity feeders with possibly one or two dispensers attached, the clock could be plugged into the standard 115 volts A.C. outlet and the dispenser could be wound to operate from a simple low voltage door-bell transformer or battery. Thus the clock and dispenser

could be operated from different types of current or both from the same supply. Figure 2 is a side view with the pointer 40, the dial 41 and the cover 38 in place. Wires 18 and 19 connected to the proper voltage to run the clock motor. Wires 44 and 45 connected to the proper voltage to operate the dispenser.

Figure 3 is a side view of the granulated food part of the dispenser with the side cut away showing armature 20 and the two electromagnetic coils 21 and 22 having poles 51 and 52 that when energized by the proper voltage would attract the ends of the armature and cause it to be turned from the slanting position shown in the drawing to a vertical position. The coiled torsion spring 23 held the armature 20 in its slanting position of rest and returned it to the same position after operation. At stud 24 was an adjustment for positioning the armature. This adjustment also provided means to vary the length of arc (5° to 70°) that the armature 20 described during operation and that determined the quantity of food dispensed. Figure 3 also shows a side view of the tablet dispensing part of the dispenser 34 that consisted of a rectangular tube in which were stacked any food or other material in tablet form. An adjustment was provided at 35 for different thicknesses of tablets. The push rod 36 was connected to armature 20 so that when the armature moved into its vertical position a tablet was pushed out.

In Figure 4 the threaded support ring 29 was rigidly attached to the motor housing 30 at point 31 by soldering or welding. The armature 20 and drum 25 were rigidly attached to shaft 37 and rotated on bearings 26 and 27 on the support ring. The food container 28 had a threaded open bottom 49 at the end that was screwed into the support ring 29 and was removable for refilling.

Figure 5 is a bottom view showing the drum 25 in its proper position in the bottom of the support ring 29. Gates 32 and 33 were each pivoted at one end so that by moving them closer or farther away from the drum the openings at both sides of the drum could be varied in size so as to permit finer or coarser grades of food to be dispensed. The drum 25 was provided with projections or heavy knurling 48 on its surface to rake the food from the container as it rotated for-

ward and back during one cycle of operation describing a 5° to 70° arc.

In Figure 6, the dial 41 and rotating pointer 40 rotated with the hour spindle 2 of the clock. The rotating pointer was fixed permanently to the spindle but the dial was friction mounted so that it could be turned with the fingers. In order to set the clock for time of operation (feeding time) the dial was rotated until the desired hour number was directly under the pointer 40. To set for time of day the hand set 42 on the clock was turned until the desired hour number coincided with the index mark 39 on the clock panel. The clock dial 41 was hour numbered in reverse of a standard clock because of the rotating dial feature.

[Figure 199, *Fish Feeding Device*, 2772659] The device patented by Francis H. Tennis in 1956 also utilized a hopper mounted on the top frame of the tank and varied from the Cramer design mainly in the nature of the food release mechanism. Figure 1 is a vertical sectional view of the feeding device of this invention mounted on the wall of a fish tank; Figure 2 is a front elevational view of the Figure 1 device; Figure 3 is a view taken on the plane of the line 3 - 3 in Figure 1; and Figure 4 is a fragmentary sectional view showing a modified embodiment of a part of the device of Figure 1.

Referring to the figures, the numeral 5 designated generally a dispensing apparatus embodying the

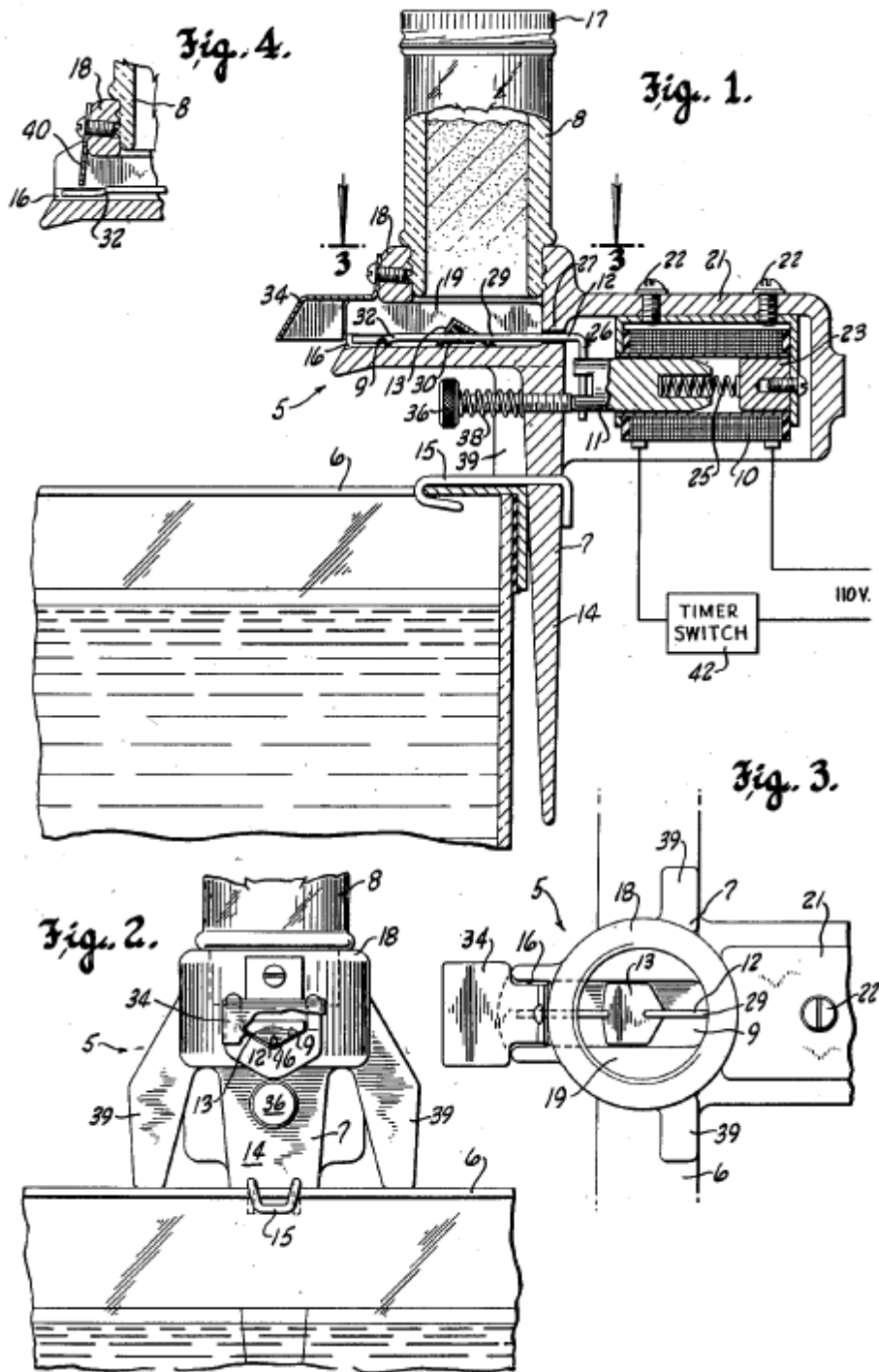

Figure 199: Francis H. Tennis' hopper-type automatic feeder, 1956.

principles of this invention and which was shown as comprising a fish feeder mounted on a wall of a tank 6. In general, the device comprised a substantially T-shaped body 7 on which the elements of the device were mounted and by which the device was held in place on a fish tank wall. On the body was a container 8 for fish food or other granular material opening

downwardly into a trough **9**, and a solenoid **10** having a reciprocable (i.e., capable of reciprocating) plunger **11** by means of which the device was actuated and which was connected by means of a link **12** with a movable pusher **13** in the trough.

More specifically, the body was formed as a unitary, substantially **T**-shaped member, comprising a unitary casting, and the stem **14** of the body comprised a bracket adapted to extend downwardly along the outside of a fish tank wall. A wire anchor hook or retainer **15**, one end of which was secured to the stem portion of the body, hooked over the tank wall to hold the device in place thereon. The anchor hook was fabricated from relatively soft wire so that it could be adjustably bent to permit the bracket to be secured to any type of fish tank or bowl. The trough **9** formed one side of the cross bar of the **T** body and was open at its end remote from the stem of the **T** to provide a discharge mouth **16** through which granular material from the container could transfer into the tank.

The container was made of glass so that the volume of its contents could be determined by inspection and it had a screw top **17** to facilitate filling it. Alternatively an inverted glass jar could be used, although this would necessitate removing the device from the fish tank each time it was filled so that the device could be inverted while the full container was attached right-side up. A collar **18** on the body was internally threaded to accommodate the correspondingly threaded lower end of the container and the interior of the container communicated directly with the trough through the feed passage **19** defined by the bore of the collar. The outlet of the feed passage was spaced inwardly from the mouth of the trough to prevent fish food from spilling out of the mouth of the trough at times when such discharge was not desired. The trough had a shallow **V**-shaped bottom so as to guide fish food from the container toward its open mouth.

The other portion of the cross bar of the substantially **T**-shaped body comprised a housing **21** for the solenoid **10** by which the device was actuated. In order to enable the solenoid housing to be formed integral-

ly with the remainder of the housing casting without the necessity for complex coring, the housing could be open at its bottom as shown. The open bottom of the housing was also desirable in that it promoted cooling of the solenoid under conditions where the solenoid was energized substantially continuously. The solenoid was mounted in the housing, with its axis substantially parallel to the length of the trough, by means of screws **22** extending through one housing wall into threaded holes in the solenoid frame. The axially slidable plunger **11** of the solenoid was reciprocable toward and from an end stop **23** comprising a part of the solenoid frame and toward which the plunger was attracted when the solenoid was energized. The plunger was biased away from its attracted position in any suitable manner as, for example, by means of a compression spring **25** reacting between the plunger and the end stop **23**.

The pusher **13** that served to expel granular material from the trough comprised a substantially roof-shaped member, the lower edges of which closely fit the bottom of the trough, as best seen in Figure 2. The link or rod **12** by means of which reciprocation of the solenoid plunger was transmitted to the pusher was **L**-shaped, and one leg **26** of the **L** extended downwardly through a transverse bore in the solenoid plunger at the end thereof remote from the stop **23** while the other leg **29** of the rod extended through a closely fitting aperture in the wall **27** that separated the solenoid housing from the trough and was secured to the pusher. The rod extended through the pusher as shown and a tightly fitting wedge **30** of rubber or the like interposed between the slanting sides of the pusher and the rod constrained the pusher to reciprocate with the rod and thus with the solenoid plunger. The connection between the rod and the pusher disposed the pusher adjacent to the outlet of the feed passage **19**. At its end remote from the solenoid the rod could be bent or displaced slightly as at **32** to enable it to break up adhesions between particles of granular matter as it reciprocated there through.

When the solenoid was energized and the plunger was drawn to its attracted position the pusher was likewise moved away from the mouth of the trough,

and upon de-energization of the solenoid the plunger would move abruptly in the opposite direction in response to the bias of the spring 25 thereon, thereby impelling the pusher toward the mouth of the trough so that the pusher would expel from the trough a quantity of the granular material therein. A deflector 34 spaced outwardly of the mouth of the trough prevented the granular material from being broadcast over an excessively large area as it was expelled from the trough and deflected it downwardly onto the surface of the water there beneath.

The quantity of feed that would be expelled from the dispenser at each cycle of operation thereof was determined by an adjusting screw 36 threaded through the stem or bracket portion of the body to have its inner end able to be engaged by the end of the solenoid plunger remote from the stop 23. As the adjusting screw was turned inwardly, the stroke of the solenoid plunger, and consequently of the pusher, would be shortened and therefore a lesser quantity of granular material would be expelled at each operation. A compression spring 33 reacting between the head of the screw and the stem portion of the body prevented the screw from creeping out of any position of adjustment to which it could be set.

To hold the screw above the upper edge of the tank wall on which the device was mounted, the body was provided with integral vertical ribs 39 spaced to opposite sides of the screw and the lower edges of which comprised downwardly facing abutments spaced beneath the adjusting screw and able to be engaged with the upper edge of the tank wall.

As an alternative to adjustment of the pusher stroke, a stripper plate 49 (see Figure 4) could be adjustably secured at the mouth of the trough to regulate the size of the aperture through which the granular material was expelled and thus control the amount of granular material dispersed at each operation. Since the stripper plate reduced the size of the orifice through which the material was expelled, there was less danger of widespread dispersal of the material with the stripper plate than without it, and consequently the deflector 34 was not necessary when the stripper plate was employed.

In operation, the container was filled with granular fish food and the device, with the container in place thereon, was mounted on the edge of a fish tank, the anchor hook 15 being bent as required to hold the bracket in place. The solenoid was then connected with a source of current through a time switch 42 of any of a number of well-known types, as, for example, a switch of the type by which a radio receiver was turned on and off at predetermined times. The timer could be arranged to energize the solenoid momentarily at whatever interval was determined to be desirable for dispensing food, or the timer could be of such type that the solenoid was normally energized and the flow of current thereto was momentarily interrupted at times when expulsion of food from the device was desired. In the latter event, of course, the device would consume current substantially continuously, but the resultant slight heating of the solenoid could be desirable in order to keep the granular material dry and thus prevent it from lumping.

[Figure 200, Automatic Fish Feeder, Number 2785831] In a design patented by Seymour Smolin of New York City in 1957, a housing containing the apparatus was fastened at the frame at one end of the aquarium. The upper portion of the housing block (Figure 3) was hollowed out for the food and the shaft had a notch in it to receive food when it was in the up position. When it was rotated to the down position, the food fell out at position 3. The rotor also had recesses at other positions to provide for a smaller quantity of food to be released for smaller or a fewer number of fishes. The motor (116) and control box (118) were located within the housing and were small.

Figure 1 is a perspective view showing an aquarium with the device mounted in position for use; Figure 2 is a longitudinal sectional elevational view taken through the device of Figure 1, substantially on plane 2 - 2 of Figure 1, the view being in fragment and showing the food regulating shaft fully retracted to the left so as to bring the larger dispensing recess into dispensing position; Figure 3 is a fragmentary sectional elevational view taken substantially on plane 3 - 3 of Figure 2.

An aquarium 10 was formed with a floor or bottom wall 12, usually of slate or other similar material, and surmounted by upstanding end walls 14 and 16, of glass, and side walls 18 and 20, also of glass. Metal moldings hold the glass and floor in position, forming upstanding molding comers 22, 24, 26 and 23, integrated with top and bottom moldings such as 30, 32, 34 and 36 at the bottom, and shown at 38, 40, 42 and 44 at the top. The moldings were joined smoothly together where they abut each other, to form a good solid strong frame for the aquarium. As seen best in Figures 2 and 3, the upper edges of the top moldings were folded at 46 closely over the top edge of the glass sides, such as 16, and folded inwardly downwardly at the marginal portion 48 so as to smoothly and firmly grip the glass. Suitable sealing composition, not shown, could be inserted between the glass and the frame moldings to further enhance the sealing effect against leakage of the water.

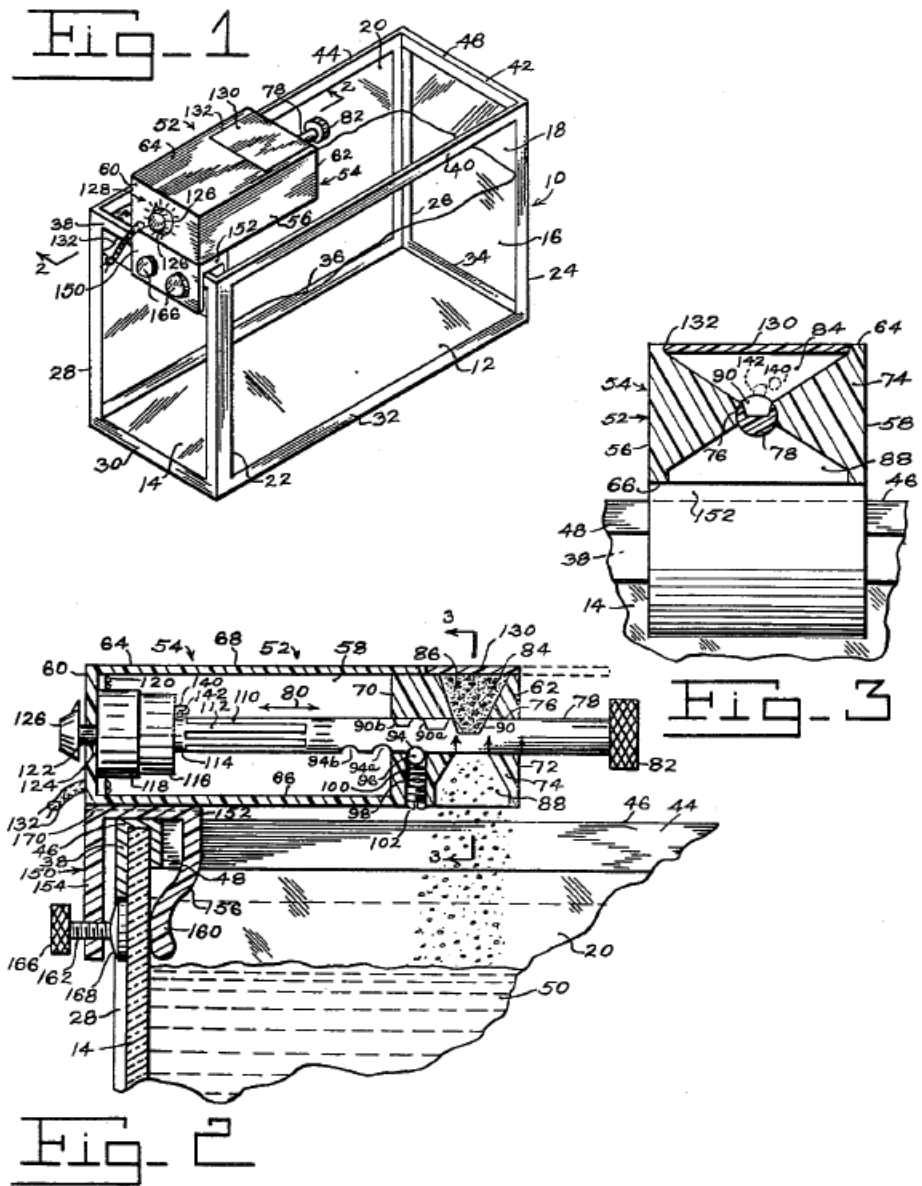

Figure 200: Seymour Smolin's notched shaft automatic feeding device, 1957.

In order to provide a continuous main supply of fish food from which a suitable portion was dispensed each day, mounted on the aquarium was a dispensing device indicated at 52. According to one preferred form of the invention, the dispensing and storage device included a housing 54, with side walls 56 and 58 secured to a pair of end walls 60 and 62, and also secured to top and bottom walls 64 and 66. There was thus defined within the housing 54 a chamber 68 to the left of wall surface 70 as seen in Figure 2, and to the right of wall 60.

The wall 62 was thickened to form between surfaces 70 and 72 a massive dispensing casing or block 74, which had a longitudinal bore 76 in which was journaled the distributor or dispensing shaft or rotor member 78 for both rotation and axial sliding motion in the directions of the arrow 80. A knob 82 was carried on the rotor distributor shaft 78 to enable it to be moved as desired. The upper portion of the dispensing block 74 was hollowed out to form an upper food storage and distributing hopper 84 to receive fish food in small particles or other forms, as seen at 86. At the bottom, the block 74 was also hollowed out to

form a guide passageway **38** to allow the food to drop downwards into the aquarium and onto the surface of the water **50** to be consumed by the fish.

A first dispensing cup or recess **99** was formed in the surface of the rotor **78**, as shown in Figures **1** and **2** and **3**, in intersecting underlying position relative to the open lower end of the hopper chamber or recess **84** so as to receive fish food in quantity sufficient to fill the cup **90** from the hopper when the rotor was turned so that the dispensing cup **90** was in uppermost position. The upper end of the distributing passageway **88** was also open but at the top in addition to being open at the bottom, so that when the rotor **78** was turned through one hundred eighty degrees to bring the dispensing cup **90** into a downwardly facing position, then the contents of the cup **90** fell by gravity force into the aquarium onto the water to feed the fish. By returning the rotor to its initial position with the cup **90** uppermost again, the cup **90** again filled with fish food and was ready for again being inverted to feed the fish on the next cycle, which was normally the next day.

Additional dispensing cups or recesses **90a** and **90b** were also formed in the rotor **78**, to one side axially of the larger cup **90**, these being graduated into smaller and smaller sizes, to take care of smaller fishes as needed, or fewer fishes. Locating hemispheres or recesses **94**, **94a**, and **94b** were also formed in the undersurface of the rotor **78**, as seen in Figure **2**, to receive the locating detent or ball **96** that was carried in a radial bore **98** in block **74**, with the ball **96** being biased radially inwardly by the spring **100**, and held in position by the threaded plug **102**. From this it was seen that to bring a smaller dispensing cup or recess, such as **90a** into position beneath the hopper **84**, it was only necessary to pull on the knob **82**, to the right, releasing the stop recess **94** from the ball **96** and bringing the shaft **78** over to the right until the ball **96** engaged in recess **94a** at which time the dispensing cup **90c** was in position to receive food from the hopper and dispense it to the aquarium. Similarly, to bring the smallest dispensing cup **90b** into dispensing position, it was only necessary to pull the knob **82** still further to the right in the same manner.

The left end of the rotor shaft **78** was formed with splines **110** which slidably engaged with matching splines **112** formed in the right hand end of the motor shaft **114**, of the motor or engine **116**. A control box **118** carried the motor **116** and in turn was carried by flanges **120** on the inside of wall **60**, being fixed against turning. A control shaft **122** extended out of the control box **118**, and penetrated through an opening **124** in wall **60** carrying a knob **126** on its outer end for turning therewith. Graduations **128** were formed or carried on wall **60** around knob **126** to indicate its angular position. Such graduations could indicate the time of day at which the fish were to be fed, or any other notation to guide the operator in setting the controls.

The splines inter-mating as seen at **119** and **112** in Figure **2** permitted the free movement of the rotor shaft **76** to the right or left as per the arrow **89** without movement axially of either the motor **116** or the control box **118**. A cover **130** was slidably carried in grooves formed in the margins of the opening **132** in the top wall **64** of the housing, so that the user could have access to the interior of the hopper **84** when desired, to inspect the quantity of food therein, or to add more, or remove some. The cover could also be made of clear plastic or glass, as seen at **130**, to permit inspection right through the cover without its removal to see how much food remained.

The motor **116** could be of any suitable small type, such as the type commonly used in powering electric clocks and timed mechanisms, being actuated by electrical energy supplied from a battery or the power lines through wires **132**. The motor was thus connected to the electric power lines through a switch inserted in the wires **132**, so that at a predetermined time each day, the switch was closed, allowing the motor to turn and thus rotating the shaft **78** once through a complete revolution only. The food in the recess **90** was thus dropped into the aquarium and the shaft or rotor turned to return the recess **90** back to its topmost initial position and then stopped. To accomplish this, the control box **118** contained an electric clock also actuated from the electric power lines and constantly turning at all times.

A micro-switch inside the control box **118** inserted in the circuit between the motor **116** and the wires **132**, was normally open and closed only when a cam in the electric clock works was brought into contact with the plunger of the micro-switch. When this cam contacted the plunger, the micro-switch was closed, turning on the motor **116** for one revolution. The micro-switch had an extension **140** that was in the path of the pin **142a** carried on and turnable with the shaft **114** of the motor **116**. The motor thus turned through one revolution, dumping the recess **84** of its contents and then when it returns to top position, the pin **142** tripped lever **140** and thus opened the micro-switch again, which opened the circuit to the motor **116** and stopping its motion. When the clockwork in housing **118** again the next day reached this same time, the micro-switch was again closed, allowing the turning of rotor **78** to dump the food into the water and, after one revolution, the pin **142** against lever **140** opened the micro-switch, and turned off the motor **116**.

In order to mount the device on the aquarium, there was provided a preferred form of bracket **150** that had a web **152** extending across the upper edge **46** of the molding of the aquarium frame. Walls **154** and **156** extended integrally downwardly from opposite sides of the web **152**, so as to come on opposite sides of the glass **14**. The lower portion of wall **156** was bent in at **160** to resiliently bear against the inner surface of the glass, and on the lower portion of wall **154** was provided one or more set screws **162** threaded through the wall **154**, with a knob **166** on their outer end and a suction cup **168** of rubber on the inner end of the screw to grip the glass surface. Turning the knob tightened the grip of the device and provided a firm mounting for the housing **52**. The housing **52** could be secured to the bracket web **152** or made integral therewith, and could be slidably removable if a dovetail groove **170** was formed in the web **152** and the lower portion of wall **66** of the housing was ribbed for engagement therewith.

The knob **128** could be employed to pre-set the cam position mentioned above as needed. The clockwork motor in housing **118** could also be constructed to turn the shaft **78** directly through the splines **110** and

112, omitting the use of the motor **116**, according to another form of the invention. As seen in Figure **2**, graduations in the form of upwardly pointing arrows could be shown on the shaft **78**, near or intended for registry with the outer portion of wall **62**, so that the particular size of dumping recess **90**, **90a** or **90b** that was in operative position could be ascertained readily by the user by inspection. To further condition the fish feeding operation to the fish themselves, the circuit could also include an electric bell, connected so that when the shaft **78** was turned to food dumping position and dumping the food into the aquarium, the circuit was completed through the bell so as to make it ring. The audible sound each day at feeding time would condition the fishes so that on hearing the bell they would know that it was feeding time, and would come for their food.

[Figure 201, Automatic Fish Feeder for Aquariums, Number 2808808] The creation of Edward C. Roben patented in 1957 had a hopper with a scoop (**45** in Figure 1) rotating at a constant rate of one or two revolutions per day. The scoop picked up the food as it rotated. A sleeve pushed the scoop arm out from the hopper and after it reached its highest point, would drop suddenly, striking the side of the hopper where the food would be discharged into the aquarium. The sleeve would retract the scoop and then continue on to its next rotation. Fig. 1 is an illustrative view of my fish feeder device and Fig. 2 is an enlarged detail view of a portion of the device shown in Fig. 1.

A hopper **1** containing prepared fish food particles **3** was secured by clamp **5** to a wall **7** of aquarium **9**. A rotatable shaft **11** was journaled between raised portions **13** and **15** on opposite sides of hopper **1**. One end **17** of shaft **11** was connected through reduction gears **19** to a driving motor **21**. Motor **21** and gears **19** caused the shaft to rotate at a fixed rate, for example one or two revolutions every **24** hours. A sleeve **23** positioned between raised portions **13** and **15** was secured to the shaft **11** and rotated therewith. This sleeve was free to move in an axial direction along the shaft. A spring **25** mounted concentrically about the shaft was interposed and compressed between the sleeve **23** and the raised portion **15**.

A connecting member 27 rigidly secured at one end of the sleeve 23 extended in a generally radial direction. The opposite end of this member was connected to a food cup or scoop 31. This scoop was closed at one end 33 and was open at the other end 35. A cam follower 37 connected at one end to connecting member 29 at a point intermediate its ends extended in a direction parallel to shaft 11. The other end of follower 37 rode on the contoured surface 39 of cam 41. This cam was secured to one side of the hopper in an area generally adjacent to the raised portion 13. Preferably, the cam and the hopper formed an integral unit.

As the shaft was rotated under the action of the driving motor, the cup 31 was swung through and about the hopper in a plane perpendicular to the axis of shaft 11. (The dimensions and relative positions of shaft 11 and hopper 1 were such as to permit arm 27 and cup 31 to be swung through a 360° arc.) As the cup was swung out of the hopper, the camming action began to further compress spring 25. The cup then traveled through the hopper and picked up a predetermined amount of food. As the cup left the hopper and attained a horizontal position, the cam follower was disengaged from the cam and the compressed spring suddenly expanded to a lesser degree of compression. This action forced the sleeve radial-

ly outward along the shaft until the sleeve contacted the raised portion 13 at which point the sleeve movement was stopped abruptly. Alternatively, the cam follower could contact the bent out portion of the cam to limit the movement of the sleeve in the same manner.

The cup was moved in the same radial direction and as the sleeve movement was suddenly stopped, the cup movement was also stopped abruptly. As a result, the food (which for example was in the form of quasi-gelatinous particles) carried in the cup was abruptly discharged onto the surface of the water 43 in the aquarium. A food agitator element 45 was further provided that for convenience was shaped to conform to the inner surface of the hopper. An additional connecting member 47 connected this element to the sleeve 23 at some convenient point, as for example at a point opposite the cup. Thus, as the shaft 11 was rotated, the agitator element served to stir the particles and prevent any food particles either from adhering to the surface of the hopper or from adhering to each other.

Electric power was supplied through leads 49 and a conventional switch 51 to a lamp 53 mounted on the side of the hopper adjacent the aquarium 9. This switch was secured to the hopper in such manner that

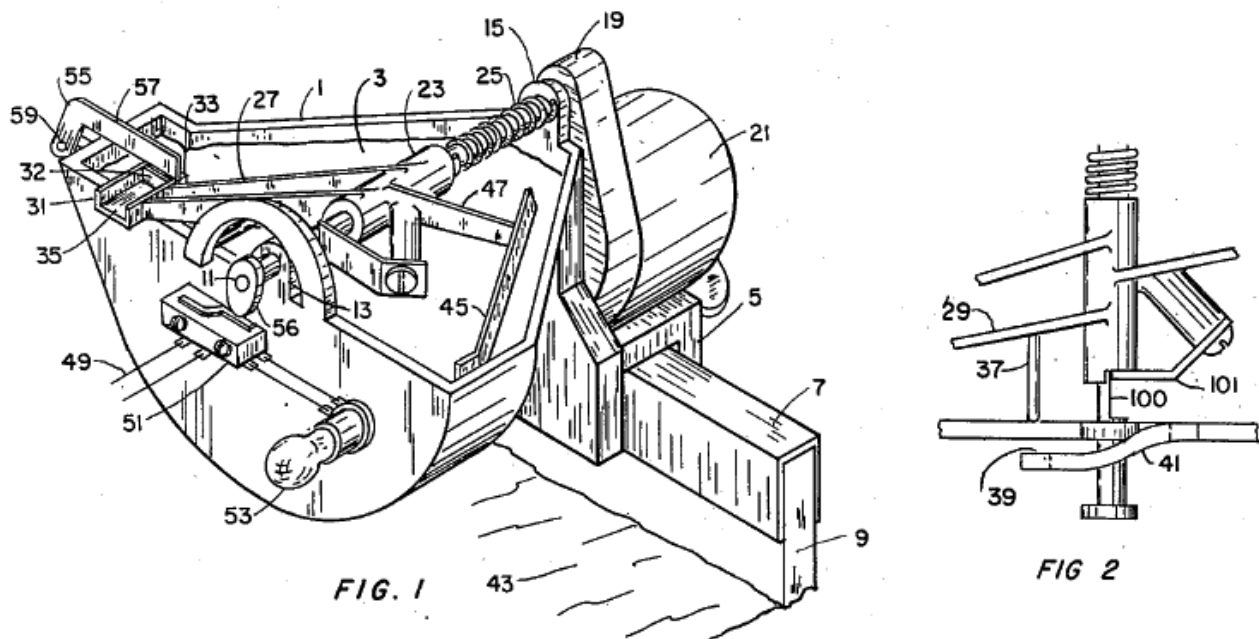

Figure 201: Edward C. Roben's scoop-hopper type feeder, 1957.

the switch was opened and closed through alternate engagement and disengagement with a cam **56** associated with the switch and attached to the shaft **11**. Thus, the lamp could be energized at desired intervals for given time periods. Good results were obtained by energizing the lamp for ten minute intervals in such manner that the lamp was energized for about five minutes before the food was supplied to the water and remained energized for about ten minutes thereafter. The end **32** of cup **31** could be moved to various positions within the cup so as to control the amount of food carried by the cup. Further a food level element, for example an L-shaped element **55** secured to the hopper could be used to remove excess amounts of food from the cup as the cup was moved toward the aquarium, thus insuring that all metered food quantities were substantially identical. Leg **57** of element **55** was pivoted about point **59** so that it could be moved out of the path of the scoop as it was swung upward. Leg **57** would then return to its original position through gravitational action.

Fig. 2 shows in detail the manner in which sleeve **23** was adapted to rotate with shaft **11** and at the same time was adapted to move back and forth axially along the shaft. A portion of the shaft **11** was cut away to leave a flatted section **100**. The sleeve was keyed to this flat portion by means of a key **101**. The sleeve projected forward of key **101** so that when the cup was moved forward, the sleeve (and not the key) struck the hopper.

[**Figure 202, Time Operated Fish Feeding Device, Number 2847066**] The device invented by Joseph P. Kleiber and Odif Podell of Pleasantville, New York in 1958 was quite simple (Figure 202-2847066), consisting of a round container containing a dispensing cup (36 in Fig. 5 in the diagram). As the dispensing cup rotated, it filled with food. When it got to the feeding spout (28 in Fig. 4), a spring abruptly snapped it sideways, throwing the food into the spout and dropping it into the aquarium.

Figure 1 is a perspective view of an aquarium with the automatic feeding device and aquarium light attached; Fig. 2 is a front elevational view of the feeding device; Fig. 3 is a side elevational view taken on

line **3 - 3** of Fig. 2; Fig. 4 is a cross sectional view taken on line **4 - 4** of Fig. 2; Fig. 5 is a cross sectional view taken on line **5 - 5** of Fig. 4 and Fig. 6 is a rear elevational view with the switch cover removed and a schematic circuit diagram shown.

Illustrated in Figure 1 is an aquarium **10** with a light **11** attached to the upper portion of the aquarium and an automatic feeding device **12** also attached to the upper edge of the aquarium by a spring clamp **13**. The feeding device was connected to a **110** volt source of electric supply by a cord **14** and the feeding device was in turn connected to the light **11** by an extension cord **15** that was plugged into a socket **14** in the feeding device **12**. Referring to Fig. 2 there is illustrated an elevational view of the feeding device **12**. On one face thereof there was a plurality of indicia representing a clock face. The clock face in this instance was divided into **24** hours rather than a **12** hour face and of course the rotating element would make one revolution in **24** hours. Although this embodiment was designed for one revolution in **24** hours, similarly the device could be designed for one revolution in **12** hours or two revolutions in **24** hours.

The feeding device **12** comprised a body member **18**. The member **18** was provided with a circular chamber **19**. The front face **20** of the circular chamber **19** was provided with an aperture **21** for a shaft **22** to extend through. Shaft **22** was at its other end connected by a friction element R to the drive shaft **22A** of motor **23**; shaft **22** and shaft **22A** made one revolution in **24** hours. On the clock face end of shaft **22** a knob and pointer element **25** was rigidly affixed to the shaft **22** to rotate with it, although due to the friction mounting it would permit adjusting or turning shaft **22** so that the pointer would register at any particular setting as desired. Also pivotally attached on shaft **22** and lying adjacent to face **20** was an adjustable window element **26** which did not turn with shaft **22**. There was an extended portion **26'** which was a part of arm **26**, portion **26'** generally conforming to the circular periphery of chamber **19** and would have a frictional bearing either with face **20** or the periphery of chamber **19** so that arm **26'** could be adjusted in a circular movement and retain a set position

which will be described later. The face 20 of body member 18 was also provided with a dispensing spout 27. The dispensing spout 27 was open on the bottom edge 28 and also provided with an aperture 29 on its upper edge, the aperture 29 being of the same size as arm 26 to permit arm 26 to pass there through. Member 18 was also provided with a removable cover 30 on its upper edge 31 so that the cover could be removed for filling the chamber 19 or partially filling the chamber 19 with feed.

Referring to Fig. 4, chamber 19 was provided with a rear wall 32. The rear wall was provided with an aperture 33 through which shaft 22A passed. The motor 23 was affixed to the wall 32 as illustrated in Fig. 4. Within chamber 19 there was a cam shaped ramp element 34 which could be attached to the inside of the front wall 20. The element 34 provided a cam face 35 for the feeding or dispensing element to bear against during its rotation. Also mounted within chamber 19 was a dispensing cup 36 (Fig. 5). The cup 34 was mounted on a rotatable spring arm 37,

the arm 37 being affixed to shaft 22 (Fig. 4). Referring to Fig. 6, the rear wall 32 of the member 18 could also support a switch 38. Switch 38 was mounted so that it was sufficiently spaced from the center of shaft 22 so that a rotating cam element 39 could be mounted on shaft 22 and for each rotation of shaft 22 the cam face 40 of the cam element 39 would bear against the actuating element 41 of switch 38. In this instance switch 38 was a micro-switch. Element 41 in the position illustrated in Fig. 6 would close switch 38. When cam 39 had rotated to the point where cam face 48 moved out of contact with element 41, element 41 being spring pressed outward would move into contact with the lower area of cam 39 and switch 38 would again open.

Referring to Figure 1 and Fig. 3, the 110 A.C. supply line 14 was connected to the motor 23 at its terminals 45 and 44 and in addition the A.C. was supplied to switch 38 and in turn through socket 16 to supply the necessary power for the light 11. However referring to Fig. 6 the terminals 45 and 46 were diagrammatic-

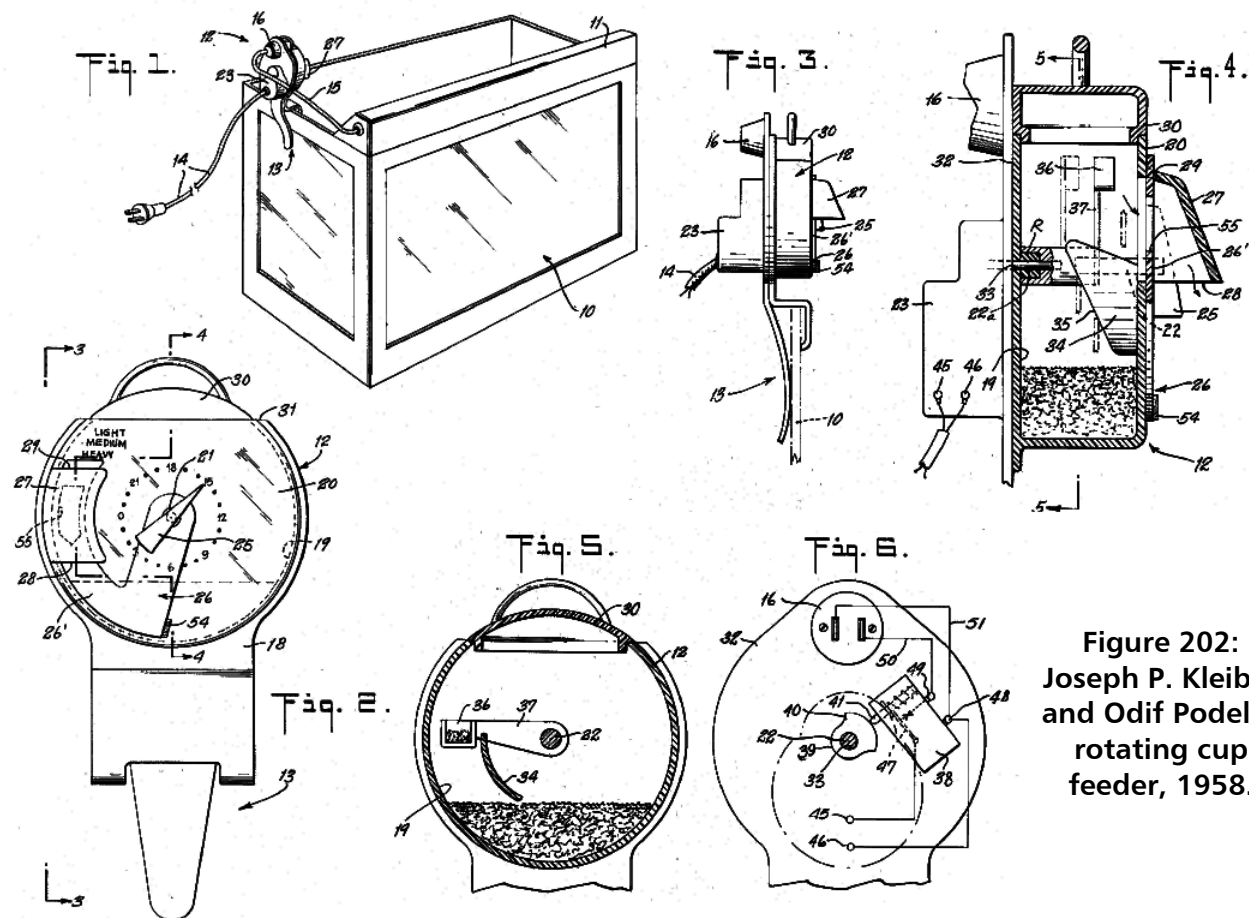

Figure 202:
Joseph P. Kleiber
and Odif Podell's
rotating cup
feeder, 1958.

cally illustrated as connected, that is, terminal **45** was connected to the switch element **47** while terminal **46** was connected to the terminal **48** of switch **38**. Element **47** in the position illustrated in Fig. 6 was shown as making contact with the stationary element of terminal **49** showing the circuit in its closed position. Terminal **49** was connected by a lead **50** to one side of socket **16**; the opposite side of socket **16** was connected by a line **51** to terminal **48**. Thus the circuit as shown in Fig. 6 was closed supplying the 110 A.C. to the socket **16**.

Referring to Figs. 2 and 3, there was illustrated a form of spring clamp **13** that was used to support member **18**. Referring to element **26**, Fig. 2 and Fig. 4, although this element was pivotally supported on shaft **22** it had to have a frictional engagement either as already mentioned or by affixing a rubber block **54** to arm **26'**. Arm **26'** was provided with an aperture **55**.

In operation it was apparent that the device had to be plugged into a 110 A.C. supply to operate the motor **23** and since the motor **23** was a synchronous motor, it would produce one revolution of shaft **22** for each **24** hours. The knob **25** permitted the rotation and adjustment of shaft **22** to any starting position, that is, the position of shaft **22** was with relation to the feeding arm. If a particular time of feeding was chosen, the feed arm **37** had to be in the position as illustrated in Fig. 5 for dispensing the feed. Therefore the setting of knob **25** would be adjusted to a position so that feed arm **37** reached the position illustrated in Fig. 5 at the desired time, keeping in mind at all times that arm **37** made one revolution in **24** hours as indicated by the indicia on face **28**. In the event a feeding was desired twice in a **24** hour interval, this could be accomplished as already suggested by using a **12** hour synchronous motor or as in this embodiment two arms **37** could be mounted in opposed relation on shaft **22** so that the feed would be discharged at the same time during each **12** hour period. Or in a still further variation, three arms **37** could be used as mounted on shaft **22** and spaced in a predetermined relation so that the feed was discharged during each **8** hour interval.

Referring to Fig. 4, feed cup **36** would be rotated in one complete revolution every **24** hours. The open face of the feed cup was on the dispensing side toward the front face **20**. As the feed cup **36** passed through the feed it picked up feed from the bottom of chamber **19**. As the spring arm **37** rose it would bear against the cam face **35** and cam face **35** would deflect spring arm **37** to the left (Fig. 4) until arm **37** reached the top of cam face **35**. As the arm **37** cleared face **35** due to its deflection when released, it would spring toward the right (Fig. 4) and this snap action would force all of the feed in cup **36** to be thrown through the window **55** of arm **26'**. The feed would thus be dispensed through the spout **27** dropping in a somewhat sprayed or spread out form through the aperture **28** onto the surface of the water of the aquarium. The arm **26'** could be adjusted (Fig. 4) to permit a complete clearance and the complete discharge of the feed from cup **36** or it could be moved slightly to partially cut off the discharge. Thus by regulating arm **26'** so that the top of the arm registered with indicia indicating maximum to minimum, the amount of feed in cup **36** to be discharged could be controlled. The front face of member **18** could be composed of a clear plastic so that the amount of feed in chamber **19** could be watched and thus replenished when necessary.

[**Figure 203, Automatic Fish Feeder, Number 2858799**] The design of Alexander and Randolph Kraus of New York City in 1958 was a real Rube Goldberg (Figure 203-2858799). The design consisted of a tower containing a removable inner cylinder open on one side containing a number of trays holding the food. A motor run by a timing mechanism dropped the tower near the water surface where the food was blown into the water by an air pump that was part of the design. When all of the trays had been lowered into the water, the inner cylinder was removed and dried, and the food was replaced. Although the device also could control the timing of the aquarium lights – a nice touch – all in all it was a featherbrained idea.

Fig. 1 is a perspective view of an aquarium having removably attached a fish feeder embodying the invention; Fig. 2 is a sectional view taken along the

line 2 - 2 of Fig. 1; Fig. 3 is a sectional view taken along the line 3 - 3 of Fig. 2; Fig. 4 is a sectional view taken along the line 4 - 4 of Fig. 2; Fig. 5 is a sectional view taken along the line 5 - 5 of Fig. 4; Fig. 6 is a perspective view of the outer or guide tube or cylinder from a part of the invention; Fig. 7 is a perspective view of the food container or inner tube or cylinder forming a part of the invention; and Fig. 8 illustrates in side section three forms of shelves for carrying food, the shelves to be mounted on the inner cylinder of the device.

Because this invention had too many fatal flaws and because it was a mechanic-electric device with detailed descriptions, I have opted not to cite the inventor's description save for the following short piece dealing with its operation.

In operation, feed preferably of the dry type was normally placed upon the shelves 46 carried by the inner tube 38 and thereafter the inner tube was inserted

into the outer tube. The inner tube was slightly longer than the outer tube to permit the inner tube to extend a small distance below the outer tube. With the parts so arranged, the outer tube was disposed within the aperture 32 in plate 30 so as to bring the worm wheel 54 into meshing relation with the worm 64. However in order to effect this meshing engagement of the gears, the slot 88 had to be so positioned that the pin 86 was disposed therewithal whereby the pin and slot prevented rotary movement of the carrier 38 relative to the outer tube 34. Motor 78 was then energized to begin driving the carrier downwardly as before described and this movement would continue until the uppermost shelf had been immersed in the water in the tank. Rack 48 was arranged so that it terminated a short distance from top of the cylinder 38 and the remaining length of cylinder was provided with a slot 92. When the carrier had moved downwardly sufficiently, the worm wheel 54 moved out of meshing relation with the rack 48 and became disposed in the slot 92 where it could not effect any fur-

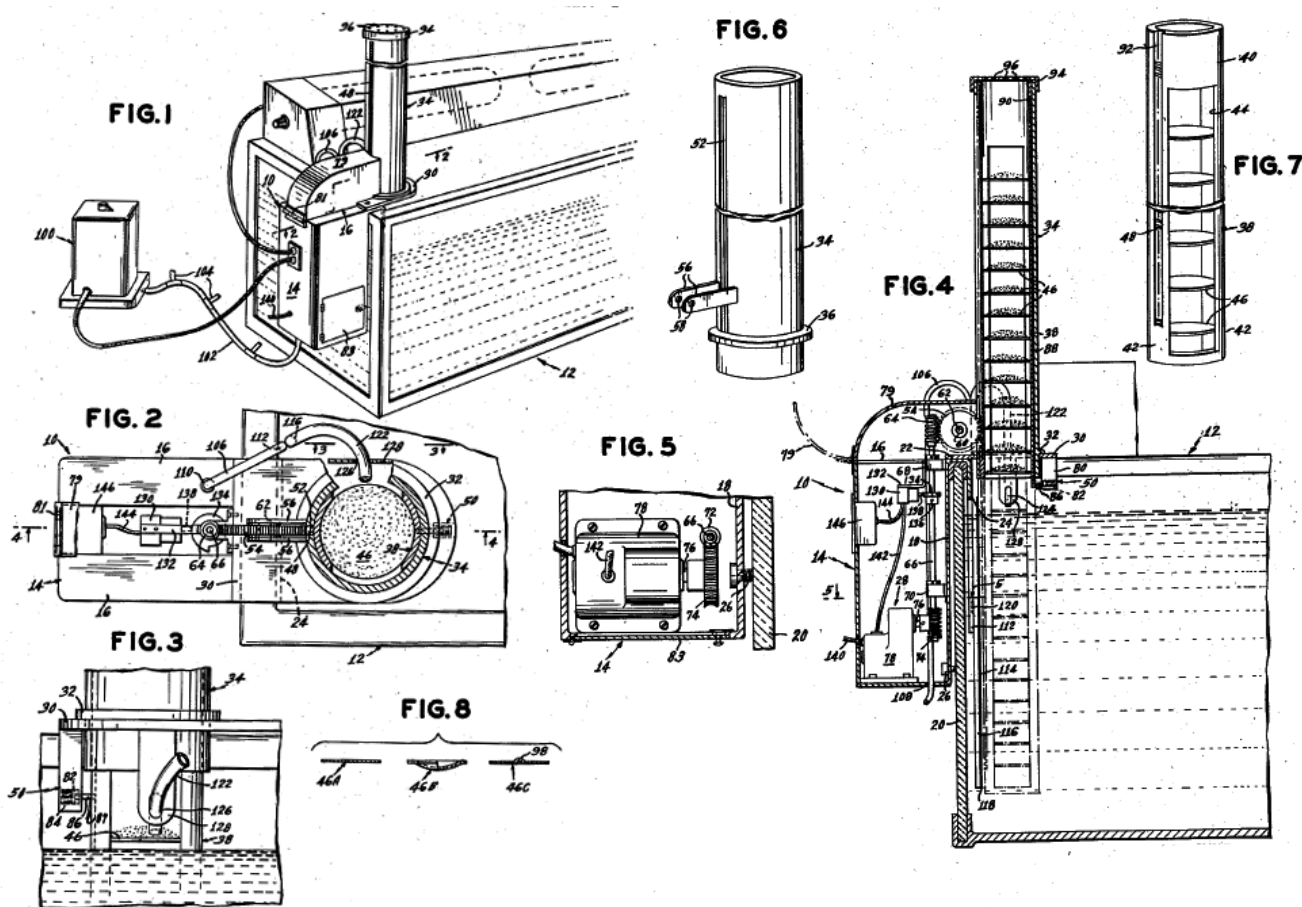

Figure 203: Alexander and Randolph Kraus' ratcheting tower feeder design, 1958.

ther movement of the inner tube. Accordingly, the inner tube was free to move downwardly under the influence of gravity without interference from the gears. As this downward movement commenced, however, pin 86 moved into the depression 90 at the end of the slot 88 to thereby lock the inner cylinder against any further downward movement, and thereby preventing the cylinder from dropping off into the aquarium.

Because of their expense, automatic feeders are not an option when a large number of tanks are involved. When one thinks about it, one is perfectly safe in leaving one's fishes unattended for a week or even two, and if push comes to shove a far simpler solution is just to have a friend or family member stop by every three or four days to feed your fish (if they know nothing about feeding fish, you can prepare servings in small packages ahead of time). Fortunately, today's automatic designs are simpler and more reliable, so for the aquarists who have only a few tanks, they may be a reasonable option.

[Figure 204, *Aquarium Tank Construction, Number 2713847*] In 1955, Richard H. Blaise of Glendale, California patented an aquarium that came in the form of a kit, the frame being packaged in a knock-down form. Blaise cited the fact that the smaller sized aquariums were heavy and therefore costly to transport, and that the danger of the glass breaking during shipment was great. His idea was to manufacture a frame that the aquarist could put together readily and then glaze it himself with glass purchased locally. The frame was of an interlocking type so that no bolts or other fasteners were needed. The package came with aquarium cement – the aquarist didn't have to purchase it. This was a well-thought out idea, but the fact was that the already pre-built smaller aquariums available in stores were cheap enough to overcome the presumed cost advantage.

Fig. 1 is a perspective view of an aquarium embodying the invention; Fig. 2 is an enlarged transverse, sectional view taken on the line 2 - 2 of Fig. 1 and Fig. 3 is an exploded, perspective view of the component parts of the aquarium.

The embodiment of the invention comprised a frame structure 1 including a bottom frame member 2, a top frame member 3 and vertically disposed corner members 4, 5, 6 and 7, end panels 8 and 9, side panels 10 and 11, and a bottom panel 12, all of the panels being preferably formed of glass. Additionally, the structure included a layer or coating of sealing putty 13 on all surfaces of the frame structure adjacent to the glass panels.

The bottom frame member 2 was formed from sheet metal (preferably but not necessarily, zinc) and was first formed as a flat, hollow rectangle having corner forming notches cut in the exterior corners. The outer portion of the flat blank was then bent at right angles along a line about at the mid width of the side and end portions with the resultant formation of upstanding side flange portions 14 and 15 and end flange portions 16 and 17. The top frame member 3 was similarly formed from sheet metal with depending

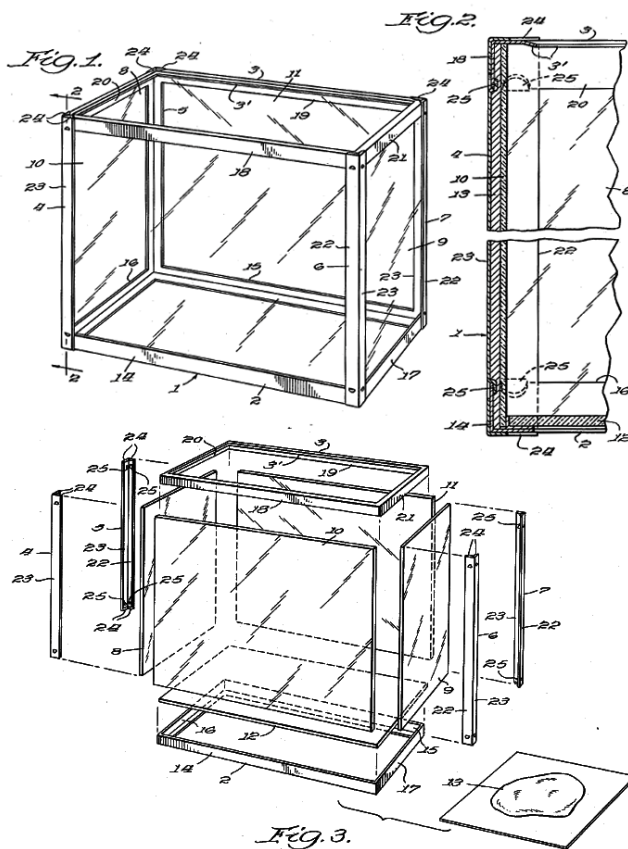

Figure 204:
Richard H. Blaise's aquarium kit, 1955.

side flange portions **18** and **19**, and end flanges **20** and **21**, the inner edge **3** being slightly in-turned.

The four corner members were identical and a description of one will suffice for all. Each corner member was formed from sheet metal strip bent at right angles along a medial longitudinal line to form side flange portions **22** and **23**. The opposite ends of the strip were provided with a centrally disposed V-shaped notch and the resulting end tabs **24**, **24** being bent inwardly to form partially closed ends for each corner member. Additionally each flange portion at each end was provided with an inwardly projecting tongue **25** disposed from the end tabs **24** a distance slightly greater than the width of the flange portions of the top and bottom frame members.

The complete kit comprised the five panels, the top and bottom frame members, four corner members and a quantity of sealing putty. In packing, the two side panels could be placed in a box and the frame members nested together and placed on the side panels; the fact that the bent flange portions of the top and bottom frame members were not connected at the corners permitted such nesting with a minimum of distortion. The bottom panel was placed within the frame members and the end panels were placed on the bottom panel. The corner members were placed alongside of the nested frame members and the necessary quantity of putty enclosed in a suitable flexible plastic casing and formed into a thin flat elongated mass was placed on the top of the side panels. Suitable paper was placed between all adjoining glass surfaces.

In this form, the component parts of the aquarium could be enclosed in a box having about one fourth the cubic space that would be required for a properly packed, completely assembled aquarium. Further, the manufacturer had not been subjected to assembly expense and the risk of shipment was greatly reduced, all these factors resulting in a greatly reduced cost and consequent greater appeal to purchasers. Still further, since there had been no assembly, the consequence of returned merchandise for defective construction deriving from leaks was completely eliminated. The fact that this common cause for

complaint was eliminated and the ease of storing and delivering the merchandise in this kit form both made the item extremely attractive to merchants.

To set up the aquarium from the kit materials, the top and bottom frame members **2** and **3** were first inspected to be sure that the flange portions were at right angles to the inner or side portion thereof and, if necessary, the flange portions were bent inwardly until the ends were in alignment at the corners. The corner members are then applied to the outside of the corners of the frame members and secured by bending down the tongues **25** over the edges of the flanges of the frame members as best shown in Fig. **2** with resultant formation of the frame structure **1**. The sealing putty was then applied in smooth even layers on all inner surfaces of the frame structure except the underside of the inner flange portion of the top frame member or, in other words, on all surfaces of the frame structure having a panel supporting function. The side panel members were of a size closely fitting the layers of putty applied to engage the bottom and end panels and were first applied to the frame structure by being pressed against the putty lining the engaged inner surfaces of the corner members and frame members.

The end panels were of the same height as the side panels, but in width fit between the sides of the side panels and were next similarly pressed into position against the putty lining the end flanges of the top and bottom frame members and the adjacent portions of the corner members. Lastly, the bottom panel was pressed into position, thus serving also to hold the bottom edges of the side and end panels against inward displacement as the end panels correspondingly served to hold the side panels in place. Finally, any extruded portions of the putty projecting between the edges of the panels or protruding beyond the edges of the frame structure on the exterior of the assembly was removed and the assembled aquarium was ready for testing for leaks and upon completion of testing and any indicated further sealing, was ready to be put into use.

[**Figure 205, Aquarium, Number 2787981**] Two patents were awarded during 1957 that featured cosmetic improvements on aquarium design. Benjamin

Landesberg of Philadelphia was issued a patent for a marine aquarium that incorporated a panel at the bottom to conceal the obtrusive filtering apparatus typical of the marine aquaria of the day. In the inventor's own words,

“My invention relates to an aquarium and particularly to an aquarium whose sides are partially of metal and partially of transparent panels. An object of my invention is to provide a panel wherein the bottom, which may hold suitable filtering materials, will not be apparent to one viewing the marine life within the aquarium. Another object of my invention is to provide an aquarium wherein the bottom and a portion of the side walls are integrally formed together, and wherein a flange formed with the side supports the transparent panels. It is another object of my invention to provide an aquarium wherein the parts may be quickly assembled and readily disassembled and the transparent panels may be readily taken apart.”

Figure 1 is a perspective view of an aquarium embodying the invention; Fig. 2 is an enlarged sectional view taken along the line 2—2 of Fig. 1; Fig. 3 is an enlarged sectional view taken along the line 3 - 3 of Fig. 1; Fig. 4 is an enlarged fragmentary sectional view taken along the line 4 - 4 of Fig. 1; Fig. 5 is an enlarged fragmentary view of the corner post and the inwardly projecting flange and Fig. 6 is an enlarged fragmentary view of the completely assembled corner post, metal molding, and the caulking compound, as well as the plastic compound holding the transparent panels in

place and making the junction of the panel and the flange watertight.

The fish aquarium embodying the invention comprised a sheet metal lower section, designated as A, and an upper transparent enclosure designated as B. The lower section A was formed from a single sheet metal stamping and comprised a bottom 10, a pair of vertical end walls 11 at right angles to the bottom

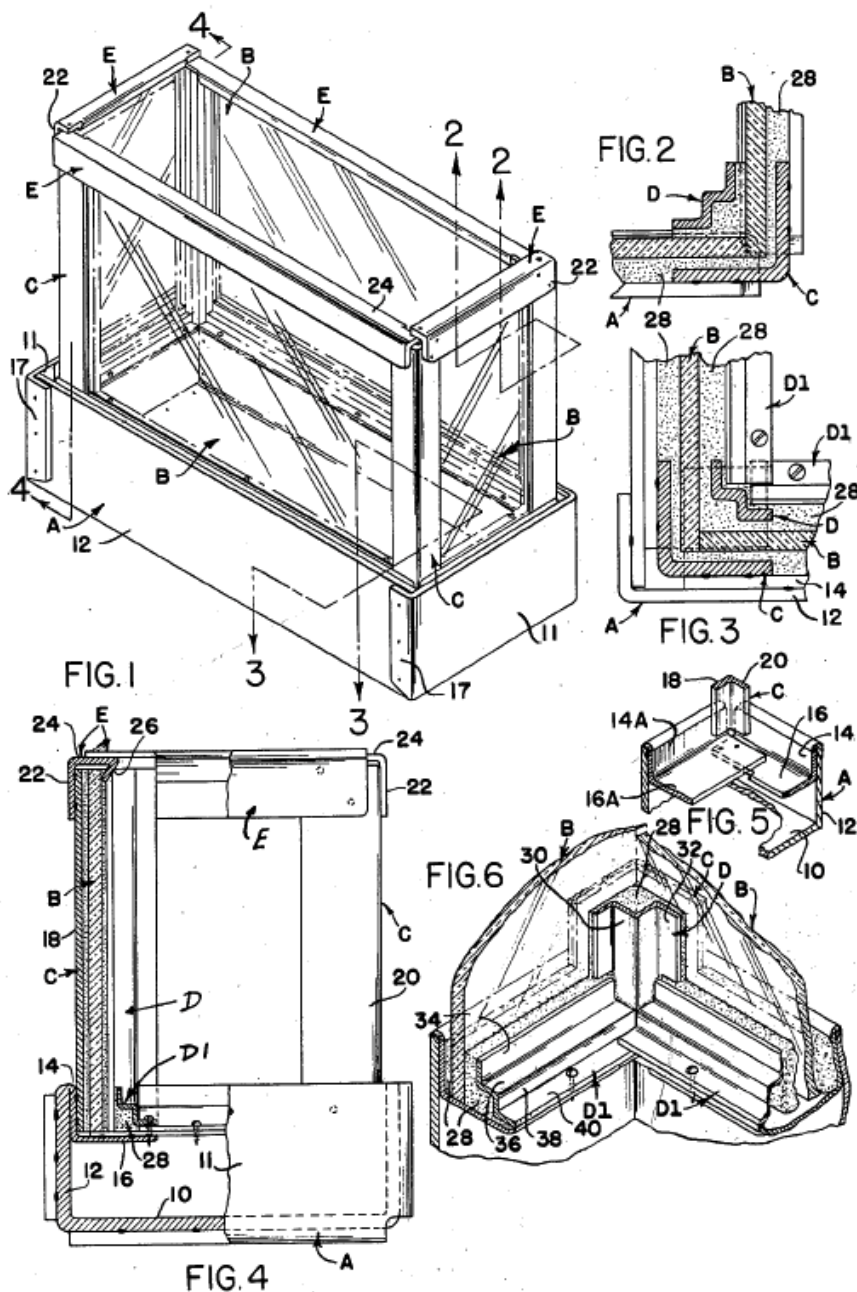

Figure 205: Benjamin Landesberg's Marine aquarium heating, aeration and filtration concealment design, 1957.

and a pair of vertical side walls **12** at right angles to both the bottom and end walls to define four trihedral corners.

Each of the side walls **12** had an interior upper portion **14** that was folded parallel to and abutted the side wall itself. The interior upper portion **14** terminated in a horizontal flange **16** that extended inwardly at right angles to the side wall and was adapted to support vertically extending transparent panels **B** of the upper enclosure. Each of the end walls **11** had a pair of flaps **17** that was rigidly secured by spot welding to the end of the adjacent side wall **12**. Each of the end walls **11** had, in addition, an upper interior portion **14A** that was folded parallel and abutted the upper portion of the end wall itself. The upper portion **14A** was further folded to form a horizontal end wall flange **16A** that extended inwardly at right angles to the end wall **11**.

The adjacent ends of the horizontal side wall flanges **16** and the end wall flanges **16A** overlapped and were secured to each other by spot welding to form four trihedral support corners with the interior portions of adjacent side and end walls. These trihedral support corners provided a foundation for vertically disposed corner posts, generally designated as **C**. The corner posts **C** were angle members having legs **18** and **20** that supported adjacent edges of the transparent panels **B** in a rectangular configuration. These panels **B** could be made of glass or suitable plastic. The bottom edges of the corner posts **C** were supported within a respective trihedral support corner while the panels **B** were supported upon the inwardly projecting horizontal wall flanges **16** and **16A**.

A horizontally extending angle member or bezel, designated as **E**, joined the upper ends of the vertical post **C** and also provided a lateral support for the transparent panel **B**. The horizontally extending metal molding **E**, or bezel, had a vertical leg **22**, a horizontal leg **24** and downturned lip **26**. The vertical leg **22** was adapted to abut against the upper portion of the corner posts **C**, and the lip **26** was adapted to abut in contact with the transparent panel **B**. The transparent panels **B** were sealed along their adjacent vertical edges by sandwiching a layer of mastic **28** between

the corner posts **C** and a **W**-shaped molding strip, designated as **D**. A bead of mastic was laid at the interior portion of the juncture of two panels, the mastic being supported by the molding strip **D** as is more fully described below. Each of the molding strips **D** comprised a pair of laterally extending arms **32** integrally formed at right angles to one another by a laterally extending right angle step **30**. Molding strips **D1** were set in a horizontal position and were also **W**-shaped in cross-section wherein a pair of laterally extending arms **34** and **40** at right angles to one another integrally extended from a laterally extending right angle step having members **36** and **38**.

A layer of mastic **28** was laid between the anterior base of the panels **B** and the interior upper portions **14** and **14A** of the end and side walls, and a bead of mastic was laid between the molding strips **D1** and the interior base portion of the panels **B**. The panels **D1** were permanently affixed to the horizontal flanges **16** and **16A** along the arms **40** by suitable means such as by riveting or bolting. Mastic was sandwiched between the arms **40** and the flanges **16** and **16A** along the entire length of the molding strips. The ends of the horizontal molding strips **D1** abutted one another at each of the trihedral support corners and defined a pyramidal corner having tri-planar steps with the end of a vertical molding strip **D**. Thus, a seam of mastic was sandwiched between each of the molding strips and its adjacent surfaces to provide a seal along the entire lower internal periphery of the panels **B**, along the juncture of the abutting edges of the panels and at the corners of the upper enclosure where it was set within the lower section **A**. The inside vertical molding post **D** had mastic **28** between its legs **30** and **32** to seal the juncture of the transparent panels **B**. The inside horizontally extending molding posts **D1**, similar in construction to post **D**, had legs **34**, **36**, **38** and **40** between which was laid mastic **28**.

[**Figure 206, Aquarium with Sealed and Packed Joints, Number 2792811**] In the same year, Joseph Di Chiaro of New York City designed an aquarium whose frame had rounded corners, giving it a decidedly different and rather modern appearance. The principal object of Di Chiaro's invention was to provide

an aquarium which could be manufactured and assembled in a simple and convenient manner from a relatively small number of separate parts. Another object was to provide an aquarium that was sturdy in build and pleasing in appearance. One feature of his invention resided in the provision of top and bottom frame members each consisting of a pair of U-shaped parts with rounded corners, in combination with four corner posts of round-back stock defining a rectangular case with gently rounded edges. Another feature was in the provision of bent-over edges at each of the frame members and corner posts, these edges being in contact with the wall elements of the tank to form chambers adapted to receive a sealing compound that held the wall elements in place.

Figure 1 is a perspective view of an aquarium embodying the invention; Fig. 2 is an enlarged plan view of piece of metal stock designed to form one of the frame halves of the aquarium of Fig. 1; and Figs. 3, 4 and 5 are enlarged sectional views taken, respectively, on the lines 3 - 3, 4 - 4 and 5 - 5 of Fig. 1.

The tank or aquarium 10 shown in the figures comprised four corner posts 11, 12, 13 and 14 whose quadrantal cross section was best seen in Fig. 3; an upper frame consisting of U-shaped halves 15 and 16; a lower frame consisting of similar halves 17 and 18; a bottom plate 20 made of slate; and four glass panes 21, 22, 23 and 24.

Each of the four corner posts 11-14, as particularly shown for the post 11 in Fig. 3, was provided with inwardly bent edges or flanges 25 and 26 that made contact with the adjacent glass panes (here the panes 21 and 22) to form pockets or chambers enclosing a sealing compound 19, such as putty or mastic. Similar pockets were

formed by the upper frame members, as shown in Fig. 5 for the member 16 whose edges 27, 28 touched the pane 24 from opposite sides, and also by the lower frame members, as illustrated in Fig. 4 where the member 17 was shown provided with edges 29, 30 engaging the bottom plate 20 and the pane 21 respectively.

Fig. 2 illustrates how each of the frame members 16-18, in particular the rear upper frame half 16, was formed from a piece of channeled stock designated 16'. The flange portion of the stock was cut away at the locations of the tank corners, as indicated at 31,

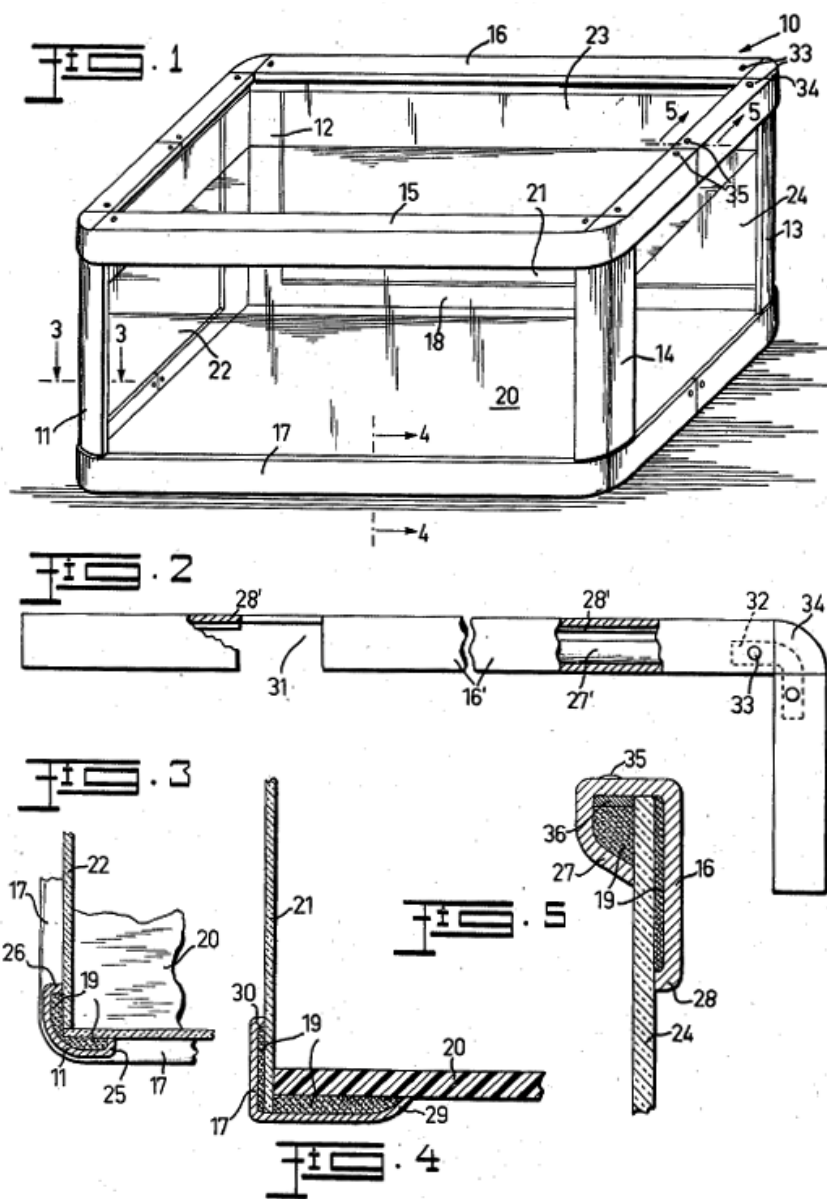

Figure 206: Joseph Di Chiaro's rounded corner design, 1957.

and the stock was then bent as shown in the right-hand portion of Fig. 2; the two legs thus formed were secured in their relatively perpendicular position by a metal strip 32 which was spot-welded thereto as indicated at 33. A small sectoral piece 34 was then soldered into the cutout 31 to complete the U-shaped frame half.

The two halves of each frame, such as the members 15 and 16, were then interconnected by soldering, as indicated at 35, with the aid of connecting strips such as the one shown at 36 in Fig. 5 which functioned, similarly to strip 32, to bridge the junction between these frame members. Parts of the lower edges 28 of the upper frame members 15, 16 and parts of the upper edges 30 of the lower frame members 17, 18 were cut away beyond the clearances 31, as illustrated for the edge 28' in Fig. 2, to accommodate the posts 11-14 which were then soldered or spot-welded to these members to complete the metallic frame of the tank 10. Finally, the sealing compound 19 was inserted into the various frame pockets and the bottom plate 20 along with side panes 21-24 were pressed against this compound which was then allowed to harden.

[Figure 207, *Refrigerated Display Tank, Number 2594474*] A refrigerated display tank patent for ma-

rine fish was assigned to Lewis J. McGrath of New-tonville, Maine (Figure 207-2594474) in 1952. This invention related to refrigerated display tanks and more particularly to an open top tank having a trans-pareent portion for displaying live aquatic creatures and maintaining them alive and in a clean and healthy condition. It provided an improved refrigerated display tank for live aquatic creatures that con-tained a large volume of water in proportion to the quantity of creatures displayed so that the same liq-uid could be used for an extended period of time and would not be subject to rapid temperature variations. It refrigerates the water and maintained the same at a predetermined low temperature and constantly circu-lated the water through the display space in the tank. The device constantly filtered and cleaned the water, using a coarse filter to remove the coarser dirt and debris and one or more fine filters to remove fine dirt and impurities, such as algae and bacteria. This pro-vided two independent water circulating means only one of which was connected with the fine filter or filters so that circulation of water could be main-tained even if such fine filters should become clogged. This also provided heat insulation around the entire body of liquid except the top surface to maintain the liquid at a substantially constant tem-perature and reduce the power requirements of the refrigerating equipment which constantly added air

to the liquid during the circula-tion. It included a heat insulat-ed transparent side panel in-crease the display effectiveness of the device and could also be provided with illuminating and reflective means for the same purpose.

Figure 1 is a perspective view of a display tank illustrative of the invention; Figure 2 is a cross sectional view on an enlarged scale on the line 2 - 2 of Figure 1; Figure 3 is a trans-verse cross sectional view on the line 3 - 3 of Figure 2; Figure 4 is a traverse cross sectional view on an enlarged

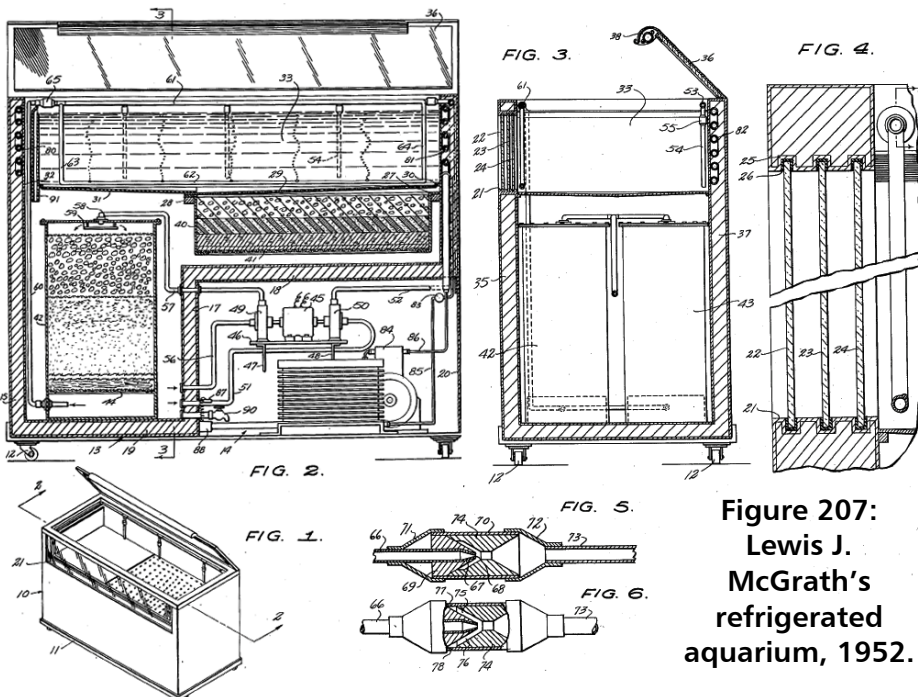

**Figure 207:
Lewis J.
McGrath's
refrigerated
aquarium, 1952.**

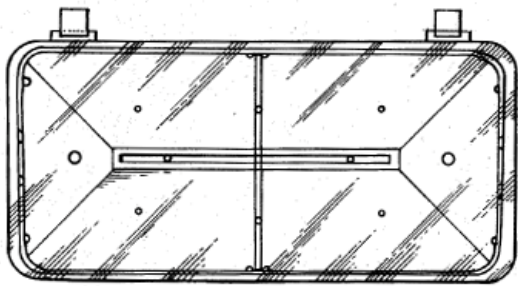

FIG. 1.

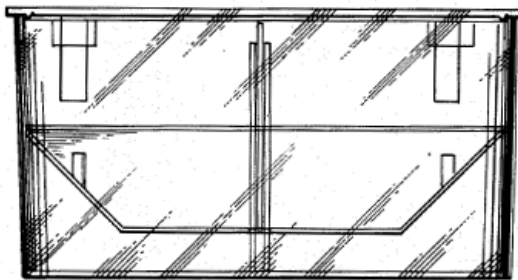

FIG. 2.

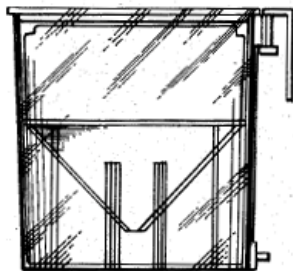

FIG. 3.

Figure 208: Harding W. Willinger and Herbert N. Nestler's breeding trap, 1954.

scale of a fragmentary portion of the device particularly illustrating the construction of a transparent panel provided in the device; Figure 5 is a longitudinal cross sectional view of a fragmentary portion of the device taken on the line 5 - 5 of Figure 4 and Figure 6 is a cross sectional view of the device illustrated in Figure 5 but is taken on a plane substantially perpendicular to the section plane of Figure 5.

The inventor's description of the invention was long and detailed but the figures 1, 2 and 3 give a good idea of what the invention was all about.

[Figure 208, *Aquarium Breeding Trap*, Number D171472] That well-known inventor of aquarium equipment and co-owner of Metaframe, Harding W. Willinger, along with his co-inventor Herbert N. Nestler, both of New York City, patented a breeding trap in 1954 that was a bit more modern in appear-

ance than prior breeding traps. As this was a design patent, the drawing tells all.

Figure 1 is a top plan of the aquarium breeding trap, showing the new design; Figure 2 is a front elevational view and Figure 3 is a side elevational view.

[Figure 209, *Shipping Container for Amphibious and Aquatic Animals*, Number 2476704] Three patents for transporting fish were issued during this decade. The first one was awarded to Jay E. Cook of Baltimore, Maryland (Figure 209-2476704) in 1949. This design (two configurations were shown: a cylinder and a box shape) differed considerably from previous can designs in that the water level would always be below the air inlet even if the container was tipped. Water, therefore, never could escape from the container and damage nearby packages.

Figure 1 is a top plan view or a front view, that is, a view of the side that contains the normally closed inlet and outlet opening of one form of the invention; Figure 2 is a view of the device shown in Fig. 1, the upper half being in section; Fig. 3 is a view of the

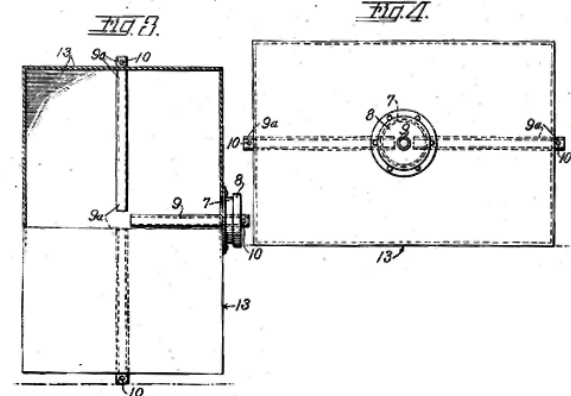
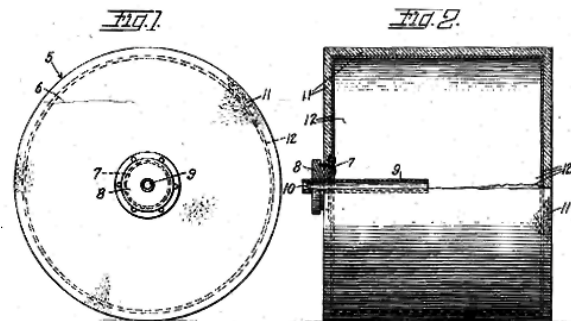

Figure 209: Jay E. Cook's shipping can, 1949.

modified form of the invention, the upper half being in section and Fig. 4 is a view of the device shown in Fig. 3 but turned with a front or inlet side toward the observer.

In Figures 1 and 2, the container **5** was cylindrical, and has a front or normally upper side **6** that has a central opening **7** fitted with a substantially water-tight closure **8** that was screwed into the opening **7** and adapted to be quickly and easily unscrewed and removed so animals could be passed through. The closure **8** was centrally apertured and an impervious-walled straight tube **9** had its outer end-portion extending through and secured to the material around this opening in water-tight relation by any appropriate means, as by relative expansion, welding, etc.

The center of the tube **9** was coaxial with the axial center of the container. When any portion of its convex surface was at the bottom, when it was slightly less than one-half full of water and other material, none of the water could then flow out and air could enter freely. If the container was then turned with the part **8** either at the upper or lower portion, the water-level would be below the inner end of the tube **9** so the water could not flow out but air could flow in through tube **9**; this was because the open inner end of the tube **9** terminated between and in a straight line with the center of the container and the center of the wall to which the tube **9** was secured. The outer end of the tube **9** was extended far enough beyond the closure **8** to permit an air hole or air holes **10** to be provided therein, so air would be supplied there through even if the outer end of the tube **9** was closed, as by being stood on a floor or being covered by anything which was placed thereon. The hole **10** permitted a tie (not shown) to be passed through for securing a tag bearing instructions, etc., for the care of the animals in the container.

The heat insulation **11** over the walls of the metal container **12** prevented the animals in the container from being subjected to sudden changes in temperature. No heat insulation was shown in Figs. 3 and 4, though it was applicable to Figs. 1 and 2, but insulation was not necessary where there was but slight change or slow changes in temperatures.

In the modified form of Figs. 3 and 4, the six-sided

container **13** could have all six of its sides provided with tubes **9** and **9a**, the tube **9** being secured to the closure **8** as in Figs. 1 and 2 with the tubes **9c** being secured in opposite walls of the container and at right angles to the tube **9**. All three of these tubes had their inner ends near the center of the container but spaced from the center-point in space. This arrangement not only provided several air inlets, but also provided a solid support on which a number of amphibious animals could perch or rest their heads while breathing air from above the water which has its level at or near the lower side of the tube when the cage was either in the position shown in Fig. 4 or in the inverted position; and in whatever position this form of invention was placed, the animals had at least two of the tubes to which they could cling.

[Figure 210, *Medium for the transportation and Storage of Live Fish, Number 2783736*] Another metal can patent was awarded in 1957 to George N. Washburn of Stoutland, Missouri. In addition to the usual container that supplied oxygen to the can, the invention also specified the use of activated carbon to remove impurities, an antibiotic compound, and, "Permutit," a synthetic resinous compound (a zeolite) that assisted in ammonia removal.

Figure 1 is a side elevation of a shipping or storing container partially sectioned and shown in association with an apparatus for supplying oxygen; Fig. 2 is a bottom plan view of the closure member for the container of Fig. 1; Fig. 3 is a partially sectioned side elevation view showing a modified form of sealed vessel and the means for supplying it with oxygen; Fig. 4 is a bottom plan view of the closure element of the vessel of Fig. 3 and Fig. 5 is a partially sectioned side elevation of a container similar to that of Fig. 1, but having different means for supplying oxygen.

First in the process, definite quantities of activated carbon were added to the transporting water. Such carbon had an affinity for many organic compounds frequently encountered in bacterial fish fecal breakdown, namely ammonia, amino acids and sulphates. The activated carbon was specific for the adsorption of certain organic compounds. An additional reagent

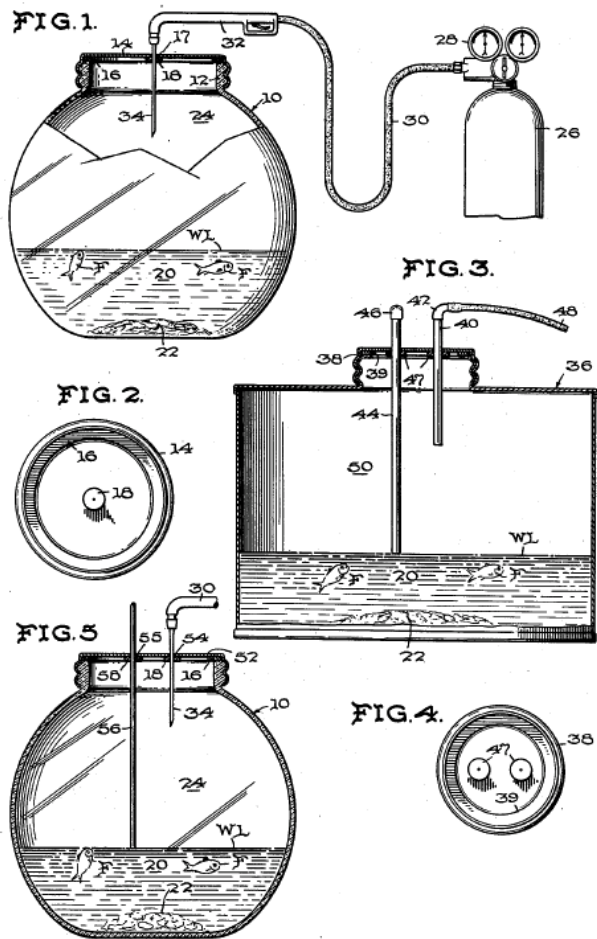

Figure 210: George N. Washburn's oxygen-fed shipping can with antibiotics and zeolite added, 1957.

mentioned above known by the proprietary name "Permutit" was added to assist in further ammonia removal. (Permutit is an artificial zeolite and a relatively small but predetermined amount was used.) It was useful for its sulphate affinity. Further purification of the transporting water was attained by the addition of small amounts of calcium carbonate which served the purpose of reducing the free carbon-dioxide which is harmful to fish life in excess quantities. To counteract the effect of the total mineral hardness, the calcium carbonate and the calcium bicarbonate formed were reduced by the addition of a small quantity of magnesium sulphate.

One other important factor that was found to materially improve the method was the introduction of a non-harmful chemical agent which was capable of

retarding the metabolic rate of the live fishes being transported. Urethane, when present in predetermined small quantities, safely slowed down the respiration rate by one-half over normal pulsations, and it was discovered that in this manner the fish required only about one-half the oxygen formerly used without this metabolic agent. The addition of small amounts of the antibiotic streptomycin sulphate to fish storage water containing the activated carbon, the calcium carbonate, the magnesium sulphate, oxygen and the urethane produced a very marked improvement in the well-being and the storage of fish.

[Figure 211, *Disposable Paperboard Shipping Aquarium, Number 2763239*] The patent awarded to Warren C. Rendall of San Francisco in 1956 (Figure 211-2763239) was a variation on the waxed, folded Chinese food take-out box we all know so well (and which also resembled the paper containers used in the early days when fish were sold). This design was of a far sturdier construction, however, and meant to replace the traditional metal cans commonly used at the time for larger shipments of fish.

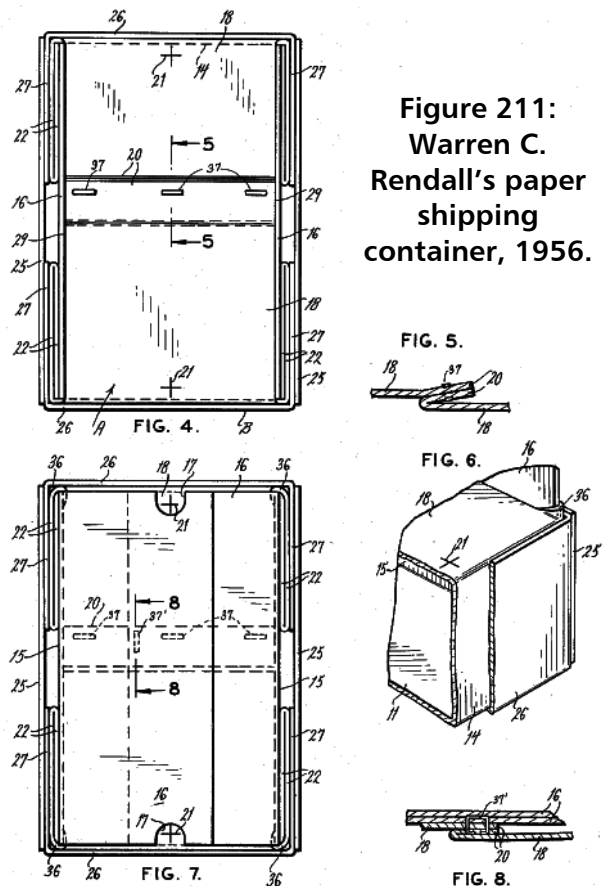

Figure 211: Warren C. Rendall's paper shipping container, 1956.

Figure 1 is a plan view of a blank of a waterproof insert employing a preferred form of this invention; Fig. 2 is a top plan view of an erected container shown with a water-proof insert, employing a preferred form of this invention in position; Fig. 3 is a side elevation of the container and insert shown in Fig. 2 taken through section 3 - 3; Fig. 4 is a top plan view of the container and insert illustrated in Figs. 2 and 3 with the end flaps of the insert in closed position; Fig. 5 is a fragmentary view through section 5 - 5 of Fig. 4; Fig. 6 is a fragmentary perspective view of the corner of a container and insert with the end cover flaps folded inwardly into closed position; Fig. 7 is a vertical, top plan view of the container and insert illustrated in Figs. 2, 3 and 4 with the side and end cover flaps positioned in closed position; Fig. 8 is a fragmentary, sectional view taken through section 8 - 8 of Fig. 7; Fig. 9 is a perspective view of a container employing an embodiment of this invention, illustrated with the cover member in position and Fig. 10 is a view of the complete container taken through section 10 - 10 of Fig. 9. An aerating device is shown inserted in position.

[Figure 212, *Reflector for Fish Tanks, Number D176905*] Three aquarium hood designs were patented during this period. The first two were design patents created by Julius C. Bruno of Newark, New Jersey in 1956, the first one resembling the roof of a house. Fig. 1 is a top perspective view of the reflector for fish tanks embodying the design; Fig. 2 is a

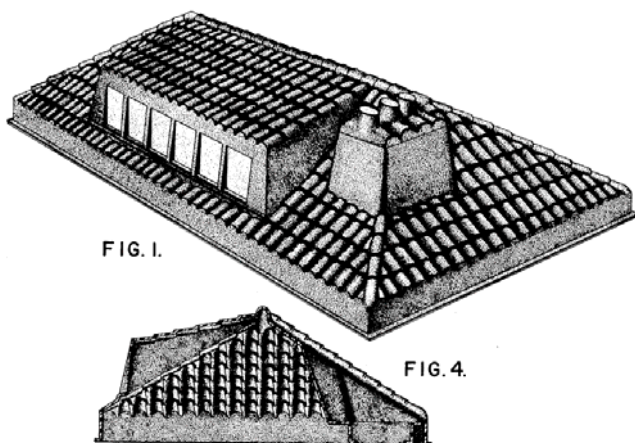

Figure 212: Julius C. Bruno's first hood design, 1956.

top plan view; Fig. 3 is a front elevational view and Fig. 4 is a vertical sectional view taken on the line 4 - 4 of Fig. 2 and looking in the direction of the arrows.

[Figure 213, *Hood Reflector for Fish Tanks, Number D176906*] The second was a very rounded and modern-looking design. Figure 1 is a top perspective view of the hood reflector for fish tanks embodying the design; Fig. 2 is a top plan view and Fig. 3 is a vertical sectional view taken on line 3 - 3 of Fig. 2 and looking in the direction of the arrows.

[Figure 214, *Aquarium Utility Housing, Number 2776642*] The third patent, issued to Joseph M. Sepersky in 1957 showed an aquarium hood that concealed the heating, lighting, and aeration equipment. This was the forerunner of the "Eclipse" type of hood sold today that added filtration to the equipment under the hood.

Figure 1 is a perspective view of an aquarium hood embodying the features of the invention shown in operative use upon an aquarium; Fig. 2 is a perspective view of the hood, shown alone, with the cover portion thereof in a raised position; Fig. 3 is a perspective view of the plastic insert, shown alone, for supporting the pump; Fig. 4 is an enlarged vertical

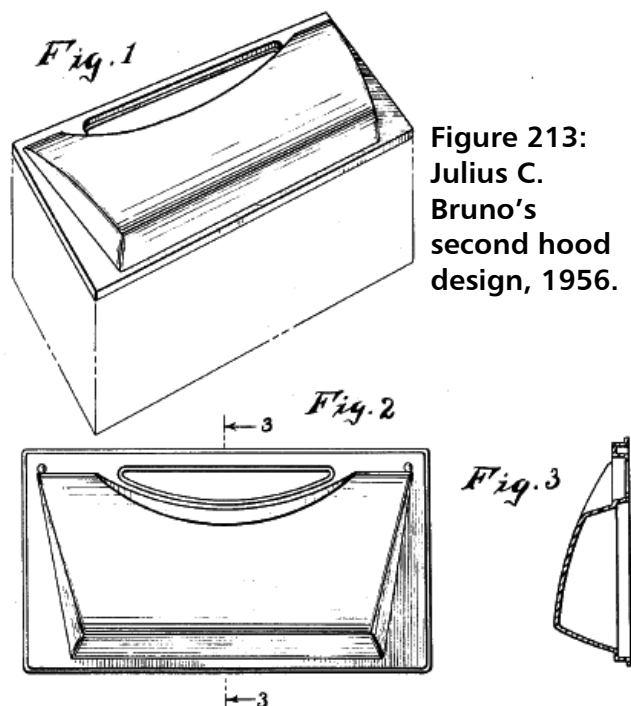

Figure 213: Julius C. Bruno's second hood design, 1956.

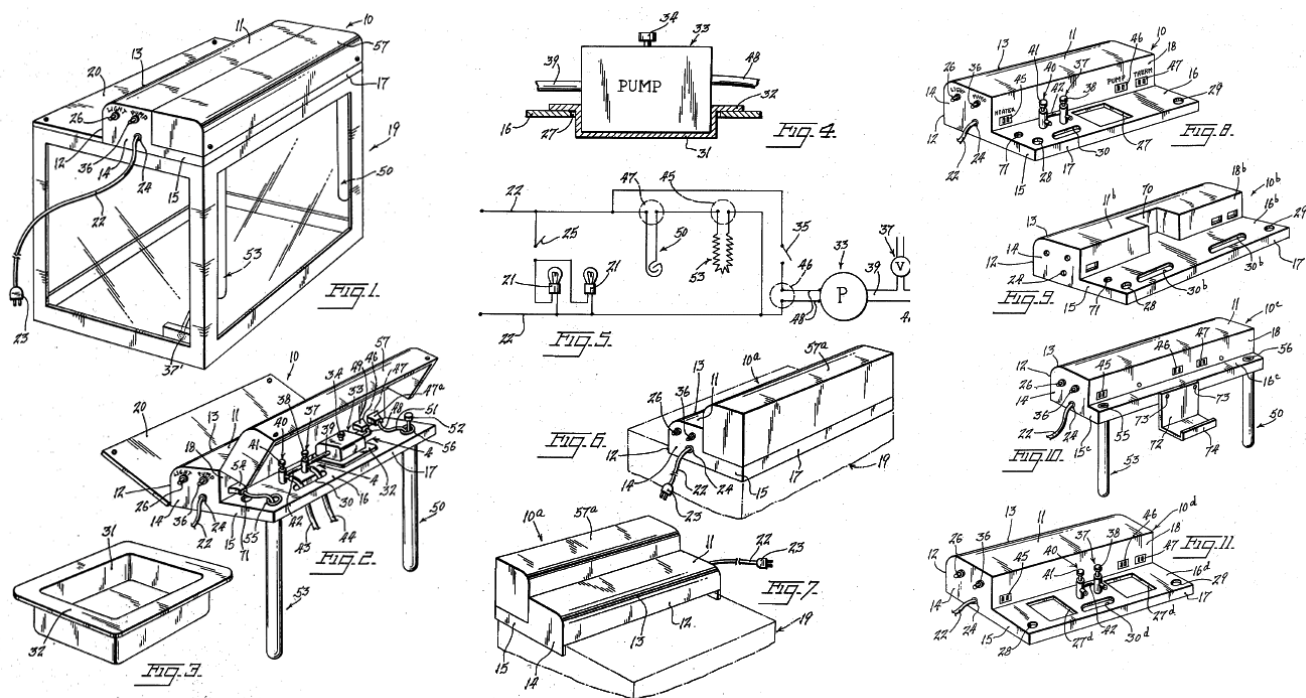

Figure 214: Joseph M. Sepersky's hood design that concealed lighting and aeration equipment, 1957.

sectional view taken along the line 4 - 4 of Fig. 2; Fig. 5 is a circuit diagram illustrating the manner in which the various units are connected electrically; Fig. 6 is a rear perspective view of a modified form of the invention; Fig. 7 is a front perspective view; Fig. 8 is a perspective view, similar to Fig. 2 and showing the first form of the invention, but with the hingeably mounted cover removed; Fig. 9 is a perspective view of a modified design; Fig. 10 is a perspective view of a still further modified form of the invention; Fig. 11 is a view similar to Fig. 8 but showing a still further modified form of the invention.

Referring to the figures, 10 designated a bowl that was provided with a suitable supporting base 11. The bowl was provided with a handle 12 in the form of a conduit which communicated with the bowl at diametrically opposed zones as indicated at 13. The

[Figure 215, *Aquarium*, Number 2512678] Designs for aquariums abounded in this decade, including two by Earl A. Rice of Meresburg, Pennsylvania in 1950 that consisted of a fish globe with a hollow handle the fish could swim through. This was the first one. Figure 1 is a vertical sectional view of the aquarium, the section being in the plane of the axis of the handle; Fig. 2 is an elevational view as observed from the right or left of Figs. 1 and 3 and Fig. 3 is a top plan view.

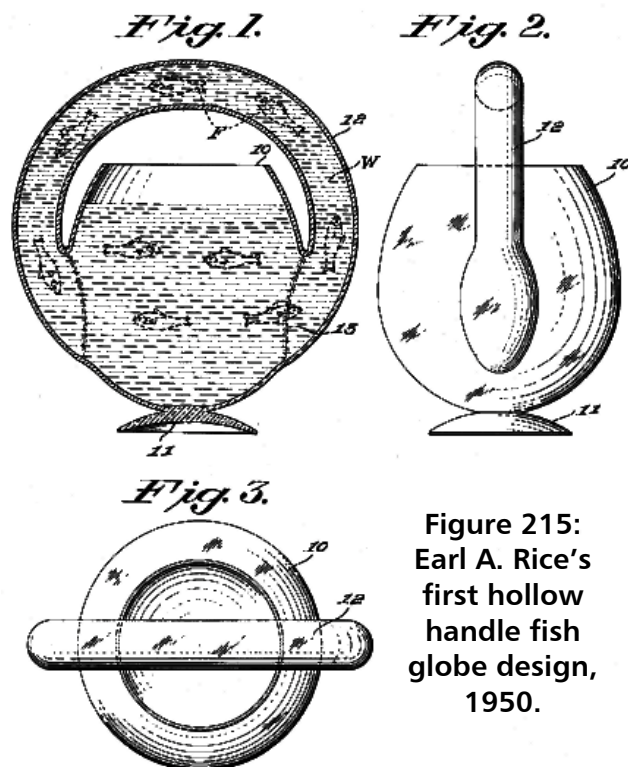

Figure 215: Earl A. Rice's first hollow handle fish globe design, 1950.

bowl **10**, base **11** and handle **12** were of unitary construction and were formed of glass as indicated, or of other suitable transparent material.

As was indicated in Fig. 1, the handle was filled with water as was also the bowl to a level between the top thereof and the zones of communication between the handle and bowl. The bowl and handle could thus be filled with water upon submerging both the bowl and handle in a body of water with the result that air would be forced out of the handle and displaced by water.

After the handle and bowl were thus filled with water, a small volume of water could be removed by any suitable means from the top of the bowl whereby the bowl and handle would be filled substantially as indicated in Fig. 1.

With this improved construction, fish **F** would have a range of movement through the bowl **10** as well as through the conduit or handle **12**, as is indicated in Fig. 1. With this increased range of movement,

which provided a circuitous course, the fish would swim with greater speed and more action, which together with the increased area or visibility of the fish as afforded by both the bowl and handle, the amusement provided by the aquarium would be substantially greater than that provided by aquariums of this general character heretofore in use. It was to be particularly noted that the handle **12** was endowed with two functions. First, it provided for convenient movement of the aquarium and second, it provided a substantially long arcuate passageway for the fish from one side of the bowl to the other side.

[**Figure 216, Fish Bowl, Number D160125**] This was the second one, a Design patent. Figure 1 is a front elevational view of a fish bowl showing the design; Fig. 2 is a plan view; Fig. 3 is an elevational view of the back of the fish bowl and Fig. 4 is an end elevational view.

[**Figure 217, Fish Bowl and Hollow Handle Assembly, Number 2646021**] The third was in 1953. The handles were filled in these three designs by submersing the whole device in water. Figure 1 in the left hand portion is a plan view of an aquarium exhibiting the invention while the right hand portion is a sectional view taken on the line **1 - 1** of Fig. 2; Fig. 2 in the left hand portion is a side elevational view and the right hand portion is a section taken on the line **2 - 2** of Fig. 1 and Fig. 3 is a side elevational view of one of the clip elements for retaining the tubular handle in the sockets of the bowl.

Referring to the figures, there was shown at **10** a bowl that could be formed of transparent material such as glass and formed one unit of the aquarium. A relatively large flat base **11** was provided at the bottom of the bowl so that the aquarium would stand upright on any generally horizontal supporting surface. The bowl was substantially circular in its lowermost portion and provided with a concave outer surface **12** and a convex inner wall surface. An open mouth **14** was provided in the top of the bowl **10** and the mouth was for the purpose of filling the bowl with water and was of such large cross sectional area as to permit atmospheric pressure to operate on the surface of the water that **1s** maintained at approxi-

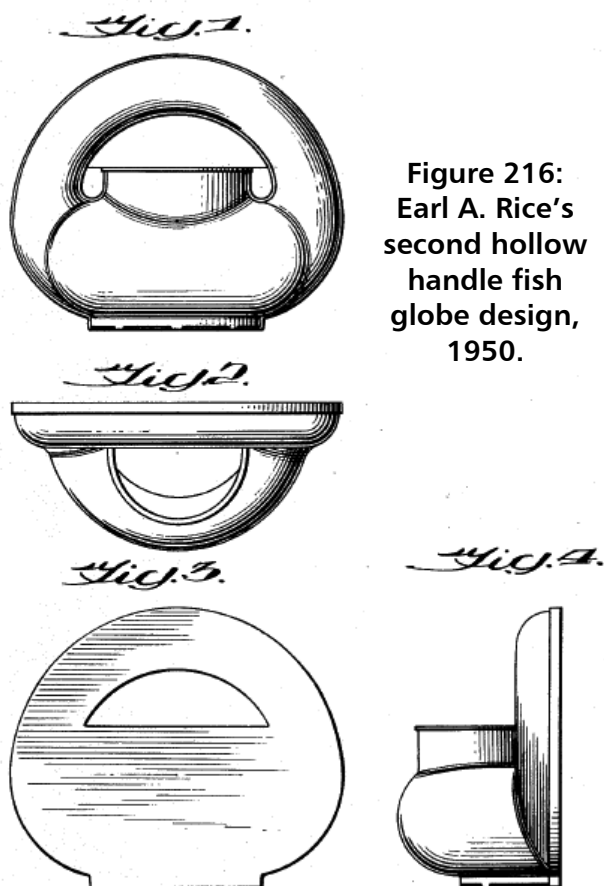

Figure 216:
Earl A. Rice's
second hollow
handle fish
globe design,
1950.

mately the level indicated at 16 in Fig. 2. A vertically arranged web or rib 17 was formed integral with the bowl structure and surrounded the opening in the top of this bowl. The web 17 was of elliptical formation as shown in Fig. 1. A flange 18 could be provided around the perimeter of the web 17 to improve the ornamental appearance of the bowl and to add strength to the upper portion of the bowl structure.

Relatively large and substantially horizontal portions 19 and 21 were provided on the upper wall surface of the bowl 10 at opposite sides of the elliptical shaped opening 14. These areas 19 and 21 provided space for accommodating a vertical opening 23 in the bowl for communication with the interior of a tubular handle 31. The web 17 was arcuate shaped and adjacent to the opening 23 to form a socket 24 that was integral with the web 17, as in Fig. 1. The socket 24 was of such circumferential extent as to embrace a major portion of a leg or the handle 31. A similar socket 26 was provided at the opposite side of the bowl and the lower open end 27 was in communication with the interior of the bowl 10 below the water level 16. The socket 26 was formed integral with the rib 17 and embraced a major portion of another leg of the handle.

The handle 31 was of a hollow tubular formation and formed of transparent material such as glass. The upper portion 32 of the handle was of hemi-circular shape and the depending legs 33 and 34 were integral with the arcuate portion. The handle was accordingly of inverted U-shape and the depending leg portions 33 and 34 were substantially straight and parallel with respect to each other in the portions below the tops of the sockets 24 and 28. The outside diameter of the handle 31 and particularly the depending legs 33 and 34 were of such dimensions as to fit snugly within the sockets 24 and 26. The lower end of the leg 33 were preferably angular or arcuate shaped as indicated at 36 so as to conform in general to

the contour of an adjacent portion of the wall of the bowl 10. The lower end of the leg 34 was similarly shaped as indicated at 37.

The bowl could be formed as one element of the aquarium and the handle could be formed as a separate element. The handle 31 could be readily mounted on the bowl by introducing the legs 33 and 34 in the respective sockets. The aquarium could be filled by introducing water through the open mouth 14. The water could be caused to rise and fill the hollow tubular handle 31 by withdrawing air from the interior of the handle in the zone indicated at 41. The bowl and handle could also be submerged and the aquarium arranged on one side with the handle 31 in a generally horizontal position. The water then flowed into one leg of the handle to push the air from

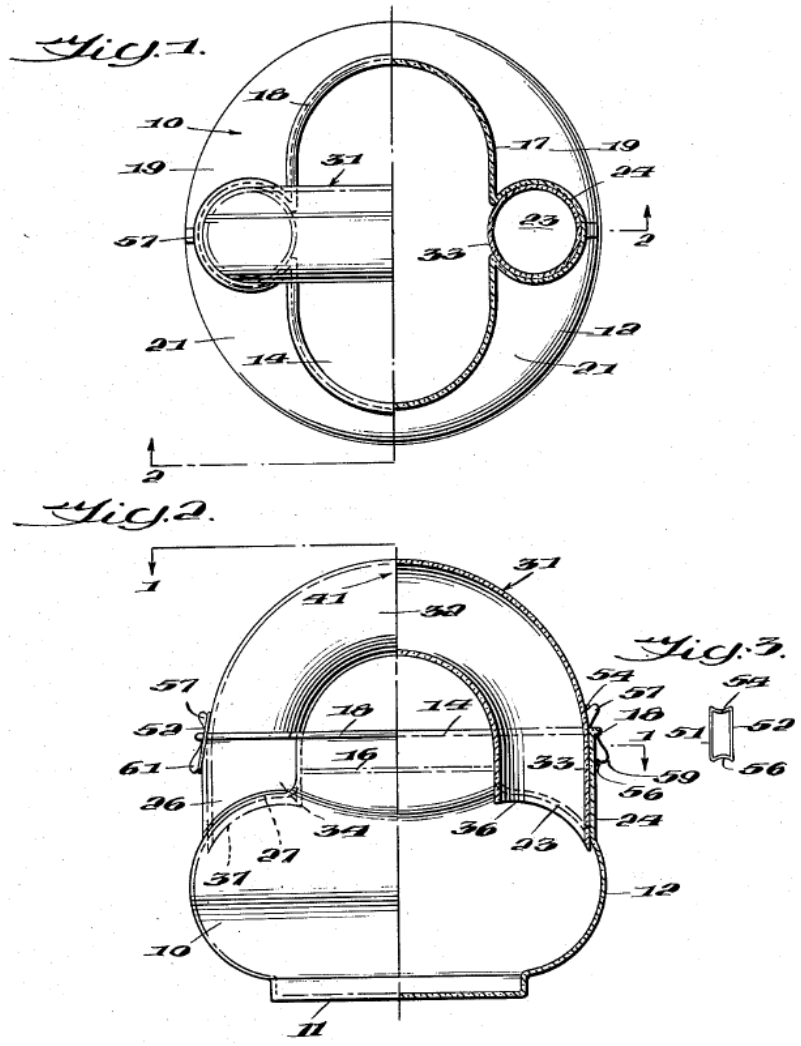

Figure 217: Earl A. Rice's third hollow handle fish globe design, 1953.

the other leg. The atmospheric pressure acting on the surface of the water through the open mouth 14 provided a force sufficient to support the water in the handle 31 and maintain the handle filled with water. The fish could swim in the bowl and swim through the hollow handle.

If it was desired the handle 31 could be more securely maintained in the sockets 24 and 26 by suitable means such as clips, one of which was shown in Fig. 3. Each clip or clasp could be formed of wire or the like having resilient characteristics. Each clip included side members 51 and 52 that were substantially parallel. The end portions 64 and 56 were bowed inwardly in the normal position as shown in Fig. 3. A lug 67 was formed integral with the handle 31 on the lower end of each leg as shown in Fig. 2. A lug 59 was provided on the socket 24 below the flange 18. A similar lug 61 was provided on the socket 26. The dip as shown in Fig. 3 was of such lengthwise dimensions that the end portions 54 and 55 could be snapped over the lugs 57 and 59 and similar end portions of another clip could be forced over the lugs 57 and 61 to thereby detachably secure the handle in

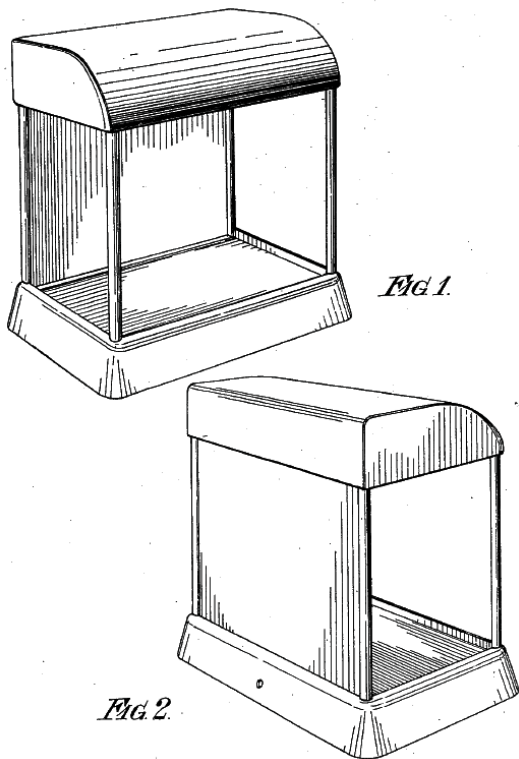

Figure 218: Roy E. Hollick-Smith's modern tank with hood, 1950.

position with the legs 33 and 34 in the sockets and prevent inadvertent detachment of the handle from the bowl.

[Figure 218, *Aquarium Frame*, Number D158074] A very modern tank design featuring rounded edges was patented in 1950 by Roy E. Hollick-Smith of London, England. Figure 1 is a front perspective view of the aquarium and Fig. 2 is a rear perspective view.

[Figure 219, *Combination Table, Aquarium and Plant Receptacle*, Number D159661] There were two table aquariums patented in this decade, the first by Lucille G. Newcome of Minneapolis, Minnesota in 1950 which was of a rectangular shape. Figure 1 is a top perspective view of the combination table, aquarium and plant receptacle; Fig. 2 is a side elevation and Fig. 3 is an end elevation.

[Figure 220, *Table*, Number D172706] The other one was by Hugh J. Davey and Robert O. Bextel of Frankfort, Indiana in 1954, an inverted dome shape. Figure 1 is a perspective view of a table, showing the design and Fig. 2 is a side elevation.

[Figure 221, *Console Bar with Aquarium*, Number D152456] There were also many novel aquarium designs, including one by Mac Buxbaum and

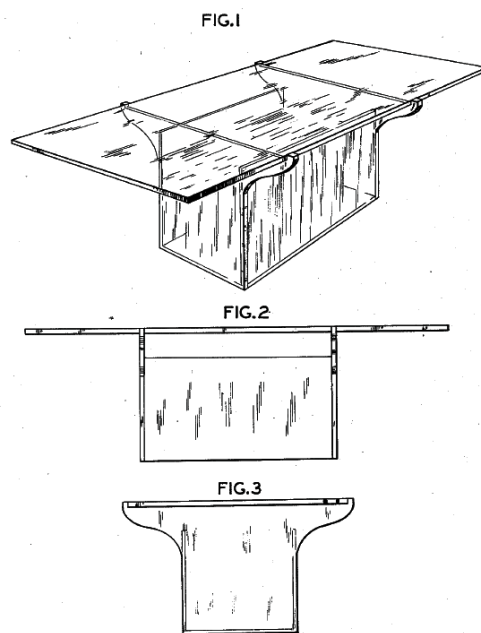

Figure 219: Lucille G. Newcome's aquarium, 1950.

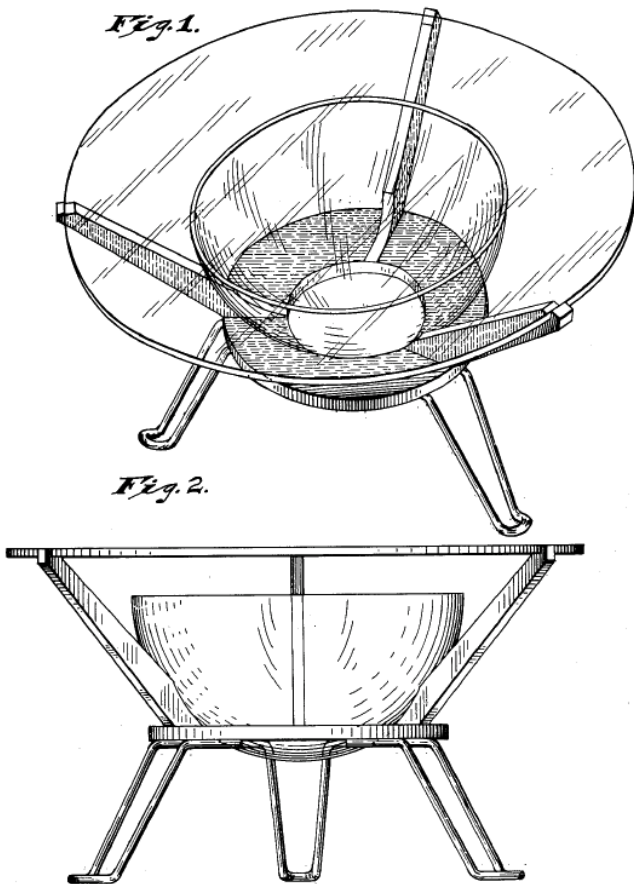

Figure 220: Hugh J. Davey and Robert O. Bextel's table aquarium, 1955.

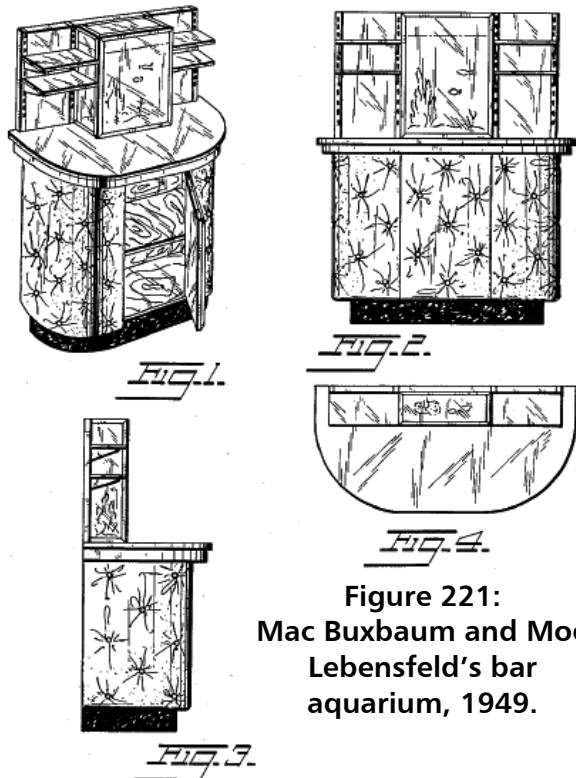

Figure 221: Mac Buxbaum and Moe Lebensfeld's bar aquarium, 1949.

Moe Lebensfeld of Flushing, New York in 1949 for a combination aquarium and bar that was very appealing, although the possible breakage due to the close proximity of the front of the aquarium to the usual glassware and bottle paraphernalia of a bar suggests that Mac and Moe had a few samples from their own bar as they were designing it. Figure 1 is a perspective view of the console bar with aquarium; Fig. 2 is a front elevational view; Fig. 3 is a side elevational view and Figure 4 is a top plan.

[Figure 222, *Combination Mantel, Aquarium and Fountain, Number 2503945*] Alice J. Grossniklaus of Wilmot, Ohio incorporated an aquarium in 1950 into a mantle over a fireplace, complete with a fountain for aeration and increasing the humidity during the winter. Grossniklaus allowed for the heat of the fireplace by insulating the bottom with a layer of rock wool. Figure 1 is a front elevation of a fireplace embodying the combination mantel and aquarium; Fig. 2 is a fragmentary plan elevational view thereof and Fig. 3 is an enlarged, vertical sectional view.

The fireplace shown in the figures included the rectangular hearth opening 5 that was formed by the side wall portions 6 and the top wall portion 7, there being preferably columns 8 positioned at the front of the side wall portions 6 supporting a mantel indicated generally at 9 in front of the top wall portion 7 and extending entirely across the same. The hearth opening of the fireplace was preferably lined with fire bricks 10 in a usual manner, above that were supported the usual bricks 11 forming the front wall of the

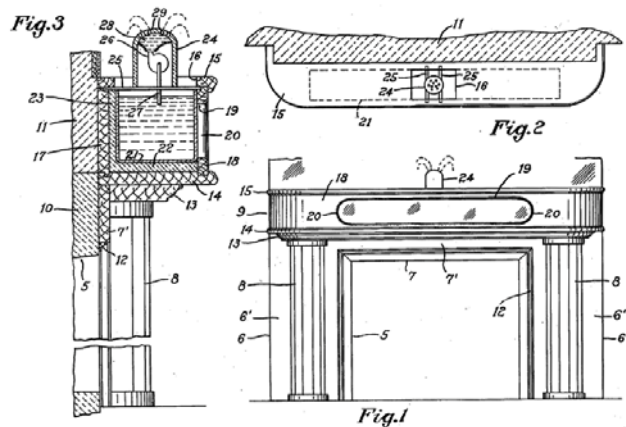

Figure 222: Alice J. Grossniklaus's fireplace mantle aquarium, 1950.

fireplace and extending upwardly to form the chimney therefor. The side walls **6** and top wall **7** could have a wood facing as indicated at **6'** and **7'** respectively, and the hearth opening **5** could be bordered with a molding **12** if desired. As shown the columns **8** could support a transverse ornamental wood piece **13** that overhung the top of the columns, and the piece **13** in turn supported a bottom mantel board **14** that overhung the piece **13** and extended the full width of the fireplace.

A top mantel board **15** of substantially the same length and width as the bottom board was spaced above the same and provided the top surface of the mantel, being provided with a central rectangular opening **16**. At the rear side of the top and bottom boards **14** and **15** a rear wall board **17** abutted the brick work **11** and extended between the top and bottom mantel boards to provide the rear wall of the mantel. At the front side of the mantel, a front wall board **18** extended between the top and bottom boards **14** and **15** to form the front wall of the mantel. The ends of top and bottom wall boards **14** and **15** and the front wall board **18** were curved on a radius, as indicated, to give an attractive appearance to the mantel, and in the central portion of the front wall board **18**, an elongated opening **19** having circular ends **20** was provided to give a recessed panel effect. An elongated tank **21** of rectangular cross section was positioned within the mantel **9** and could be constructed entirely of glass as shown, at least the front wall being of glass or other transparent material so that the contents of the tank or aquarium **21** were visible through the transparent front wall and the panel opening **19**.

In order to derive the benefit of the warmth of the fireplace in cold weather, without the possibility of overheating the aquarium so as to endanger the lives or condition of the tropical fish therein, a bottom wall **22** and a rear wall **23** of insulation material was provided, such as rock wool, between the bottom mantel board **14** and rear wall board **17** and the tank. Such insulation insured against overheating of the water in the aquarium when the fireplace became hot. However, the location of the aquarium in the mantel of the fireplace provided a moderately warm

location that was well off the floor of the room and away from windows or drafts, so that the temperature of the water in the aquarium was easily maintained substantially constant as required.

A fountain **24** for spraying the water of the aquarium into the air of the room above the same was supported over the opening **16** in the top mantel board **15** by means of metal strips **25** or the like. A suitable motor driven pump indicated diagrammatically at **26** was mounted within the fountain **24** and had an intake pipe **27** extending into the water in the aquarium, the discharge of the pump being directed into an upper fountain chamber **28** to spray water out of jets **29** in the upper wall of the fountain with such force and direction that the water fell back into the tank through the opening **16**. The water sprays issuing from the jets served to aerate the water of the fountain because the water immediately falls back into the tank, and such aeration was essential for maintaining the tropical fish in the aquarium in a healthy condition. At the same time, the water sprays in passing through the atmosphere of the room served to humidify the room; this was especially important in cold weather when the heated air of the room became too dry.

[**Figure 223, Aquarium, Number 2494937**] An interesting design was that created by Aaron Gandy of Seymour, Texas in 1950. There were two modifications of the horizontal cross-section – triangular and rectangular – but the main idea was the triangular vertical cross-section of both (Figure 223-2494937), the sloping walls producing a rainbow effect whenever sunlight fell onto the aquarium. The design also magnified the apparent number of fish in the aquarium.

Figure 1 is a top plan view; Figure 2 is a side elevational view with parts broken away and shown in section; Figure 3 is a top plan view of a modified construction; Figure 4 is an end elevational view of the modified construction with parts broken away and shown in section and Figure 5 is a fragmentary side elevational view.

Referring now to the figures in detail, the numeral **5** designated the open container constructed of glass or other transparent material and shaped in an inverted

pyramidal form having three sides **6**, **7** and **8**, the sloping side edges of each wall being at right angles or 90° with respect to each other and the walls being integrally molded or otherwise suitably united with each other. The sloping walls of the container merged at the bottom in a point **9** from which side edges or corners **10** extended upwardly and outwardly on the outer surface of the container at the adjacent junctions of the walls.

The container **5** was supported in an elevated position by means of a stand **11** that included trough-like members **12** in which the lower portions of the side edges or corners **10** were seated, the troughs **12** being constructed of metal or other suitable material having their lower ends welded or otherwise fixedly secured to each other and adjacent the lower ends of the trough legs **13** extended outwardly and downwardly. The upper edge of each of the walls **6**, **7** and **8** extended horizontally, as indicated at **14**, and the upper corners of each of the walls were cut at angles of approximately 135° , as indicated at **15**, to eliminate any sharp corners at the upper edge of the container.

In the form of the invention illustrated in Figures 3, 4 and 5, the container was designated generally at **16** and was likewise constructed of glass or other suitable transparent material and included a pair of triangularly-shaped end walls **17** and **18** and a pair of rectangular-shaped side walls **19** and **20**, the meeting edges of the walls being integrally molded or otherwise united with each other. The end walls **17** and **18** extended perpendicularly, while the side walls **19** and **20** sloped outwardly from the bottom of the container, the container thus being of substantially trough-like construction.

The container **16** was likewise supported in an elevated position on a base designated at **21** and that included a horizontal trough-shaped member **22** extending longitudinally under the lower edge of the container and in which the lower edge of the container was seated. At each end of the trough member **22** upwardly and outwardly inclined trough members

23 were welded or otherwise suitably connected at their lower ends and in which the corners of the container **16** were seated. Legs **24** were welded or otherwise fixedly connected to the trough-like supports **23** and extended downwardly and outwardly at each side. A brace **25** connected the lower portions of the legs **24**.

The upper corners of the container **16** at both the end walls **17** and **18** and at the side walls **19** and **20** were cut at angles of approximately 135° , as shown at **26**, to eliminate any sharp corners at the upper edge of the container. The containers **5** and **16** were adapted to serve as aquariums for holding water with fish swimming therein, and the sloping walls of the containers functioned as prisms so that when the rays of sunlight struck the sides of the containers, a multiple rainbow effect was produced and a multiple effect was produced of the fish swimming in the containers. The containers or bowls **5** and **16** could be readily removed from their supporting stands for cleaning when desired.

[Figure 224, *Fish Bowl Having Reflective Surfaces*, Number 2808024] Arthur R. Glidden of Seattle, Washington in 1957 also achieved this effect by incorporating a multiplicity of sides in the aquarium, some of which were coated with a reflective material (Figure 224-2808024). Glidden also provided a "fish jump," **12** in the diagram, consisting of a channel-like structure which extended from below the water

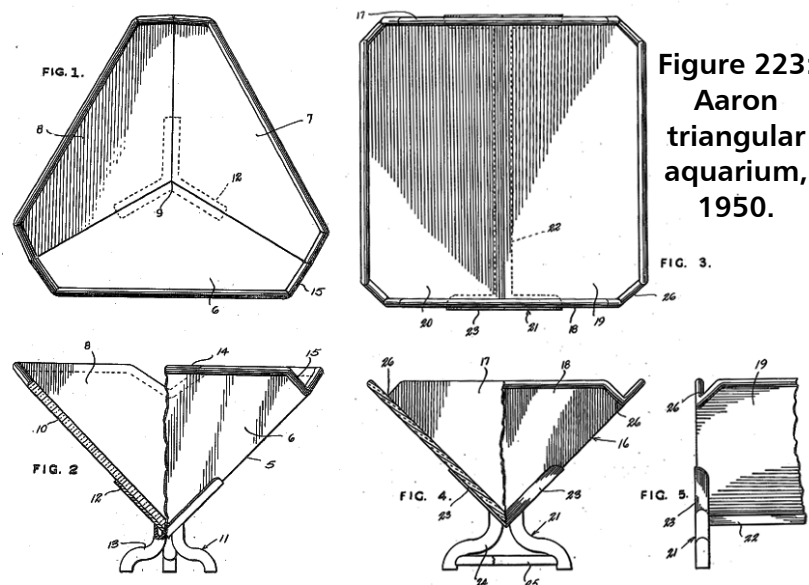

Figure 223:
Aaron
triangular
aquarium,
1950.

level to a diving edge elevated somewhat above such level from which the fish could leap into the water (Glidden could have saved himself the trouble just by putting some *Rivulus*, the all-time aquarium champion jumpers, in the tank!).

Figure 1 is a top plan view of a fish-bowl showing the fish jump and the reflective surfaces; Figure 2 is a vertical cross-sectional view taken on line 2 of Figure 1; Figure 3 is a vertical cross-sectional view taken on line 3 of Figure 2 and Figure 4 is a vertical cross-sectional view taken on line 4-4 of Figure 2.

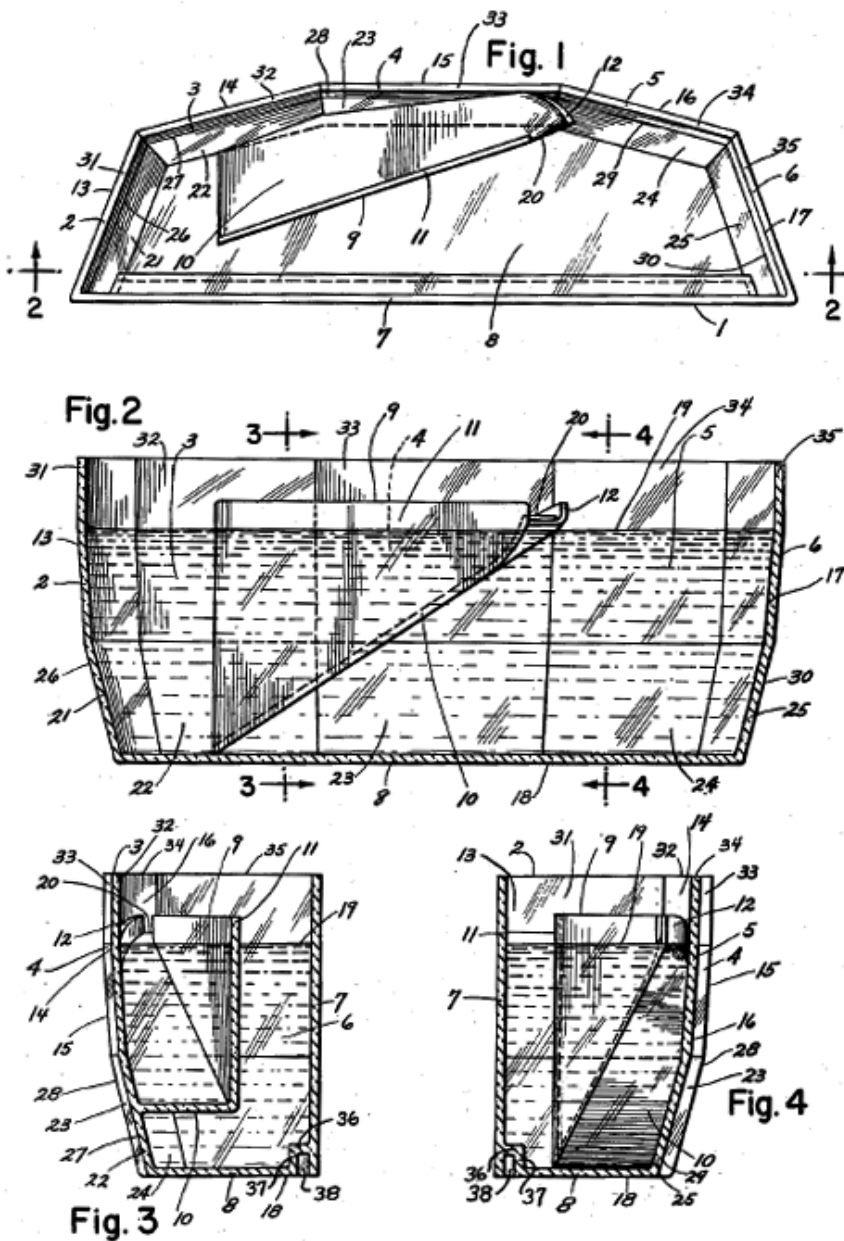

Figure 224: Arthur R. Glidden's multifaceted tank design, 1957.

Referring to the figures, the invention comprised an elongated fish-bowl having a multiplicity of facet-like sides and back walls various parts of which were coated with a reflective material and provided interiorly with a fish jump 9. The front wall 7 and the bottom wall 8 were not coated and through the former of these walls the fish could be seen swimming and leaping from the fish-jump in the interior of the bowl. Along the bottom and front of the bowl was a recess 38 formed by the lower part of the front wall 7, wall 36 protruding horizontally from the back side of the front wall toward the center of the bowl, and vertical wall 37 extending from bottom wall 8 toward the interior of the fish-bowl and uniting with 36. This recess 38 was of such a size that a decal with decorations could be inserted and secured in it. The bowl had a number of flat smooth facets 2, 3, 4, 5, 6, 21, 22, 23, 24, and 25 located below the level of the water 19, and also had facets 31, 32, 33, 34, and 35 lying above such level. Each of such below-level facets was provided upon its exterior surface with a coating of reflective material 13, 14, 15, 16, 17, 16, 27, 28, 29, 30, while the facets lying above such a level could or could not have a reflective material. The reflecting surface reflected into the interior of the bowl and could be silver or aluminum applied to the outer surface of the above named sides in much the same manner as they are applied to a mirror.

The fish jump 9 was a channel-like structure that extended from below the water level to a diving edge elevated somewhat above such level and from which the fish could leap into the water. The fish-jump had a channel floor 10 that extended from the lower part of the bowl to a little above the water level with its lower part wider than the upper part; the

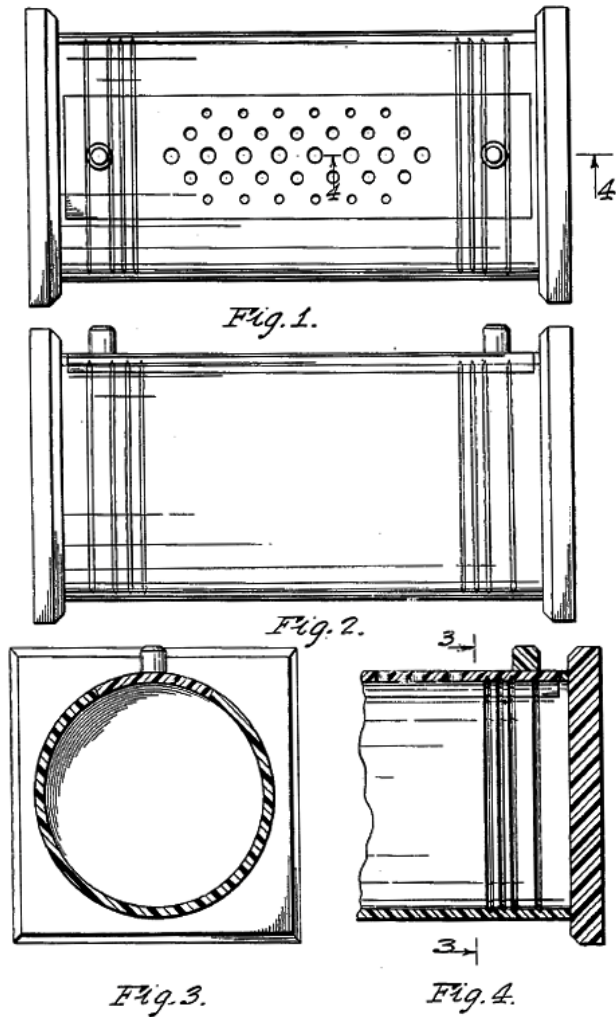

Figure 225: Francis J. McMorrow's Horizontal cylinder tank design, 1953

lower surface of the channel floor could be mirrored. Floor 10 had one edge integral with and extending more or less at right angles facets 22, 23, 4 and 33 with that part near the water level bending up at approximately a right angle to form side 12 that curved inwardly and terminated flush with the straight exterior face 11 of the support. Such face bent up at approximately a right angle to form a vertical triangular shaped side with its upper edge out of the water. This face was not a true triangle as it did not reach an apex near side 12 but at this part extended straight up permitting channel floor 10 to terminate in a diving lip 20. The fish swam into the channel-like structure, formed by floor 10, sides 11 and 12 and sides 22, 23, 4 and 33 of the bowl to the end of the support and leapt over diving lip 20 into the water. The fish jump

could be made of the same material as the fish bowl proper and fused to sides 22, 23, 4 and 33 of the fish bowl to make an integral unit.

[Figure 225, *Aquarium*, Number D168582] Two unusually-shaped aquarium designs were patented in 1953, one by Francis J. McMorrow of Stamford, Connecticut, a cylinder. Figure 1 is a top plan view of an aquarium embodying the design; Fig. 2 is a side elevational view; Fig. 3 is a transverse sectional view taken on lines 3 - 3 of Fig. 4 and Fig. 4 is a fragmentary longitudinal sectional view taken on line 4 - 4 of Fig. 1.

[Figure 226, *Annular Transparent Aquarium*, Number D169866] The other one was by Karl A. Rice of Mercersburg, Pennsylvania, a doughnut. Figure 1 is a front elevational view of the annular transparent aquarium showing the design; Fig. 2 is a side elevational view; Fig. 3 is a rear elevational view; Fig. 4 is a plan view; Fig. 5 is a perspective view of the annular transparent aquarium; Fig. 6 is a sectional view taken on the line 6 - 6 of Fig. 8; Fig. 7 is a sectional view taken on the line 7 - 7 of Fig. 6 and Fig. 8 is a vertical section taken on the line 8 - 8 of Fig. 6.

[Figure 227, *Aquarium or the Like*, Number D167243] A novelty aquarium was patented in 1952 by Bernard Yellin of Chicago, a round, flat aquarium containing a palm tree emerging from the center. Fig. 1 is a perspective view of an aquarium or

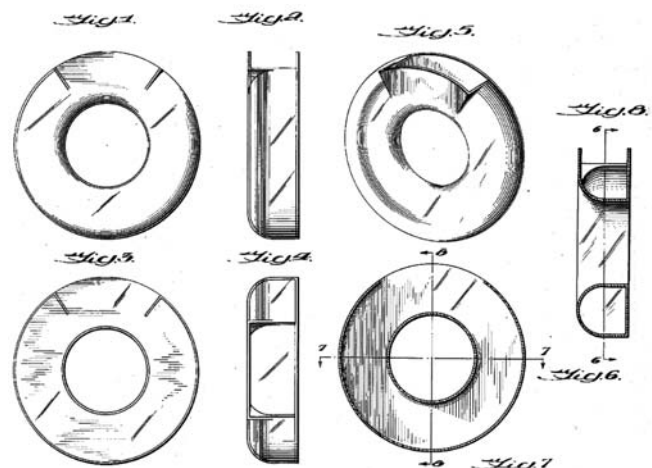

Figure 226: Karl A. Rice's doughnut tank design, 1954.

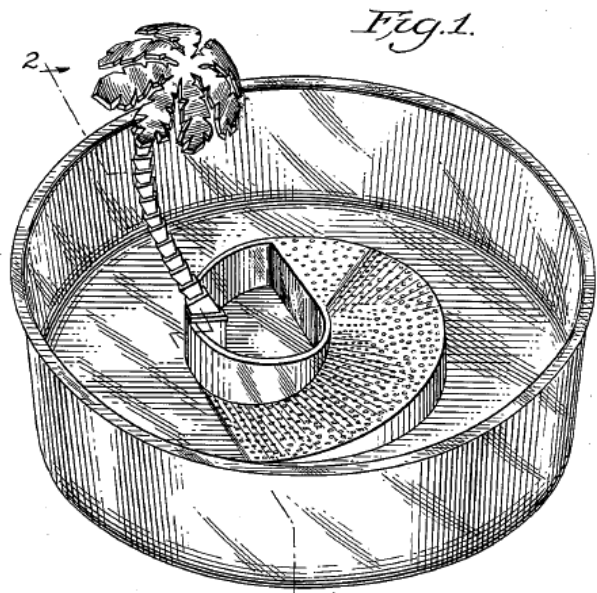

Fig. 1.

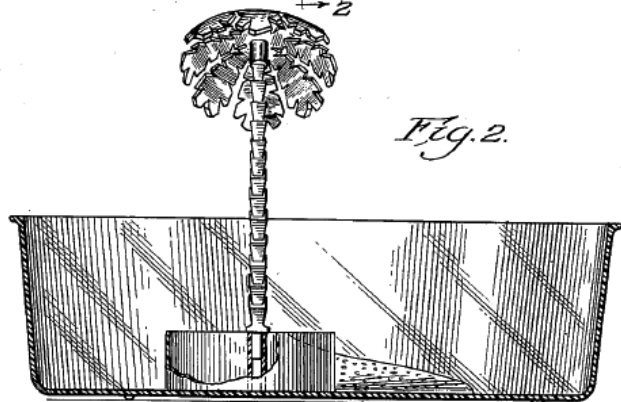

Fig. 2.

Figure 227: Bernard Yellin's palm tree tank design, 1952.

the like, showing the design and Fig. 2 is a view partly in cross section taken on lines 2 - 2 of Fig. 1.

[Figure 228, *Rubber Octopus*, Number 2844912] Another novelty aquarium was by John A. Sebesta of Long Island City, New York in 1958, an octopus. Sebesta's octopus was an aerator whose arms flailed about as air was pumped into it.

Figure 1 is a fragmentary perspective view of a fish tank or aquarium, with a toy octopus formed according to the invention positioned on the bottom; Fig. 2 is a sectional view through the aquarium showing the octopus in full lines at the bottom and in dotted lines after it has traveled upwardly to the upper limit of its movement; Fig. 3 is an enlarged sectional view

through the octopus; Fig. 4 is a detail sectional view still further enlarged through one of the tentacles and Fig. 5 is a sectional view on line 5 - 5 of Fig. 3 on the same scale as Fig. 4 through another one of the tentacles.

The octopus was illustrated in a conventional aquarium or fish tank, designated as 10, having a bottom 12 and side walls 14. A quantity of sand was deposited upon the bottom in the usual manner and supported upon the sand was a toy octopus 16 formed according to the invention. The article was formed of molded rubber, flexible plastic or the like, and included a generally globular head 18 merging at its lower end into a neck portion 19 which was reduced in diameter relative to the greatest diameter of the head. The head, as shown in Fig. 3, was hollow and was wholly open at its lower end. Formed on the outer surface of the head were protuberances 20, simulating the eyes of the octopus.

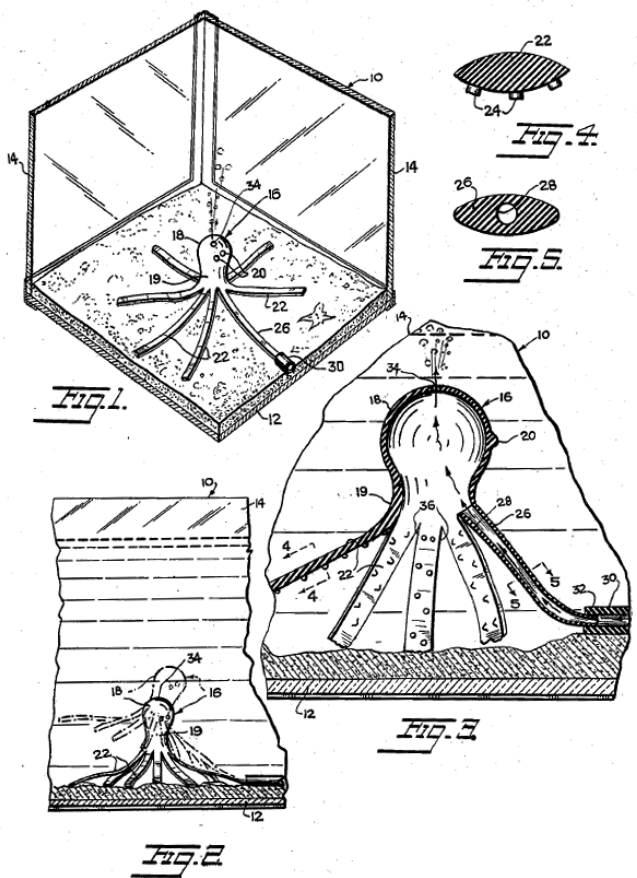

Figure 228: John A. Sebesta's flailing arm octopus Aerator, 1958.

Formed integrally with and depending from the neck portions were tentacles **22**. These were formed as elongated, highly flexible strips of rubber material, of flattened solid cross section as shown in Fig. **5**, and on the underside of the tentacles **22**, there were integrally formed protuberances **24**, simulating the suction cups of the tentacles of a live octopus. In addition to the flattened tentacles **22** of solid cross section, there was provided a tentacle **26**, which was of tubular formation from end to end, the tentacle **26** being formed open at its opposite ends. The tentacle **26** was of a shallowly elliptical cross section, having a longitudinally and centrally extending bore **28** providing a conduit for air pumped through the conventional outlet tube or hose **30** of an ordinary aquarium air pump, not shown. At its outer end, tentacle **26** had a cylindrical portion **32**, adapted to be frictionally engaged in the outlet end of the hose or tube **39** to connect the bore **28** in communication with that of the tube.

The tube could be partially or completely buried in the sand so as to substantially conceal it from one viewing the aquarium, and the weight of the tube and the fact that it could be so buried caused the tentacle **26** to be firmly anchored at its outer or inlet end. At its inner or discharge end the tentacle **26** opened into the lower end of the head **18** of the octopus. Therefore, when air was pumped through tube **30**, it would tend to fill the head **18**. In this connection, head **18** had at its upper end a centrally disposed, very small outlet port **34** for air. The size of the port was such that air directed into the head of the octopus while the octopus was in its lower, full line position of Fig. **2**, would initially be trapped, forming a pocket of air in the head **18**. In this connection, the octopus was ordinarily non-buoyant, and therefore, the pocket of trapped air tended to escape to the surface and in doing so it rendered the octopus buoyant, causing it to rise slowly toward the surface of tank **10**.

Since tentacle **26** was tethered to tube **30**, the octopus could travel only in a shallow, prescribed arc between its full and dotted line positions, pivoting, in effect, about the connection of tentacle **26** to tube **30**. Thus, the octopus, having traveled upwardly to its maximum extent, was halted due to its connection to

the tube **30**. The cessation of upward movement of the octopus helped the air gathered in head **18** to escape through the orifice or air outlet port **34**, it being noted that since the head was now tilted, some of the air could escape through the spaces **36** defined between adjacent tentacles of the toy. Once the air had escaped, the buoyancy of the octopus was lost. It therefore sank slowly to the bottom, traveling downwardly within the same arc.

The sequence was repeated continuously as long as air is supplied. Therefore the octopus was usable as the outlet for air that was ordinarily supplied from the discharge end of the air tube for the purpose of aerating the aquarium water. Since the octopus traveled within an arc, it had the effect of providing an arc-like shifting discharge nozzle or outlet head for the air tube, producing the desirable result of increasing the distribution of the air bubbles within the water. This was distinguished from the ordinary arrangement in which the outlet for the bubbles used for aeration pumps remained fixed at all times in a particular location of the tank, until such time it was positively moved.

The timing and the rapidity of the rising and falling movements of the octopus were adjustably controlled by using a regulating valve or clamp, not shown, in the air tube. In other words, if a rapid up-and-down movement of the octopus was desired, a greater quantity of air would be discharged through the tube. Slower movements of the octopus correspondingly were effected by a retardation of the air flow through the tube. Still another feature of the invention resulted in the use of the several radially extending tentacles **22**. These not only had the function of adding to the lifelike duplication of the figure of a real octopus, but also served as stabilizing wings or arms, which extending outwardly from the head, maintained the head in an upright condition and prevented its accidental inversion during its upward and downward movements.

[Figure **229**, *Aquatic Figure Toy, Number 2720724*] Another novelty aquarium was patented by Earl A. Rice in 1955 (he was a busy man in that dec-

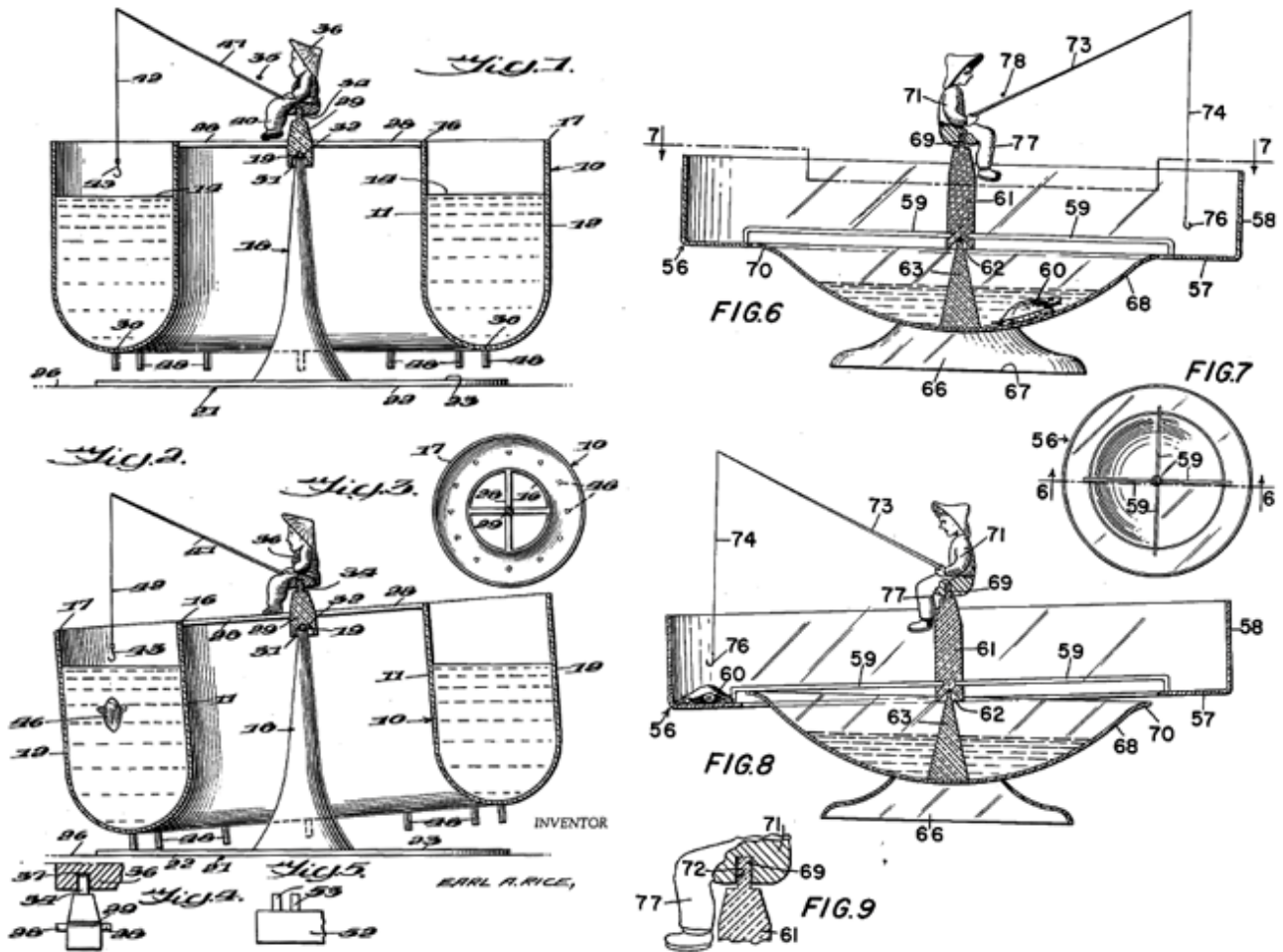

Figure 229: Earl A. Rice's pivoting aquarium, 1955.

ade!) that consisted of a round fish bowl balanced on a central pivot. It was fitted with a model of a fisherman holding a fishing pole and line (the variation shown was designed for a turtle tank). This is probably the silliest patent described in this book. The device was supposed to tilt in response to the weight of a fish, but had the aquarium ever been built it would have been discovered that achieving the perfect balance necessary for it to operate would be very difficult indeed. Inventions like these were apparently designed for those aquarists who also delighted in decorating their tanks with "burping clams" and miniature castles.

Figure 1 is an elevational view of an aquarium embodying the invention with the trough and other portions shown in section; Fig. 2 is a similar view showing the aquarium in a tilted position; Fig. 3 is a plan view on a reduced scale with the element representing a fisherman omitted; Fig. 4 is a side elevation of

the bearing member showing the character of the support for the fisherman; Fig. 5 is a fragmentary side elevation of a modification; Fig. 6 is a sectional view of another embodiment taken on the line 6 - 6 of Fig. 7; Fig. 7 is a sectional plan view on a reduced scale taken on the line 7 - 7 of Fig. 6; Fig. 8 is a view similar to Fig. 6 showing a tilted position of the annular member and Fig. 9 is a fragmentary sectional view illustrating the support of the fisherman element. The inventor's description is long and complex but the figures pretty much show how it all worked so his description is omitted here.

[Figure 230, *Ornamental Aquarium*, Number 2595085] A more meaningful and really imaginative design was one patented in 1952 by Fred Kuriyama of Waianae, Hawaii. In Kuriyama's designs (two modifications were described) the aquarium was attractively framed, with a plant box located underneath. The idea was to grow vines or other plants of

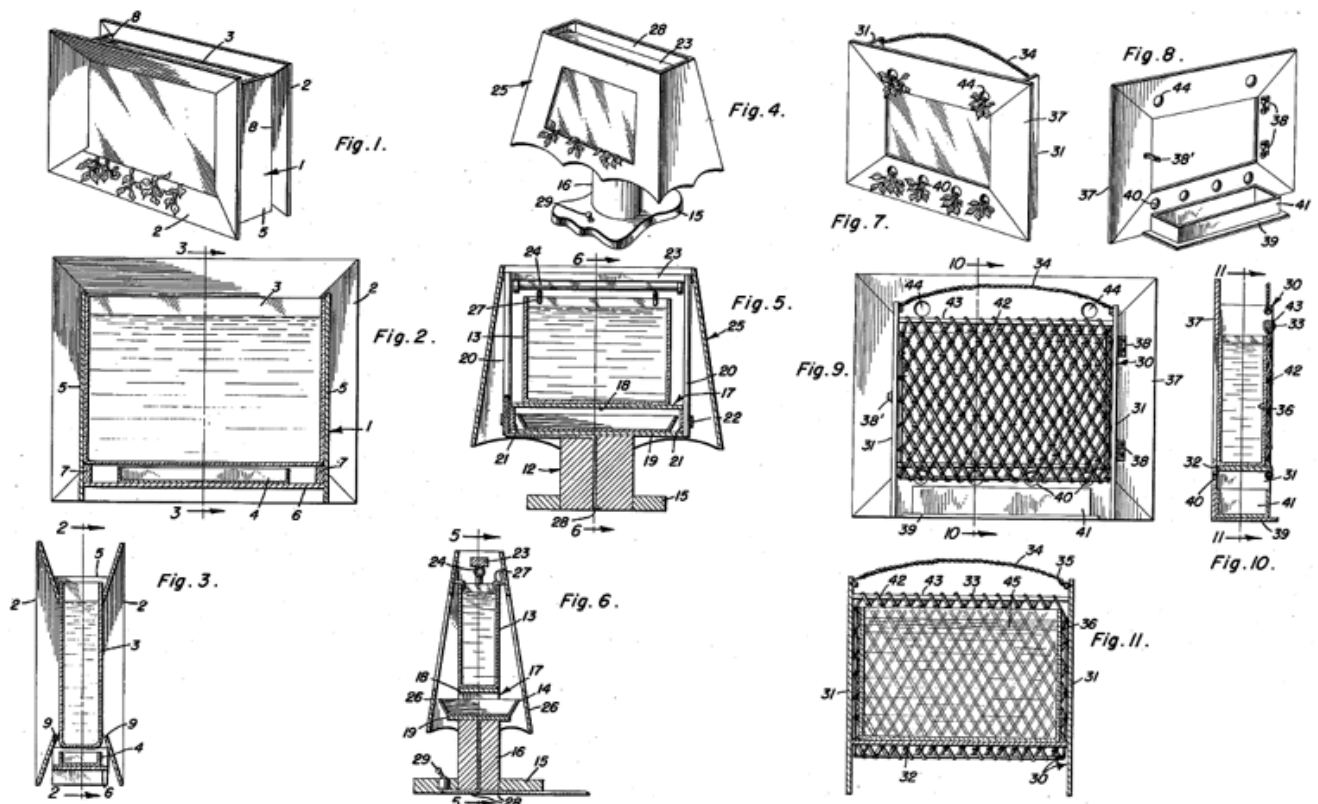

Figure 230: Fred Kuriyama's aquariums with concealed flower pots, 1952.

a similar creeping nature so that the leaves hung on the outside of the aquarium. The plant box was not seen since it was concealed within the framing. The only weakness of these designs was that the aquarium and its frame had to be lifted to gain access to the plant box. Thus, the tanks had to be small and were the reason why Kuriyama chose a very narrow design for his aquariums.

Figure 1 is a view in perspective of an aquarium in a preferred embodiment thereof; Figure 2 is a view in vertical longitudinal section, taken on the line 2 - 2 of Figure 3 and drawn to a larger scale; Figure 3 is a view in transverse section taken on the line 3 - 3 of Figure 2; Figure 4 is a view in perspective of a modified embodiment of the aquarium; Figure 5 is a view in vertical longitudinal section of the same taken on the line 5 - 5 of Figure 6 and drawn to a larger scale; Figure 6 is a view in transverse section taken on the line 6 - 6. of Figure 5; Figure 7 is a view in perspective of a second modified embodiment; Figure 8 is a view in perspective of the front frame and parts carried thereby; Figure 9 is a view in rear elevation

drawn to a larger scale; Figure 10 is a view in transverse section taken on the line 10 - 10 of Figure 9 and Figure 11 is a view in vertical longitudinal section taken on the line 11 - 11 of Figure 9.

Referring to Figures 1 to 3, the preferred embodiment of the improved aquarium comprised a substantially U-shaped support 1 for a pair of side frames 2, a water tank 3 and a plant box 4. The support 1 embodied a pair of upright elongated end panels 5 connected, in any suitable manner, adjacent the lower ends by a horizontal bottom panel 6 of the same width as the end panels 5. Cross cleats 7 on the top of the horizontal bottom panel 6, at the ends thereof, braced the support and served a further purpose to be explained. The panels 5 and 6 and the cleats 7 could be formed of any suitable light, strong material. The side frames 2 were each of open, rectangular, dished form, and were suitably fixed to the vertical side edges 8 of the end panels 5 to extend into the support 1 and flare outwardly. As best shown in Figure 3, the side frames 2 were level with the lower ends of the end panels 5 and completely hide the

support **1** at opposite sides. Also, as shown in Figure 3, the side frames **2** were spaced apart equidistantly upon opposite sides of the vertical longitudinal center of the support **1** and for a purpose to be described. The water tank **3** was of flat rectangular form, and any suitable transparent material, and was removably fitted between the side frames **2** and the end panels **5**, with bottom corners seated on the cross cleats **7** to space the tank above the bottom panel **6**.

The plant box **4** was of elongated rectangular form and removably seated on the bottom panel **6**. In order that the plant box **4** could be inserted between the side frames **2** onto the bottom panel **6**, the box was narrower than the space between the frames. As best shown in Figure 3, the plant box **4** was shallower than the space between the bottom of the water tank **3** and the bottom panels **6** and at the bottoms of the side frames **2**, the inner edges thereof were spaced outwardly of the sides of the water tank **3** for a purpose to be presently explained. The inner edges of the side frames **2** overlapped the vertical and horizontal corners of the water tank **3** so that the frames framed the tank and concealed the top, bottom and ends.

In using the aquarium, it was stood on a support with the lower ends of the end panels **5** and the bottom edges of the side frames **2** resting thereon. The water tank **3** was used in the usual manner. Plants were grown in the plant box **4** to project out of the spaces **9** between the sides of the water tank **3** and the inner bottom edges of the side frames **2**. As illustrated in Figure 1, such plants would hang downwardly out of the side frames **2** and form an ornamental growth along the bottom of the aquarium. The water tank **3** could be lifted out of the support **1** from between the side frames **2** for refilling and replacement, and the tank could be so removed, also the plant box **4** for cleaning out or any other purposes. In the modified embodiment of the aquarium shown in Figures 4, 5 and 6, the same has the form of a table lamp with a support **12** for a water tank **13** and a plant box **14**.

The support **12** comprised a base **15** having a pedestal **16** rising therefrom. An elongated, rectangular frame **17**, open at its sides with a top panel **18** and a

relatively wider bottom panel **19** was centered horizontally on and suitably secured to pedestal **16**. The base **15**, pedestal **16** and frame **17** could be formed of any suitable material. A pair of tubular uprights **20** rose from opposite ends **21** of the frame **17** with lower ends fixed in suitable keepers **22** on the ends **21**. A conventional fluorescent lamp fixture **23** connected the upper ends of the uprights **20** with the usual fluorescent light tube **24** extending along the bottom of the fixture.

The water tank **13** was of flat rectangular shape and any suitable transparent material and was seated flat on the top panel **18** of the frame **17** between the uprights **20**, the tank extending longitudinally of the frame **17**. The water tank **13** was of the same width as the top panel **18** of the frame **17**. The plant box **14** was of elongated rectangular form and seated in the frame **17** on the bottom panel **19** to extend longitudinally. The plant box **14** was wider than the top panel **18** and the water tank **13** to project beyond the sides of the top panel and tank.

A downwardly flaring shade **25** was provided for suspension from the rim of the water tank **13**. The shade **26** comprised a pair of downwardly diverging side frames **26** open opposite the sides of the water tank **13** solely to frame the tank at the sides and render the contents visible from the sides of the aquarium. Internal hooks **27** on the side frames **26** fit over the rim of the water tank **13** and suspended the shade **25** from the rim. The upper portion of the shade **25** circumscribed the lamp fixture **23** and light tube **24** to conceal it and the lower portion of the shade similarly concealed the frame **17** and plant box **14**. Electric wiring **28** extended into the pedestal **16** and through one tubular upright **20** and was connected in the conventional manner, not shown, to the fluorescent light tube **24** for energizing the it from a house circuit to which the wiring could be connected in the usual manner. A suitable switch **29** was provided in the base **15** and in the wiring **28** for closing circuit to the light tube **24**.

In using the modified embodiment of the aquarium, the shade **25** framed the water tank **13** at the sides for ornamentation, and plants grown in the plant box **14**

could be trained to project out of the side frames **25** along the bottom of the water tank **13** for further ornamentation. With the fluorescent light tube lighted, water in the water tank **13** was illuminated to further enhance the ornamental appearance in the aquarium and provide illumination in a room or the like. The second modified embodiment of the aquarium, shown in Figures 7 to 11, was a hanging wall aquarium, the basic element of which was a water tank support **30** that comprised a pair of upright elongated end panels **31** connected together adjacent at the lower ends by a horizontal bottom panel **32** of the same width. A rear, upper horizontal bar **33** also connected the end panels **31** together. A cord, or the like, **34** was connected as at **35** to the rear upper corners of the end panels **31** for hanging the support **30** on a wall, not shown.

The water tank **36** in this instance was also of rectangular flat form and any suitable transparent material and was seated on the bottom panel **32** between the end panels **31** to extend longitudinally of the support **30**. A rectangular front frame **37** for the water tank **36**, higher and wider than the support **33**, was hinged at one side and on the rear face to one end panel **31**, as at **38**, to be swung open and closed against the front of the support. The frame **37**, when closed, concealed the support **30** from view from the front and overlapped the front edges of the tank **36** to frame it. A suitable spring catch **38'** yieldingly retained the frame **37** closed. A rearward extending horizontal shelf **39** was suitably fixed on the bottom edge of the frame **37** and a horizontal row of apertures was provided in the frame **37** directly below the bottom panel **32**.

An elongated rectangular plant box **41** of substantially the same width as the shelf **39** and the end panels **31** was removably seated on the shelf below the bottom panel **32** and the row of apertures **40**. A net panel **42** was suitably hung, as at **43**, on the bar **23** for draping behind the water tank **36**. Apertures **44** in the frame **37** above the water tank **35** were provided for training aquatic plants, growing in water in the tank outwardly through the frame. In the use of the second modified embodiment of the aquarium, the water tank **36**, as in the other embodiments, was framed by the frame **37**. The net panel **42** behind the water tank **36**, when

viewed through water in the tank, produced an unusual ornamental effect. Plants, not shown, grew in the plant box **41** and trained out of the apertures **40** together with aquatic plants, not shown, grew in the water **45** and trained out of the openings **44**, lent further ornamentation to the aquarium at the top and bottom. By opening the frame **37**, access could be had to the water tank **36** for removing and/or filling it and the plant box **41** could be swung outwardly away from the support **30** for access as might be required.

[Figure 231, Animated Display Aquariums, Number 2751880] Our last aquarium patent is both eccentric and extravagant. This is the animated display aquarium patented in 1956 by Adam M. Markowski of Philadelphia (Figure 231-2751880). The inventor even suggested using it as the base for a Christmas tree (A in the diagram). The device consisted of an oval waterway for the fish, submerged in a miniature terrain similar to that used by model railroad enthusiasts, and complete with miniature plants (they could be real or artificial), a lighted tree and a bridge. A motor-driven propeller with a cage around it protect the fish (B in the diagram) produced a current within the waterway that provide both motion and aeration. A decorative float that moved with the flow of water could be placed in the waterway, as well as a horizontal water wheel (one with fish figures that fly outward is shown in C and D). However, the fish would have been difficult to have been seen in this contraption and, in any case, would have been unnoticed among all of the other action going on around them.

Figure 1 represents a perspective view of a display device embodying the invention; Figure 2 represents a plan view; Figure 3 represents a sectional view taken along the lines **3 - 3** of Figure 2; Figure 4 represents an enlarged sectional view taken along the lines **4 - 4** of Figure 2; Figure 5 represents an enlarged sectional view taken along the lines **5 - 5** of Figure 2; Figure 6 represents an enlarged sectional view of a miniature representation of a path, taken along the lines **6 - 6** of Figure 2; Figure 7 represents an enlarged fragmentary view of a portion of the channel, showing one form of water wheel and guard assem-

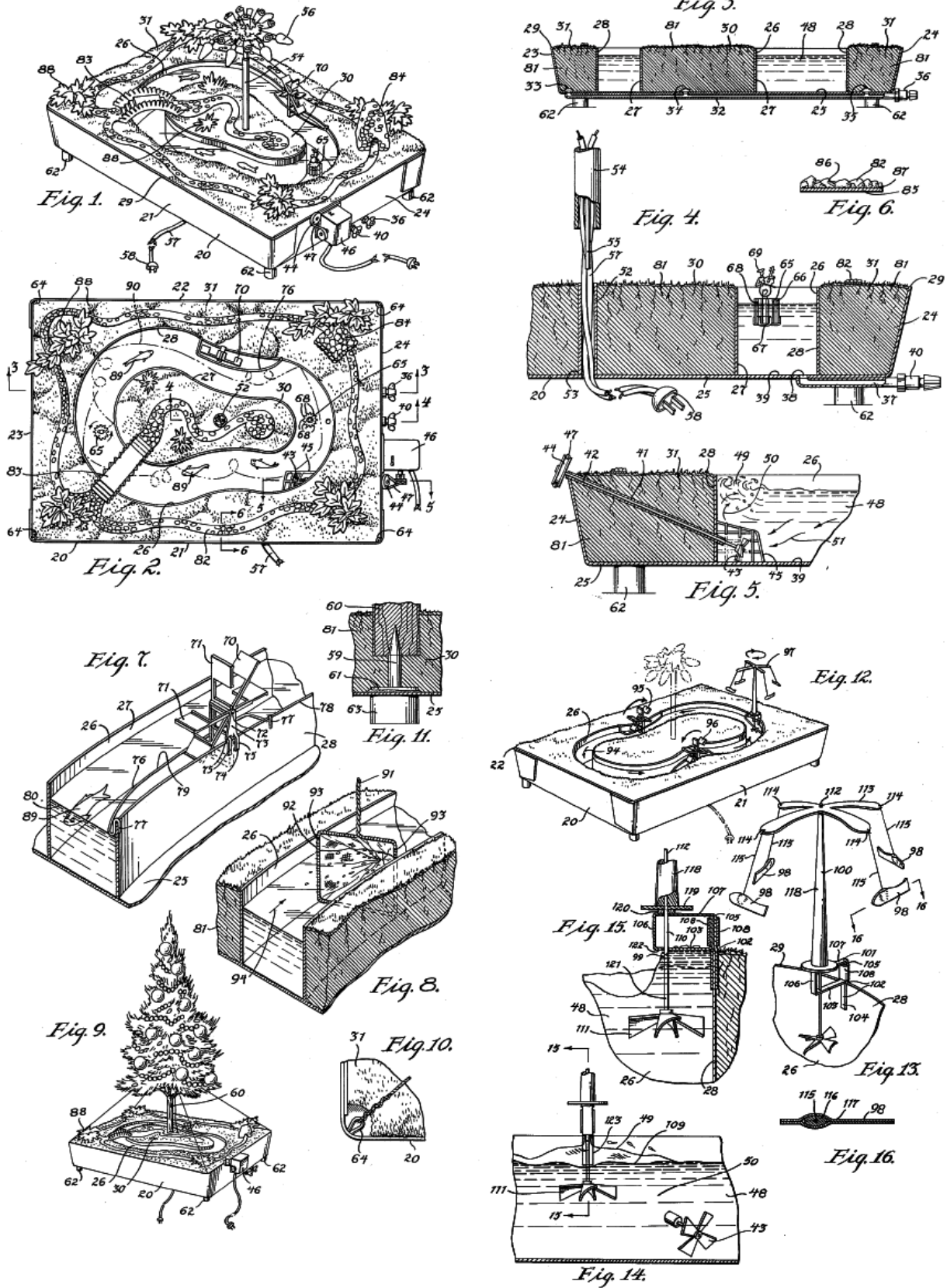

Figure 231: Adam M. Markowski's animated display and built-in aquarium, 1956.

bly, and embodying the invention; Figure 8 represents an enlarged perspective view of a channel portion, showing a method of cleaning the water contained therein, which method is rendered possible by the invention; Figure 9 represents a perspective view showing a modification of the display device wherein a severed tree is supported thereby and plantings combined therewith in a unitary display; Figure 10 represents an enlarged fragmentary view of an anchor means on said display device for securing a severed tree therewith; Figure 11 represents an enlarged, fragmentary sectional view illustrating a trunk-mounting means which may be utilized in the assembly illustrated in Figure 9; Figure 12 represents a perspective view of a display device of a modified construction and embodying the invention; Figure 13 represents an enlarged perspective view of the bracket, post, horizontal water wheel and display mechanism assembly detail of a portion of the modification of the invention illustrated in Figure 12; Figure 14 represents an enlarged, fragmentary elevational view of the assembly illustrated in Figure 13 and showing it in relation to the propeller; Figure 15 represents a further enlarged, vertical sectional view, taken along the lines 15 - 15 of Figure 14 and Figure 16 represents an enlarged sectional view taken along the lines 16 - 16 in Figure 13.



CONCLUSION

Although we poke a great deal of fun at the Rube Goldberg designs, some were ahead of their day and others showed considerable imagination. In 1785 William Cowper observed, "Thus first necessity invented stools, convenience next suggested elbow-chairs, and luxury the accomplished sofa at last."

Thus has it been in the history of aquarium inventions.

It should be noted that there is a subtle difference between invention and innovation. Innovation is the process of converting knowledge and ideas into better ways of doing things. An essential element for innovation is its application in a commercially successful way. Invention, on the other hand, is about creating something completely new. There are several differences between innovations and inventions. An invention can lead to an innovation, but many inventions are often created and then placed on a shelf. In fact, most of the patents discussed in this book never saw the light of day. On the other hand, many aquarium innovations have been introduced but never patented. In spite of these differences, aquarists owe a great debt to these imaginative pioneers, be they inventors or innovators.

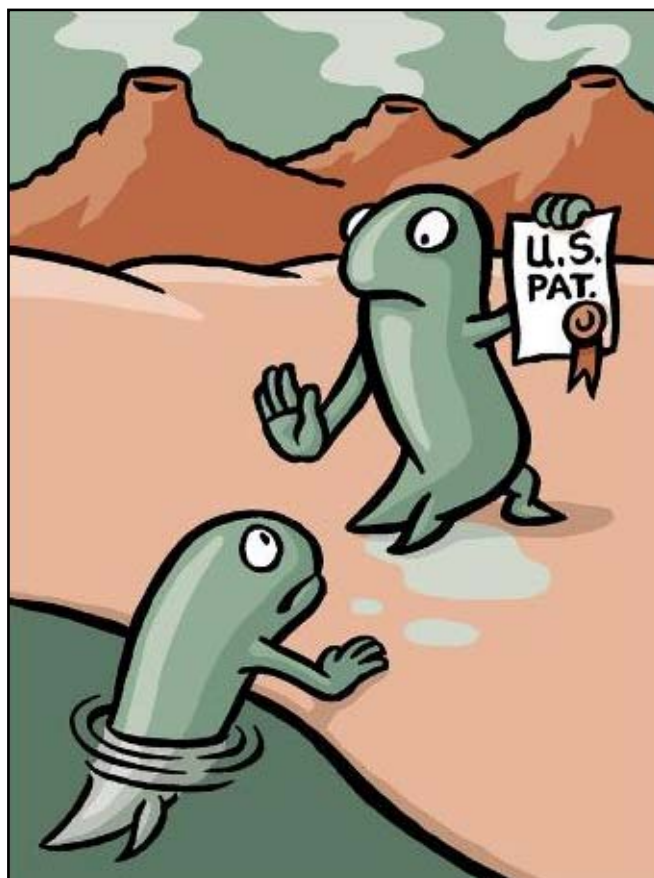

INDEX

The entries in this Index are in a three-part code: Page number for text (**bold-faced in red**), Figure number, dash and then Patent Number, i.e., **47(166-2732341)** signifies that the text starts on page 47, the Figure number is 166, and the Patent number is 2732341.

AERATION

4(5-31657),**4**(7-46801),**6**(10-143456),**12**(28-597249),**14**(35-894056),**16**(43-950999),**16**(44-976242),**16**(45-1055082),**58**(62-1574783),**81**(95-2008369),**82**(96-1939583),**82**(97-1945962),**84**(98-2008363),**85**(99-D96540),**85**(100-2028913),**87**(101-1956524),**120**(164-2172799),**122**(165-2253516),**123**(166-2732341),**133**(177-2491853),**134**(178-2772867),**136**(179-2824728),**138**(180-2847973)

AQUARIUM, BIRDCAGE

11(8-164074),**11**(9-192595),**17**(15-296853),**62**(66-D53157)

AQUARIUM, BRIDGE

62(67-1576462),**97**(111-1943417),**98**(112-2059927)

AQUARIUM, COMBINATION

42(38-692832),**53**(57-1169449),**54**(58-1263391),**69**(79-D64852),**99**(113-2000451),**99**(114-D109478)

AQUARIUM, CONSTRUCTION

6(2-21719),**23**(22-534052),**56**(59-1322322),**57**(60-1432827),**58**(61-1571196),**77**(90-1852597),**78**(91-2081023),**92**(92-1986018),**79**(93-2016439),**176**(204-2713847),**178**(205-2787981),**179**(206-2792811)

AQUARIUM, FLAT-SIDED BOWL

48(46-D49292),**48**(47-D49480),**66**(71-D77018),**101**(115-D97041),**101**(116-D102550)

AQUARIUM, FOUNTAIN

13(11-147849),**14**(12-188941),**42**(40-D37181),**49**(51-919157),**67**(73-D53718),**67**(74-D53719),**68**(75-1649683),**101**(125-1965323)

AQUARIUM, FRAMED

51(52-D43062)

AQUARIUM, GLOBE OR BOWL

18(16-233435),**19**(17-256240),**42**(39-715571),**49**(48-925861),**49**(49-D51663),**50**(50-D51433),**66**(72-1674046),**101**(117-D80204),**101**(118-D85253),**101**(119-D89307),**101**(120-D98762),**119**(162-D98718),**186**(215-2512678),**187**(216-D160125),**187**(217-2646021)

AQUARIUM, HANGING

11(19-295218),**12**(20-415506),**64**(68-1641496),**119**(163-D96947)

AQUARIUM, LAMP

71(84-1297254),**72**(85-1333454),**73**(86-1449772),**73**(87-D78595),**103**(126-1723272),**104**(127-1762634),**105**(128-1871742),**105**(129-D108779),**106**(130-D110271)

AQUARIUM, NOVEL

19(18-225646),**52**(55-1127976),**52**(56-D48946),**65**(69-D76252),**65**(70-1620006),**74**(88-1643527),**74**(89-1634305),**111**(141-1858181),**112**(142-D82230),**113**(143-D83137),**113**(144-1860698),**114**(145-1908939),**116**(147-D83044),**116**(148-D84002),**116**(149-D85201),**116**(150-D86002),**117**(151-D90032),**117**(152-D90041),**117**(153-D90646),**117**(154-D90647),**117**(155-D92416),**117**(156-D92776),**117**(157-D93033),**117**(158-D94058),**117**(159-D94248),**117**(160-D95727),**117**(161-D97759),**125**(167-D125884),**125**(168-D136064),**125**(169-D136624),**125**(173-2272582),**138**(180-2847973),**190**(221-2503945),**190**(222-D152456),**191**(223-2494937),**192**(224-2808024),**194**(225-D168582),**194**(226-D169866),**195**(227-D167243),**195**(228-2844912),**197**(229-2720724),**198**(230-2595085)

AQUARIUM, PUBLIC

14(13-165639),**16**(14-324508)

AQUARIUM, RECTANGULAR

9(6-D1988),**51**(53-D48108),**70**(83-1481435),**93**(107-2002380),**101**(121-D85181),**101**(122-D86325),**101**(123-D86914),**101**(124-D93365),**189**(218-D158074)

AQUARIUM, STAND

52(56-D48946),**69**(76-D55751),**69**(77-D55753),**69**(78-D55754),**69**(80-D74902),**70**(81-D75081),**70**(82-D76204),**110**(135-D78013),**110**(136-D78682),**110**(137-D80395),**110**(138-D80865),**111**(139-D85413),**111**(140-D100200)

AQUARIUM, TABLE

116(146-2133740),**125**(170-D148608),**125**(171-D149043),**125**(172-D149527),**189**(219-D159661)

AQUARIUM, WALL

8(4-31040),**23**(21-475404),**51**(54-D41977),**106**(131-1777944),**107**(132-1974068),**109**(133-1991683),**109**(134-2144551)

BREEDING TRAP

33(30-680838),**60**(63-1444367),**22**(64-1552063),**182**(208-D171472)

CHEMISTRY

35(32-634626)

CLEANING

13(10-143456),**24**(23-460809),**26**(24-460810),**28**(25-475082),**29**(26-546882),**34**(31-649494),**36**(33-880783),**37**(34-867112),**133**(177-2491853),**140**(181-2672987)

FEEDING

40(36-742415),**41**(37-848101),**88**(102-1976962),**89**(103-1989298),**160**(193-2711714),**161**(194-2718211),**161**(195-2727489),**162**(196-2754800),**162**(197-2761422),**163**(198-2725852),**165**(199-2772659),**167**(200-2785831),**170**(201-2808808),**172**(202-2847066),**174**(203-2858799)

FILTRATION

31(28-597249),**45**(43-950999),**48**(45-1055082),**120**(164-2172799),**122**(165-2253516),**123**(166-2732341),**133**(177-2491853),**143**(182-2595965),**144**(183-2614529),**146**(184-2636473),**147**(185-2674574),**149**(186-2676921),**150**(187-2730496),**152**(188-2744065),**154**(189-2748075),**157**(190-2786026)

HEATING

31(28-597249),**82**(96-1939583),**90**(104-1981251),**93**(107-2002380),**158**(191-2566990),**159**(192-2805313)

HEATING, LAMP

91(105-1803571),**92**(106-2016123)

LIGHTING (see also AQUARIUM, LAMP)

49(51-919157),**54**(58-1263391),**68**(75-1649683),**75**(89-1634305),**92**(106-2016123),**112**(142-D82230),**113**(143-D83137),**113**(144-1860698),**132**(176-2293612),**132**(180-2847973),**185**(214-2776642)

MISCELLANEOUS

3(1-D163377),**7**(3-22019),**80**(94-1838215),**94**(109-1764356),**95**(110-2117616),**132**(175-D117704),**132**(176-2293612),**189**(220-D172706),**200**(231-2751880)

PLANTS

13(11-147849),**14**(12-188941),**26**(24-460810),**29**(27-546883),**42**(38-692832),**42**(39-715571),**53**(57-1169449),**54**(58-1263391),**99**(113-2000451),**99**(114-D109478),**110**(135-D78013),**128**(174-2306027),**197**(230-2595085)

REFRIGERATION

181(207-2594474)

TANK COVER

185(212-D176905),**185**(213-D176906),**185**(214-2776642)

TRANSPORTATION, FISH

32(29-613528),**43**(41-710325),**44**(42-846864),**61**(65-1616125),**94**(108-1991149),**182**(209-2476704),**183**(210-2783736),**184**(211-2763239)



**The First Heated Aquarium? Invented by
Hero of Alexandria, 100 B.C.**

A HISTORY OF AQUARIUM INVENTIONS

The First 100 Years

By Albert J. Klee

Combination
Aquarium, Elevator
and Fountain: 1880

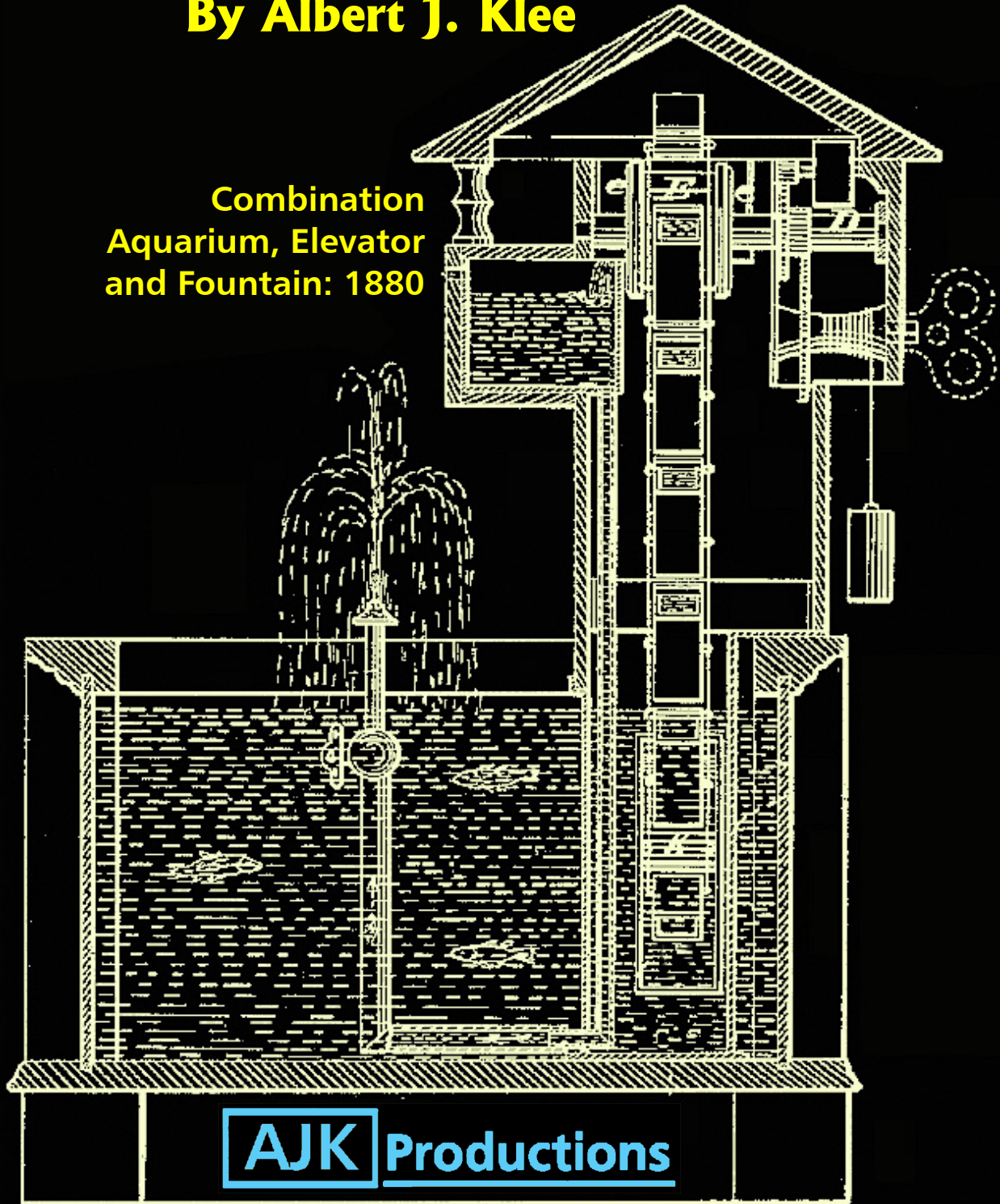

AJK Productions